

Ultimate2: QRSS Labs Multi-mode QRSS Beacon Kit

PCB revision 2

1. Introduction

Thank you for purchasing my second generation “Ultimate2” Multi-mode QRSS beacon kit. This kit is capable of automated transmission of a range of weak signal modes that are capable of worldwide HF propagation using a fraction of a watt of RF output power. The DDS module permits accurate, stable operation anywhere on HF whilst plug-in low-pass-filter modules allow easy band changing.

Recommended approach to building the kit: This is a simple design but there are a large number of features which provide a great deal of flexibility. **Read this WHOLE manual and understand it!** Follow the construction section to build the kit. Use a receiver connected to your PC, with a slow-signal decoding program such as Argo, to monitor your signal, experiment and understand the various features before connecting an antenna! **Good performance depends on proper set up:, see the calibration section.**

Please read the DDS module stability section 7! Do not miss this section, or your output signal may be unstable and look horrible!

This assembly manual is to be read in conjunction with the operation manual!

The kit supports the following modes:

- QRSS mode (plain on/off keyed slow CW)
- FSK/CW mode (frequency shift keyed slow CW)
- DFCW mode (dual frequency CW, dit's and dah's on different frequencies)
- WSPR mode (Weak Signal Propagation Reporter)
- Slow-Hellschreiber (frequency shifted slow Hellschreiber)
- Hellshreiber (full-speed standard Hellschreiber, and half-speed Hellshreiber)
- CW (plain CW) and fast FSK mode
- Customisable FSK patterns

Other features:

- DDS-controlled output frequency (through-pin DDS module, no SMD soldering required)
- Plug-in low pass filter boards (available for 10 HF and 2 LF bands)
- 24-character LCD + two-button user interface
- User-programmable (callsign, message, speed, FSK, mode, etc.), settings stored in EEPROM
- GPS interface, for locking the frequency, timing and location information
- On-chip generation of WSPR encoded message (no PC required)
- WSPR maidenhead locator can be generated from GPS-derived latitude/longitude
- Selectable “frame” size, for stacked QRSS reception
- Plain CW callsign identifier at selectable interval
- Produces approximately 150mW RF output on 30m (lower output on higher frequency bands)
- Higher output power by fitting additional PA transistors and/or higher PA supply voltage

The transmitter is designed to be powered with 5V DC, which could come from a mobile phone charger, wall wart, or even four 1.5V batteries connected in series with a suitable low dropout regulator. Do not use more than 6V: this may kill the microcontroller; the LCD may not work properly with more than 5V. Best results will be obtained with a well-regulated and well-smoothed 5V supply.

2. Design

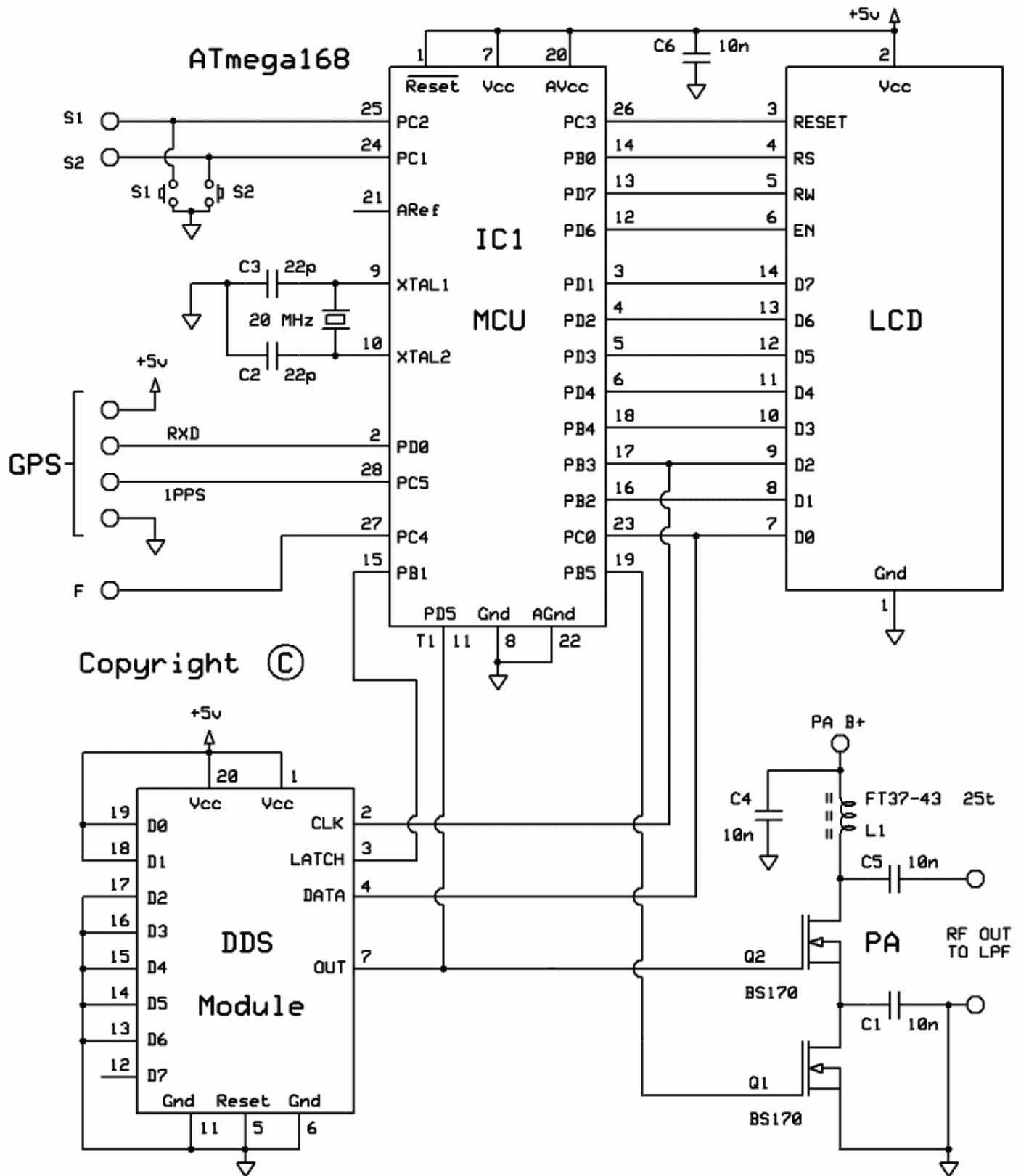

Ultimate-2 Multimode QRSS Kit by Hans Summers G0UPL Jan 2013

The ATmega168 AVR microcontroller (IC1) is pre-programmed with firmware to control the LCD, buttons, and GPS interface. The AD9850 Direct Digital Synthesis (DDS) module includes its own on-board 125MHz crystal reference oscillator, and reconstruction filter components ready-mounted. On/off keying is provided by the BS170 transistor Q1, and power amplification by another BS170 transistor, Q2, producing over over 150mW from a 5V supply on 30m. Finally standard 7-element low pass filter plug-in modules remove harmonics of the transmission frequency.

3. Parts List

3.1 Resistors

R1, 2	Not used in PCB revision 2
R3	No resistor – space is provided on the PCB only for possible future expansion
R4	No resistor – space is provided on the PCB only for possible future expansion

3.2 Capacitors

C2, 3	22pF (ceramic, marking 22)
C1, 4, 5, 6	10nF (ceramic, marking 103)

3.3 Inductors

L1	25 turns, FT37-43 core (black)
----	--------------------------------

3.4 Semiconductors

Q1, 2, 3, 4	BS170 (note: only two are provided in the kit. The other two may be added for more power).
IC1	Pre-programmed ATmega168 microcontroller
DDS	AD9850 DDS module, including 125MHz reference oscillator and reconstruction filter

3.5 Miscellaneous

Push buttons S1 and S2
1 row, 24 character LCD
Printed circuit board
Wire for winding toroids
Socket for IC1
20MHz quartz crystal
Two 10-pin female header sockets
Two 4-pin female header sockets

4. Construction

4.1 General construction tips

The kit comes as a main board, with pre-assembled DDS module, and a plug-in low-pass-filter module for the desired band. **Since the low-pass filter module is a separate kit in its own right, please refer to the separate instructions for constructing that kit.**

Parts placement is defined by the printed legend on the PCB, so please observe it carefully, paying particular attention to the correct orientation of the semiconductors.

The PCB is quite small and the parts are close together. You are recommended to use a low wattage iron with a fine tip, and fine solder e.g. 1mm diameter or less. Take care not to overheat the PCB and risk damaging it. A well-lit area and magnifying glass can assist. Be careful not to bridge solder across closely-packed connections. Some of the joints are very close to each other. I recommend checking with a DVM to make sure no solder bridges have been inadvertently created.

Note that components R1, R2, R3 and R4 are not required or supplied in the kit. Q3 and Q4 are not supplied, additional BS170 transistors may be installed here to increase the output power (see below). IC1 (the microcontroller) has an IC socket, in case in future you wish to change the microcontroller e.g. for a firmware upgrade for new features, etc., or in case you wish to program it yourself. Sockets are provided for the DDS module and the low-pass-filter module.

4.2 LCD and button mounting options

Now before going any further, you need to consider how you want to mount the LCD and buttons. There are two push-buttons in this kit, and they must be mounted on the BOTTOM side of the PCB, so that they do not get in the way of the plug-in modules on the top side. If I was to make space for the buttons on the top side of the PCB, the PCB would have become somewhat larger. A larger PCB costs more to make and that would increase the cost of the kit. I did everything possible to minimise the kit cost! So you have to put up with this potential inconvenience. Please read about the three possible LCD mounting options and decide now, which one you want to use.

Method 1: LCD and buttons mounted off-board

This method removes the requirement to solder the fine-pitch LCD pins. It is also convenient for those of you who wish to install the LCD and kit in an enclosure, for example to mount the LCD in a front panel.

In this case, the pins of the LCD should be bent alternately in different directions. Short lengths of wire can be used to connect the LCD to the PCB, using the row of holes adjacent to the fine-pitched LCD holes. This row of holes are spaced at 0.1-inch pitch so are much easier to solder than the 0.05-inch pitch holes if you were to solder the LCD directly to the PCB. The photograph below shows the LCD pins bent different ways and starting to solder some wires to them. Of course, take care to solder the right wires to the right holes.

You may also wish to consider using your own push-buttons installed in a front panel for example. In that case please refer to section 5.3 below, on how to connect external push-buttons.

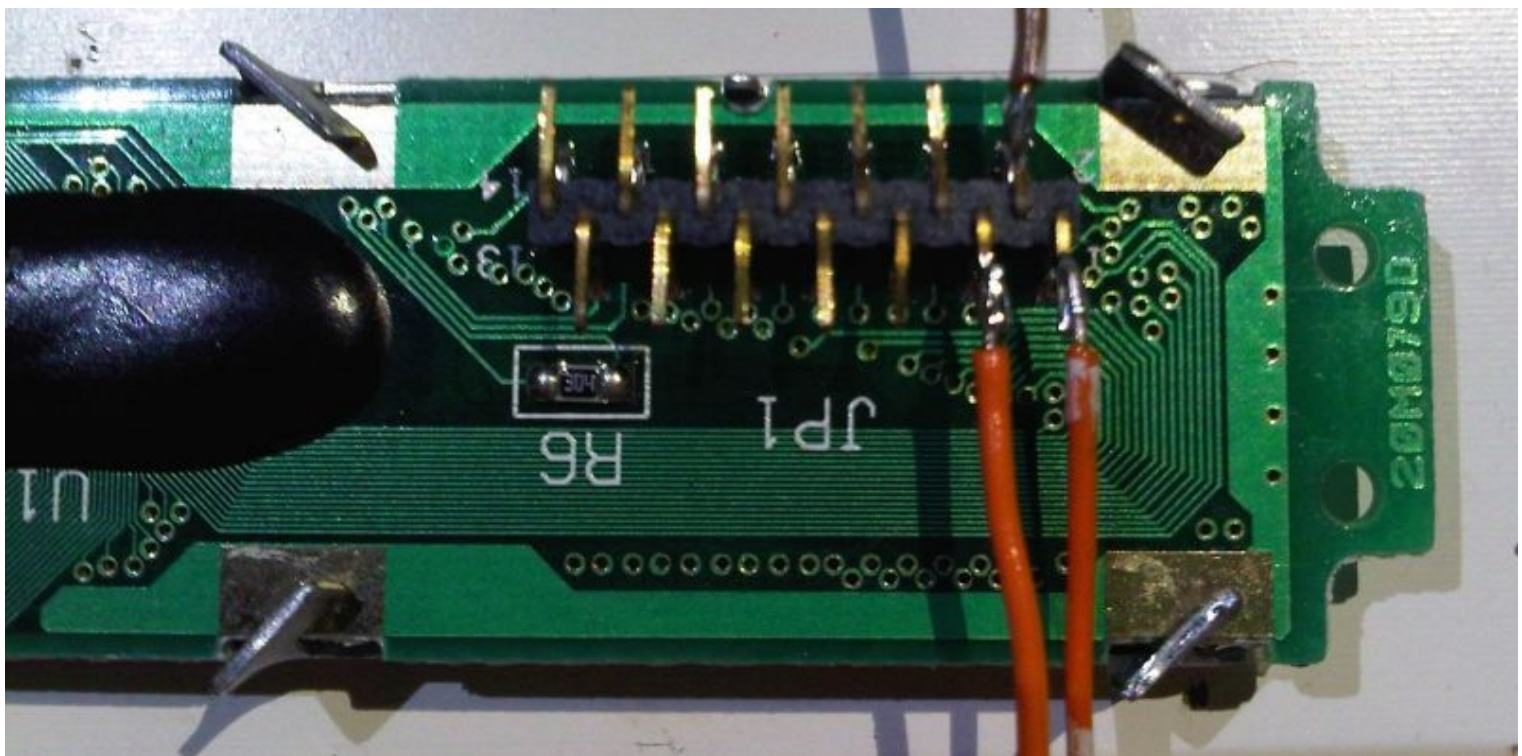

Method 2: LCD mounted directly to the reverse of the board

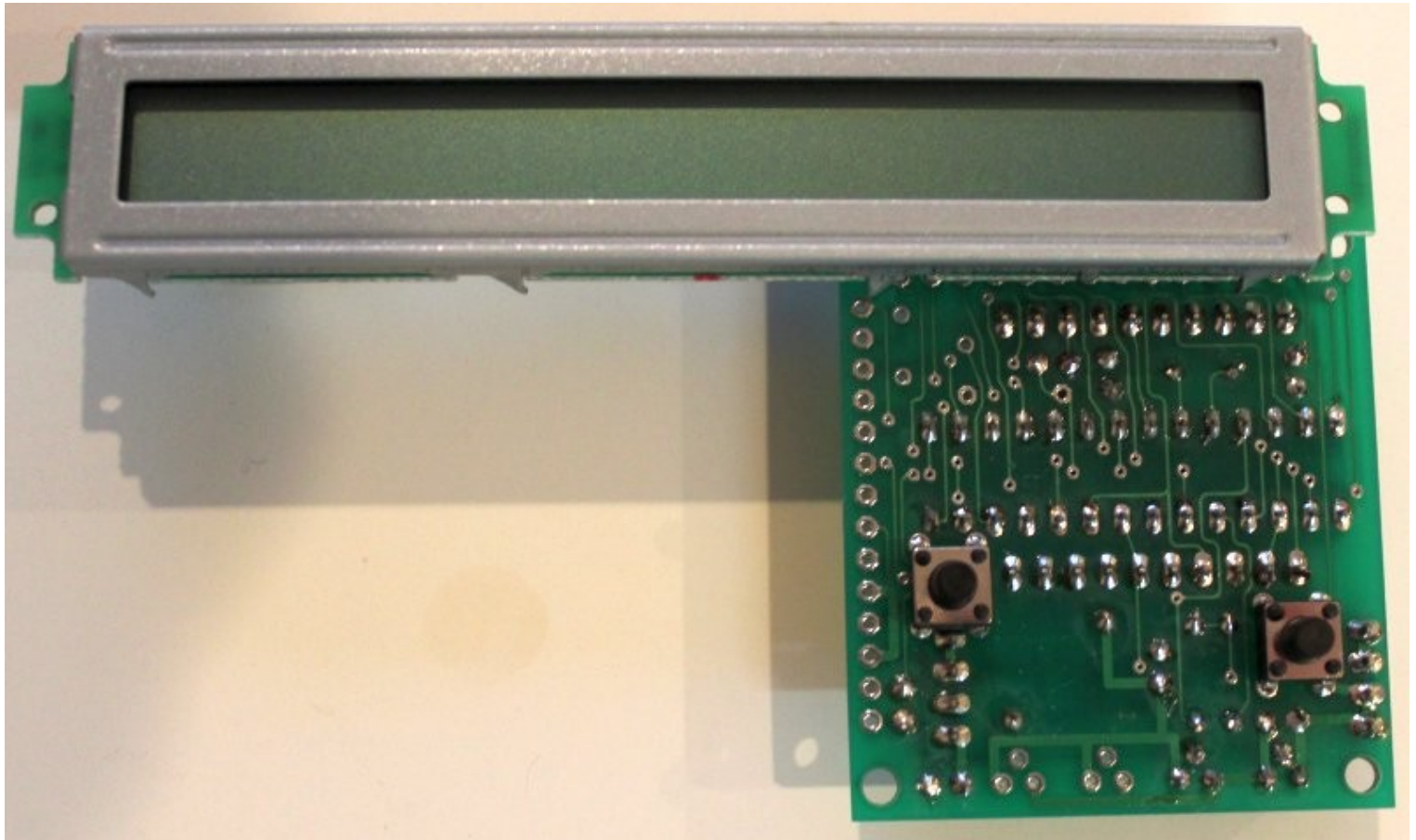

This method is probably the easiest and most direct. The LCD is just soldered in position on the reverse of the board. Make the solder joints on the component side of the PCB. The two buttons are in this case directly accessible. The disadvantage is that the board components are now upside-down! In this configuration you might want to mount some 40mm long bolts in the main PCB corner holes, in order to lift the PCB up, as if on pillars, so that it is not resting on the components underneath.

Note also that in this configuration, you would need to set the “Inv. Btn.” parameter to ON, since the default configuration will have the left and right buttons reversed in this case.

Method 3: LCD at right-angles

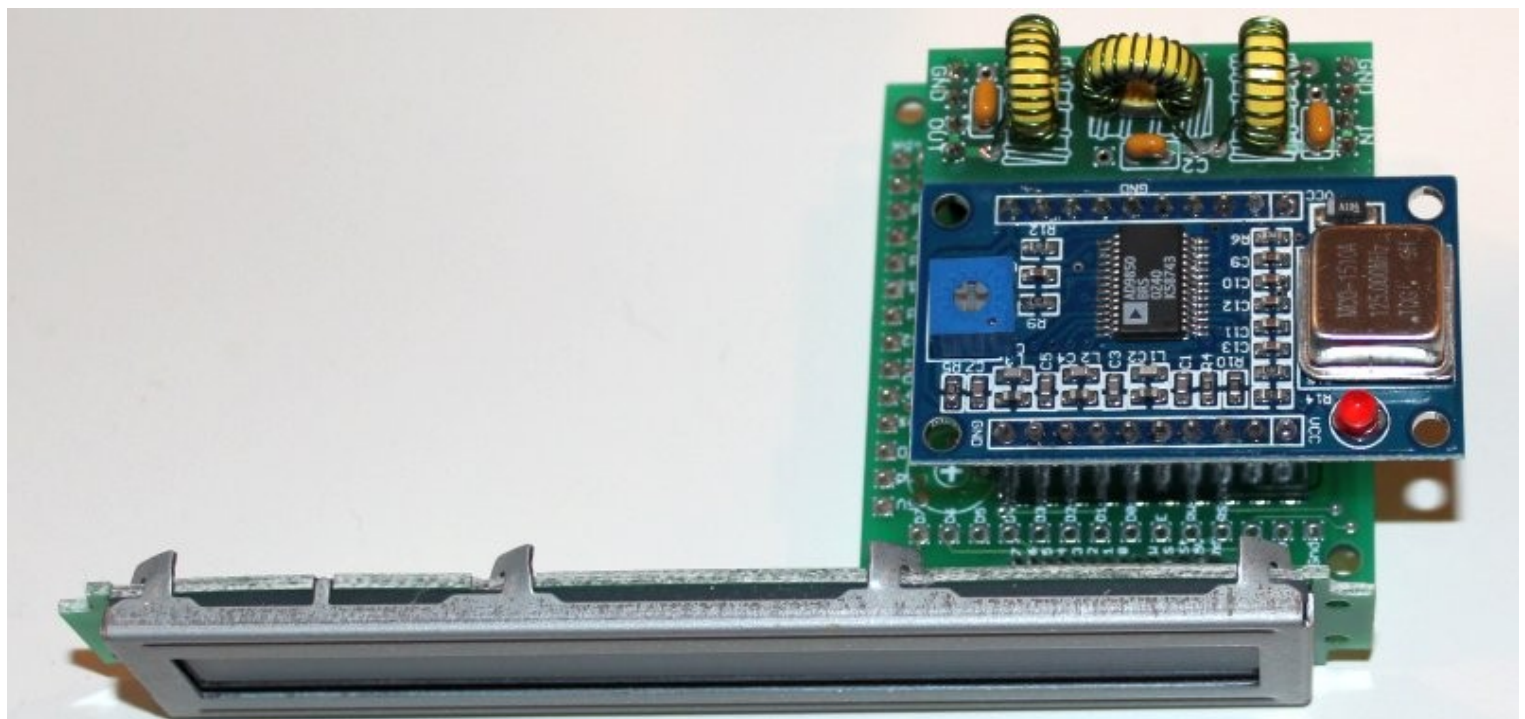

This method is really my favourite method, because it allows the LCD to face the front, convenient for mounting in a front panel.

The buttons are still underneath the PCB – however it is not too difficult to set up the kit by holding it in one hand, with the LCD facing towards you, and pressing the buttons underneath. My recommendation is still to fit the buttons (or your own buttons) off-board on a length of cable, and mount them in the front panel.

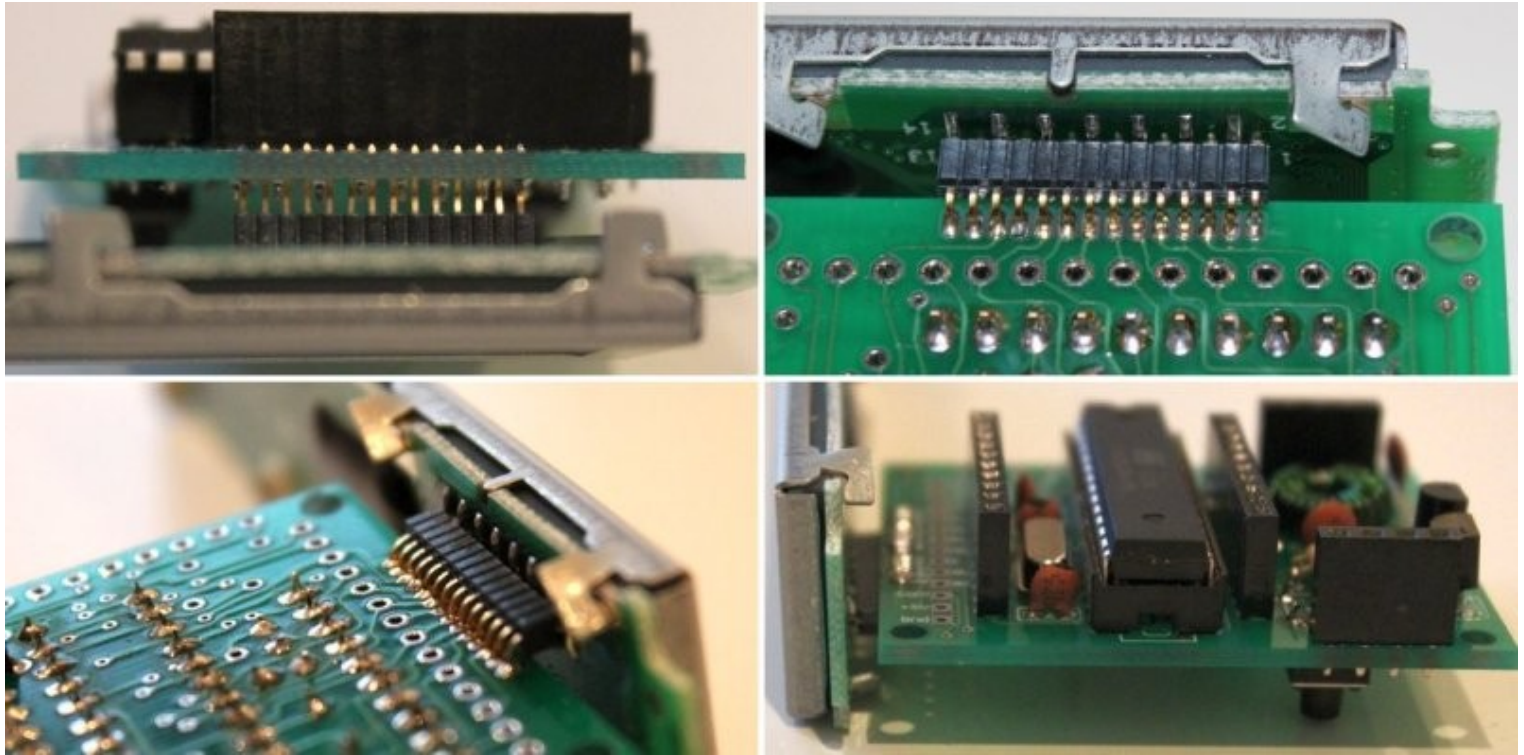

Step 1: Insert the LCD from the bottom of the board. I suggest soldering just the two end pins only, and solder from the top side of the board: this allows un-soldering easily in the event tat However, leave a gap of a few mm, as seen in the top left photo above. That is very important! It allows space for bending the pins at right-angles.

Step 2: Carefully put force on the LCD to bend the pins at right-angles. This has to be done very gently, to not rip off the connector pins from the LCD, which is delicate.

Step 3: Solder the remaining LCD pins, from the top (component side) of the board. The end result should be as shown in the pictures above.

Note 1: this kit is NOT compatible with the common Hitachi HD44780-based LCD display modules.

Note 2: the LCD is quite DELICATE! If you use bolts fix the LCD to a front panel, ensure suitable spacers or washers are used so that stress is not put on the LCD, or it may crack.

4.3 Construction steps

Please refer to the parts placement diagram below.

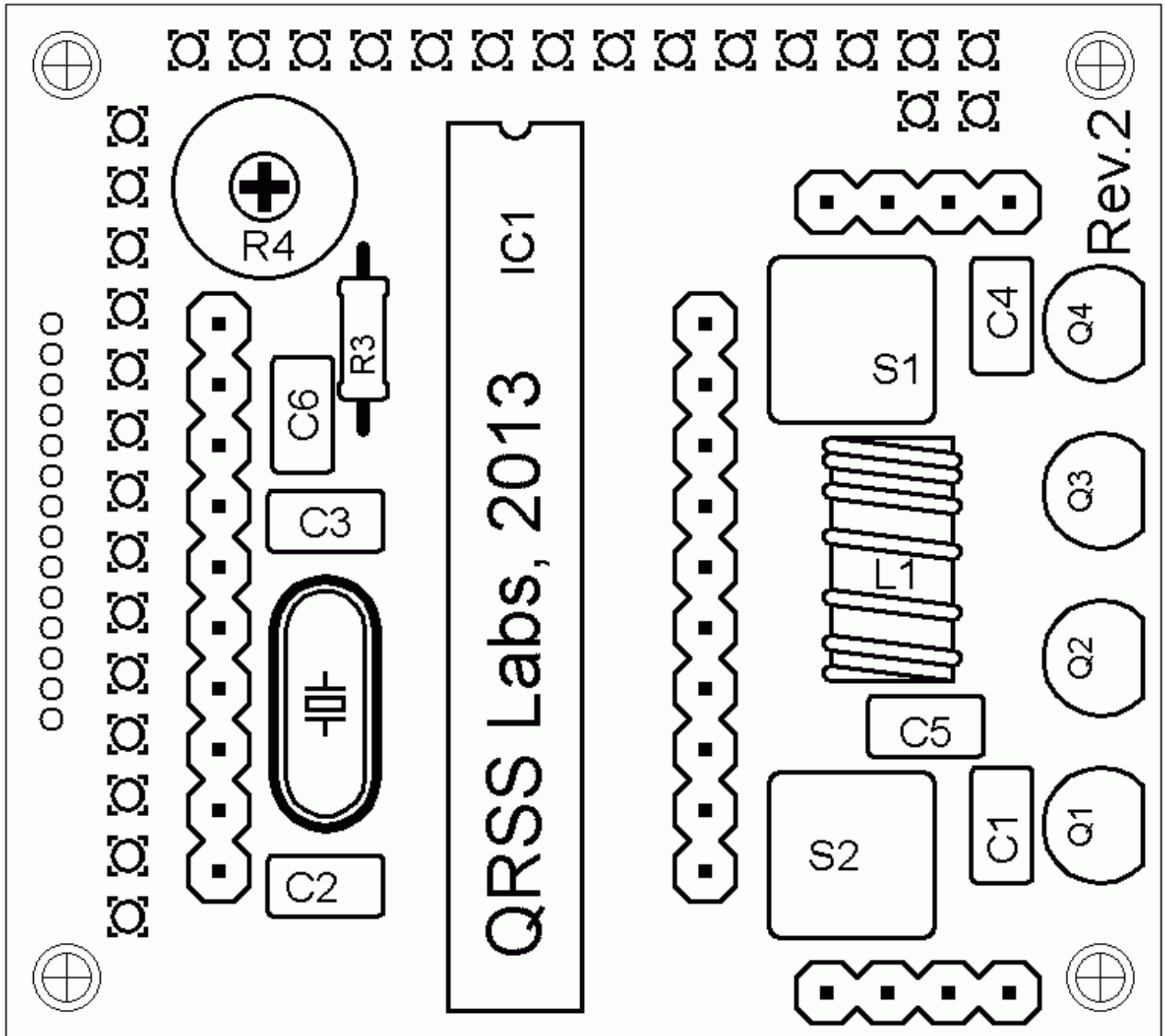

Pay special attention to the orientation of the semiconductors. For IC1, the dimple in the PCB silkscreen must be aligned with the dimple at the top of the IC socket and the IC.

The order of construction is not important but a good principle to follow is to install the smaller components first, so that the larger ones do not prevent easy access. One suggested order of construction is:

- 1) Install the socket for IC1
- 2) Install all capacitors and the quartz crystal
- 3) Install switches S1 and S2 on the **lower** side of the board, if not using off-board switches
- 4) Wind and install the toroid – The toroid can be mounted horizontally or vertically. I prefer the horizontal method as there is enough space for it, and it keeps the toroid away from the LPF module which is plugged in above. .

- 5) Install the sockets for the DDS module and the low-pass-filter board. Some care needs to be taken with the alignment, to ensure that there is a good fit when the plug-in boards are added. One method is to build the LPF kit board first, and use the DDS and LPF boards plugged into the sockets, then solder the pins, to ensure correct alignment.
- 6) Install the LCD – first consider how you want to box the kit (see LCD mounting options below).

Installation of the LCD requires particular care, because the pin-spacing of the LCD is only 0.05-inches. Use of a fine tip soldering iron is advised, and check carefully for shorts between pins, using a magnifying lens and Digital Voltmeter (DVM). Ensure correct orientation of the LCD as per the photographs in the LCD mounting options section 4.2, above.

When winding the toroid, remember that each time the wire goes through the centre of the toroid counts as one turn. 35cm of wire should be enough for 25 turns. Trim the ends of the wire, scrape the enamel off and tin them with solder. As an alternative to scraping the enamel off, the wire ends may be held in a hot blob of solder on the iron tip for a few seconds, and the enamel will bubble away. Check continuity on the board with a DVM.

4.4 Module assembly

First the microcontroller IC1 should be inserted in its socket.

Next, plug together the three modules as shown in the photograph on the right. Ensure that the DDS module is inserted the correct way round. The Low Pass Filter kit module should be plugged in with the “Out” legend aligned next to the RF Output connector of the main PCB.

4.5 Notes concerning the DDS module

- a) You will notice that the DDS module has a square, blue plastic adjustment preset potentiometer. This adjusts the threshold for the DDS chip comparator that turns its 1V p-p sine wave into a square wave to drive the microcontroller. Adjusting it will change the duty cycle of the DDS square wave. You should not need to adjust this potentiometer, as I have already adjusted it individually, when I tested every DDS module before putting it in a kit. However, some builders have noted that the potentiometer needs to be adjusted slightly for best output waveform on 10m (28MHz). The adjustments needed are extremely slight, the potentiometer setting is very sensitive.
- b) The module uses the AD9850 DDS chip. The module is officially rated for output from DC to 40MHz. You may want to test it at higher frequencies than that. In theory the chip could output up to 62.5MHz (half the 125MHz reference clock frequency), but the output amplitude and spectral purity will deteriorate.
- c) It is normal for the 125MHz reference oscillator (metal can on the right) to get hot in operation.

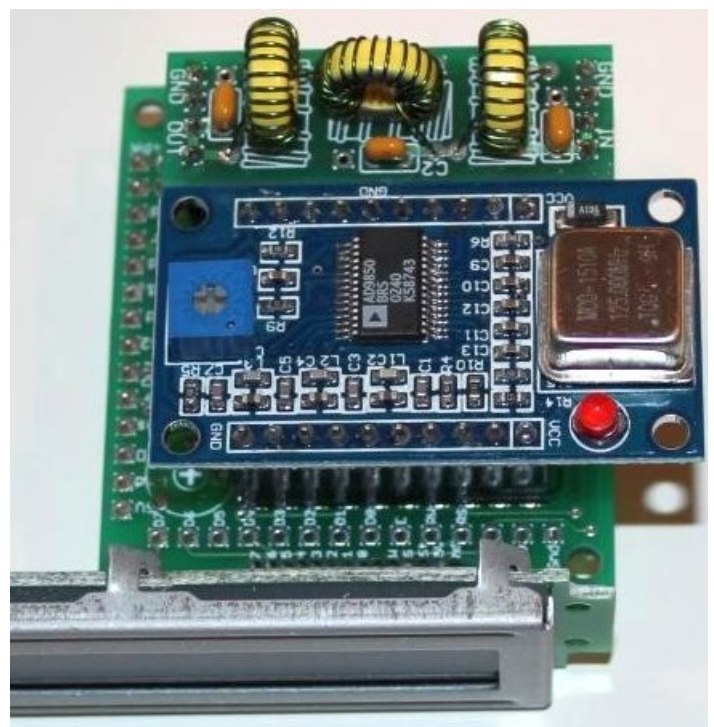

5. Hardware Options

5.1 Explanation of connections

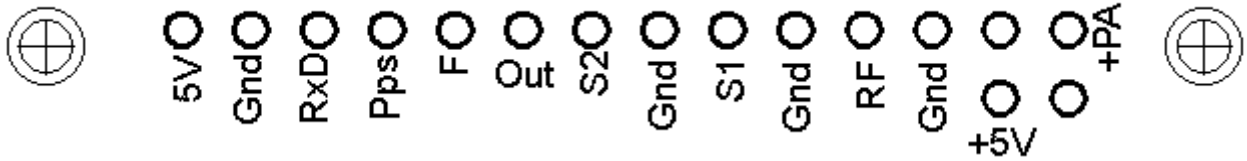

The diagram shows the connection pads along the edge of the board. The pin-spacing is 0.1-inches and a suitable connector could be used if desired. These are further described in the following sections. From left to right:

Label	Group	Description
5V	GPS	+5V supply to GPS module
Gnd	GPS	Ground connection to GPS module
RxD	GPS	Serial data input from GPS module
Pps	GPS	1 pulse per second input from GPS module
F	Future	No connection – for future enhancements
Out	Options	Digital logic level RF output
S2	Buttons	Optional external button S2, switch to Gnd
Gnd	Buttons	Ground for optional external buttons
S1	Buttons	Optional external button S1, switch to Gnd
Gnd	RF	Ground for RF output
RF	RF	RF output
Gnd	Power	Ground connection to Power supply
+5V	Power	+5V power supply
+PA	Power	PA power supply – may be connected to +5V

5.2 Connection for basic operation

For the most basic operation of this kit as QRSS transmitter using 5V supply, it needs only a power supply and RF output connection.

To allow use of a higher voltage supply for the PA, the PA voltage is not connected to +5V on the PCB. So to run the transmitter using the 5V supply, be sure to connect a wire between the +5V and PA pins, as shown by the short red vertical line in the diagram (right).

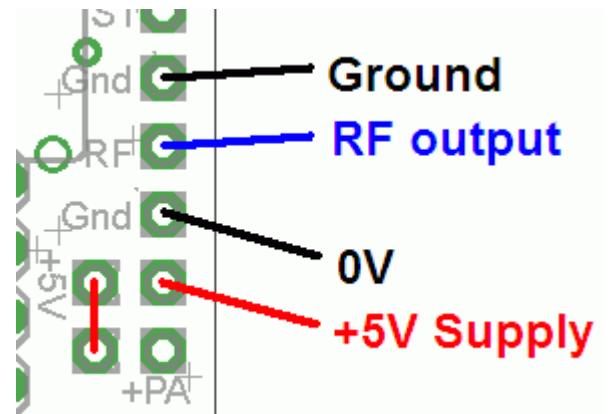

5.3 Alternative button mounting option

If you wish you may use an external pair of buttons to control the kit. The button input signals are available at the edge of the board, labelled S1 (right button) and S2 (left button). The buttons should be of the push-to-make variety. The right button should be connected between the S1 signal and ground; similarly the left button should be connected between the S2 signal and ground.

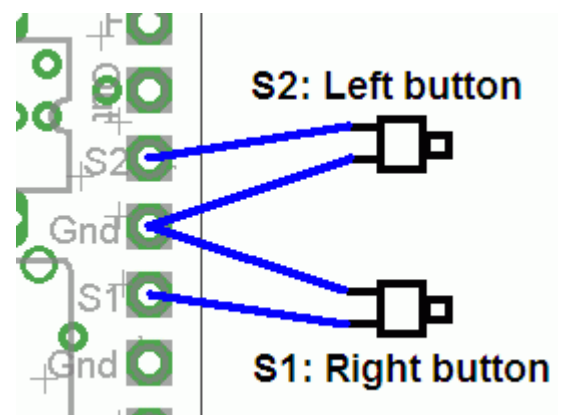

5.4 Optional connection of GPS module

A GPS module may be connected to the kit, to provide frequency stability, accurate time, and latitude and longitude which can be converted to Maidenhead locator format for encoding in the WSPR message transmission.

Check that your module is powered from 5V. Many modules specify a 3.3V supply – in this case you will need to provide an external 3.3V voltage regulator. Where a 3.3V GPS module is used, the serial data and 1 pulse-per-second (pps) inputs are not a problem for the 5V microcontroller on the kit PCB – no voltage level conversion is required.

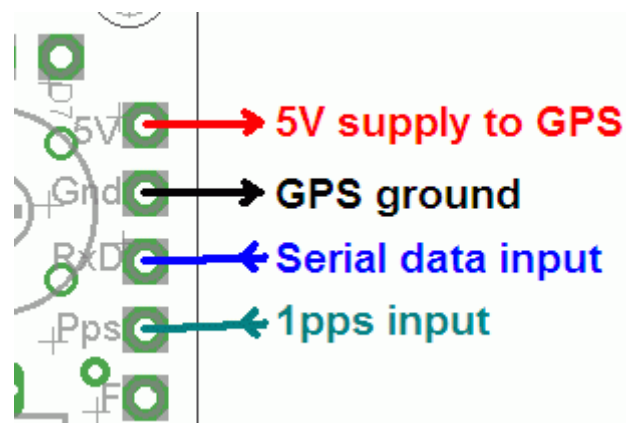

In cases where the location information is not required (modes other than WSPR) or you wish to enter it manually, the serial data input can be left unconnected. The 1 pps input is enough for the frequency lock function. Note that the frequency locking function can only operate if you have selected a wait period between message transmission (i.e. a non-zero “Frame” parameter).

See operation instructions below for details on how to configure the GPS interface.

5.5 Higher power output

The kit provides around 150mW of output power using a 5V supply and a single BS170 transistor (depending on the band). The transistor gets slightly warm to the touch. If higher output powers are desired, this can be achieved by using a higher supply voltage for the Power Amplifier (PA). The microcontroller must still be run at a voltage not exceeding its 5.5V rating (5V is recommended). To facilitate running the PA at higher voltages to provide more power, the PA supply connection is a separate pin.

At higher supply voltages and power outputs, the heat dissipation in the BS170 will increase and its temperature will be higher. Provision is made on the PCB for two more transistors in parallel with the first. This will slightly increase the power output even at 5V supply, but more importantly at higher voltages it should share the heat dissipation between the devices.

It may be necessary to fix a heat sink to the transistors if the temperature rise is excessive. The transistors are sited near the edge to the board to facilitate this. Experiment is needed in this area, with PA voltages up to perhaps 12V.

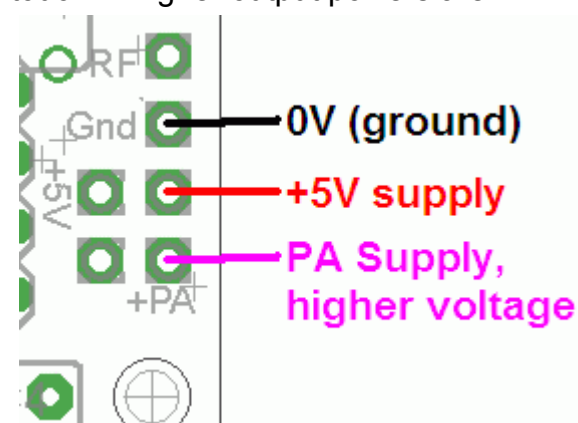

5.6 Audio frequency output

The kit can be used to generate audio tones for feeding to an SSB transceiver etc. In this case you can simply set the output frequency to the desired audio frequency, and feed the “RF” output to the microphone input. It is very important to note that this output is a just a 5V peak-to-peak square wave – to connect it to a microphone input (for example) you will need to reduce the signal amplitude considerably. In testing, I used a potential divider made of an 18K resistor and a 10-ohm resistor to ground. The mic input was connected across the 10-ohm resistor and provided a suitable signal amplitude.

Another possible way to use the AF output is to rectify it (diode + capacitor) and use that as a plain on/off keying signal to a CW transmitter. This would be suitable for CW and Hellschreiber modes, but not modes where a frequency shift encoding is involved.

6. Calibration

This section is REALLY IMPORTANT! It is very important to realise that by far the hardest part of any successful QRSS beacon operation, is tuning the oscillator to the correct frequency. For example, most 30m QRSS stations monitor a narrow 100Hz-wide band from 10,140,000 to 10,140,100. If you are much outside this, the chances are that nobody will see your signal. It is therefore essential either to adjust your output frequency using an accurately calibrated frequency counter, or an accurately calibrated receiver.

If you are going to use a GPS receiver module to provide a 1pps signal to the kit, no calibration is required: the kit will self-calibrate from the 1pps signal.

In the case that you will not be using a GPS signal, you need to calibrate the kit by entering the correct value of the 125MHz reference oscillator frequency into the "Ref. Frq." configuration setting.

It is possible that you have an accurate means to measure the 125MHz reference oscillator frequency itself by probing the correct point on the DDS module. However most kit builders will not have the necessary equipment, and such a measurement at VHF is not easy to make without itself risking disturbing the frequency.

The easiest method is to set the output frequency to something convenient such as 12.500000 MHz, and measure it. Measurement can either be by using an accurately calibrated frequency counter, or by setting up an accurately calibrated receiver with Argo and monitoring the output signal frequency that way.

Once you have measured the actual output frequency, you can calculate the required correction to the 125MHz reference frequency and enter it in the "Ref. Frq." configuration setting. For example, suppose you set the output frequency to 12.500000 MHz but you actually measure 12.500075. Your output frequency is 75 Hz too high. Since your output frequency setting is 10 times less than the 125MHz reference oscillator frequency, this means that the actual reference oscillator value is 750Hz too high. So enter 125,000,750 in the "Ref. Frq." setting.

7. DDS Module Stability

Here's an extremely important tip regarding the stability of the DDS module. If you just wire everything up and go on air, you would surely be ashamed to see how horrible your signal will probably look:

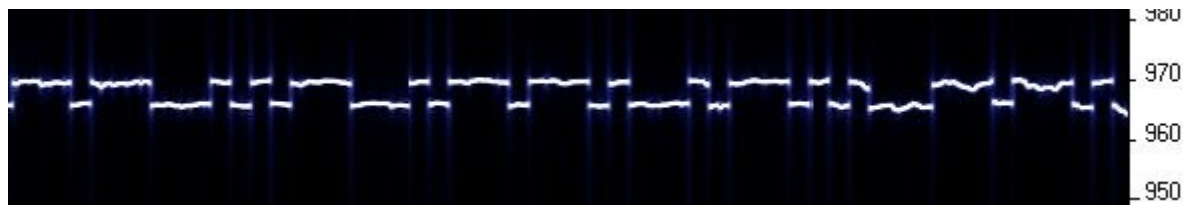

Obviously the DDS module was designed for something else, not just our QRSS passion, and the stability at Hz-level wasn't important. My own theory is that there are temperature sensitive components within the 125MHz crystal reference oscillator, which take time to all reach the same temperature. When they do, the temperature coefficients largely cancel each other out. But in the short term, while the different components are experiencing slightly different temperatures, the frequency can shift considerably. I believe that even small air currents over the oscillator case are enough to alter the local temperature and cause frequency instability.

I have found that in practice there are two easy ways to solve this problem. Preventing the instability is very important before putting the transmitter on air.

- 1) If you put the kit into an enclosure, such that you've removed any air currents around the crystal oscillator, the frequency instability disappears.
- 2) Attaching (e.g. with glue) a small heatsink to the crystal oscillator can also cures the frequency instability. I found that almost any heatsink will do. Even take the smallest most pathetic coin in your country and place it on top of the crystal oscillator, and the frequency instability is cured. In fact even non-metal will do it – a piece of plastic, for example – which also adds weight to the air current theory, since anything you put on top of the crystal oscillator stops air currents altering the temperature so easily.

Arguably a heatsink may be a good idea in any case, to slow down temperature changes of the crystal oscillator anyway. Either way: just don't leave the crystal oscillator in the open air.

Below see the result of placing a coin on the crystal oscillator.

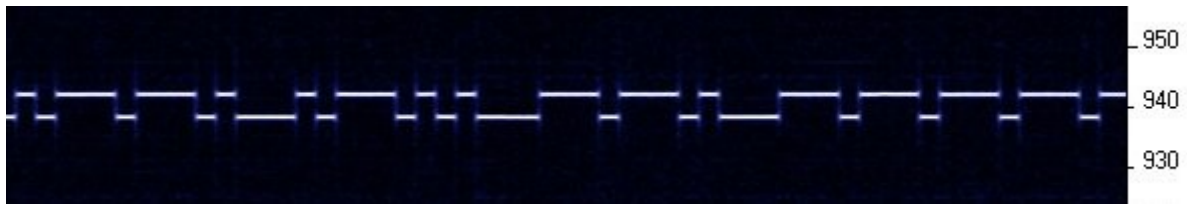

8 Resources

Please see the kit page <http://www.hanssummers.com/qrssultimate2> for any information on latest updates and issues.

Further references are listed in the Operation manual.

Analog Devices DDS information: <http://www.analog.com/en/rfif-components/direct-digital-synthesis-dds/products/index.html>

9. Version History

1 24-Mar-2013

- Initial draft version, for firmware version v2.00 and beta testers

2 20-Apr-2013

- First official version, accompanies firmware version v2.01
- Bug fix: after frame wait, frequency didn't return to correct frequency until tone changed
- Bug fix: WSPR did not work with any system clock frequency > 16,777,216 Hz
- New menu item "Inv. GPS" for triggering on a negative edge 1pps signal
- Impose limit of 200 seconds on the speed setting, to prevent arithmetic overflow
- Pressing right button during Run resets frequency and forces key-up

3 07-Jun-2013

- Separated assembly and operation manuals into different documents

4 01-Jul-2013

- Manual version for PCB revision 2