

# QLG1 GPS Receiver kit

## 1. Introduction

Thank you for purchasing the QRP Labs QLG1 GPS Receiver kit. This kit will provide a highly sensitive, highly accurate GPS receiver module, using the popular MediaTek chipset. This chipset features high sensitivity (as good, or better, than any other popular chipset) and an extremely accurate 1pps time pulse (10ns rms). The kit features provide a number of advantages compared to using a ready-built GPS module:

- 1) A kit – fun and educational to build – easy construction with no SMD components
- 2) High sensitivity: the large ground plane area provides an additional 7.5dBic of antenna gain, compared to a typical patch antenna arrangement in which the PCB is the same size as the patch
- 3) Built-in patch antenna, or the ability to connect your own external antenna via SMA if you wish
- 4) Hobbyist-friendly, 0.1-inch pitch connections
- 5) Three on-board LEDs provide a visual indication of what is going on
- 6) Proper 5V level conversion, no need for any pull-up resistors
- 7) Direct connection to QRP Labs kits by shielded cable, no need for pull-ups or capacitors

## 2. Antenna

The QLG1 GPS receiver kit can be built with two antenna options: either an on-board patch antenna, or an externally mounted active antenna (with SMA connector). The module can supply a regulated voltage suitable for powering the external antenna. The external antenna option may be useful if you wish to mount the antenna separately to the module; furthermore active external antennas typically provide the highest receive sensitivity. This may be useful in particularly challenging locations. However, the supplied custom-tuned patch antenna is already highly sensitive and will be suitable for most situations.

### Antenna gain

This chart of antenna gain vs size of the square ground plane dimension, is extracted from the manufacturer's datasheet.

The QLG1 PCB is sized 3.6 x 2.5 inches (91 x 64mm). The right hand side of the PCB is used for the voltage regulator and level converter circuits. In this way, the patch antenna is mounted on the reverse of the PCB, in the middle of a virtually un-interrupted ground-plane 64 x 64mm. This is indicated on the chart by the red line. You will note that it provides 7.5dBic gain over a more typical 30 x 30mm sized ground-plane. This is an important feature of the QLG1 kit, providing high sensitivity!

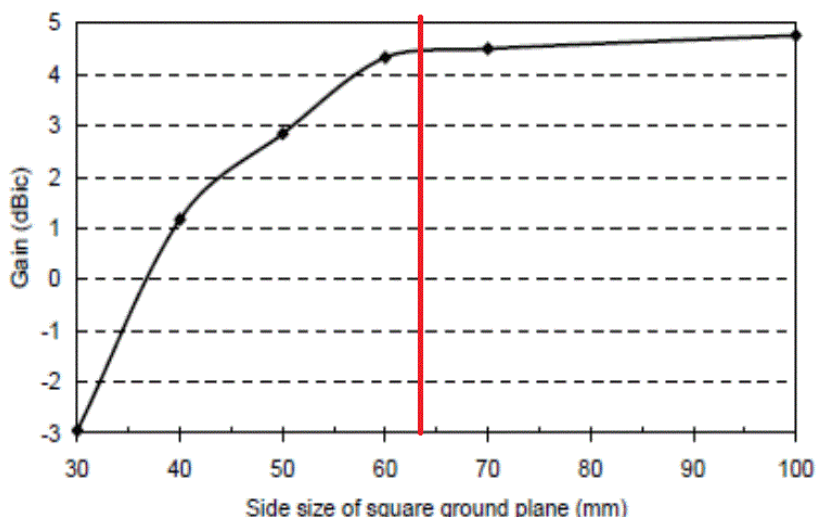

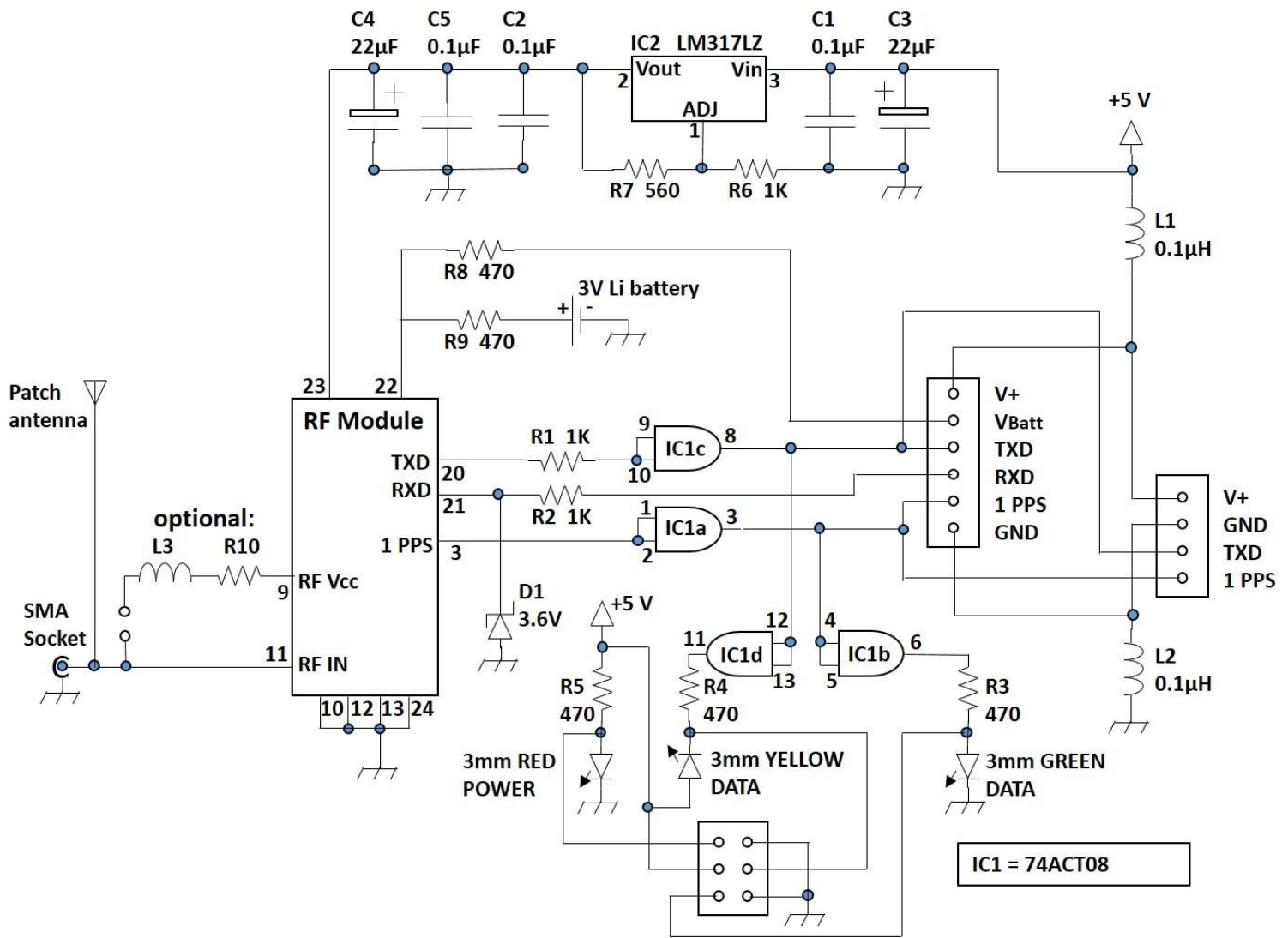

### 3. Design

The design is quite simple. Note the circuit diagram above. The GPS receiver RF module does all the hard work. The additional circuits are supply filtering, voltage regulation (the module requires 3.3V operation), level shifting, and LED indication.

Supply voltage filtering is undertaken by two 0.1µH inductors in series with both the +5V and ground supplies, and plenty of smoothing/decoupling capacitors (the 0.1µF and 22µF capacitors). The voltage regulator is an LM317LZ configured for 3.3V output. Additionally there is a 3V Li rechargeable battery on the board. This is charged automatically during operation. When power is removed, it retains ephemeris information in the RF receiver module. This enables a faster fix, next time the GPS receiver is powered.

The data output and 1pps output from the RF module are at 2.8V level (via internal voltage regulation within the module). The 74ACT logic family are perfect for the purposes of level conversion, because the “high” voltage threshold specification for this family is below the 2.8V “high” output voltage of the RF module. This is therefore converted to 5V by the 74ACT08 quad AND-gate, which is configured as four buffers. The voltage to the serial data input of the RF module is restricted by zener diode D1.

The kit includes three 3mm LEDs. It is suggested to fit the Red LED to be permanently on, to show power to the board. The Yellow and Green LEDs indicate respectively, serial data and the 1pps signal. They are driven by the remaining two AND gates of the 74ACT08. Note that the serial data output is idle-high, i.e. at 5V in the pause between data bursts. Therefore the yellow LED is connected to 5V, so as to light when the serial line is LOW. It will therefore pulse once per second during the data burst. The green 1pps LED will only pulse once a GPS fix is attained – the Green colour traditionally indicating “All is well”.

## **4. Parts List**

### **4.1 Resistors** (may be supplied either with 4-band or 5-band colour codes, see below)

R1	1K resistor (brown-black-red-gold OR brown-black-black-brown-brown)
R2	1K resistor (brown-black-red-gold OR brown-black-black-brown-brown)
R3	470-ohm resistor (yellow-purple-brown-gold OR yellow-purple-black-black-brown)
R4	470-ohm resistor (yellow-purple-brown-gold OR yellow-purple-black-black-brown)
R5	470-ohm resistor (yellow-purple-brown-gold OR yellow-purple-black-black-brown)
R6	1K resistor (brown-black-red-gold OR brown-black-black-brown-brown)
R7	560-ohm resistor (green-blue-brown-gold OR green-blue-black-black-brown)
R8	470-ohm resistor (yellow-purple-brown-gold OR yellow-purple-black-black-brown)
R9	470-ohm resistor (yellow-purple-brown-gold OR yellow-purple-black-black-brown)
R10	Not supplied – space is provided on the PCB for an active external antenna voltage supply

### **4.2 Capacitors**

C1	0.1uF (ceramic, marking 104)
C2	0.1uF (ceramic, marking 104)
C3	22uF (electrolytic)
C4	22uF (electrolytic)
C5	0.1uF (ceramic, marking 104)

### **4.3 Semiconductors**

IC1	74ACT08, 14-pin DIP chip
IC2	LM317LZ voltage regulator, three-wired TO92
D1	3.6V zener diode
LED, red	3mm red LED for power indication
LED, yellow	3mm yellow LED for serial data output indication
LED, green	3mm green LED for 1pps indication

### **4.4 Inductors**

L1	0.1uH axial inductor
L2	0.1uH axial inductor
L3	Not supplied– space is provided on the PCB for an active external antenna voltage supply

### **4.5 Miscellaneous**

Printed Circuit Board (PCB), 91 x 64mm size  
Mediatek chipset GPS engine RF module, pre-soldered to PCB  
25 x 25mm ceramic patch antenna, custom-tuned to match the PCB layout and ground-plane  
3V rechargeable Lithium coin cell battery  
4pcs 12mm nylon hex spacer  
4pcs M3 nylon screw

## **5. Construction**

Parts placement is defined by the silkscreen printed legend on the PCB, so please observe it carefully, paying particular attention to the correct orientation of all the semiconductors, and the two electrolytic capacitors C3 and C4.

Note that components R10 and L3 are not supplied in the kit. The PCB has space for these components, which may optionally be fitted for those wishing to supply power to an external active antenna.

Please refer to the parts placement diagram below.

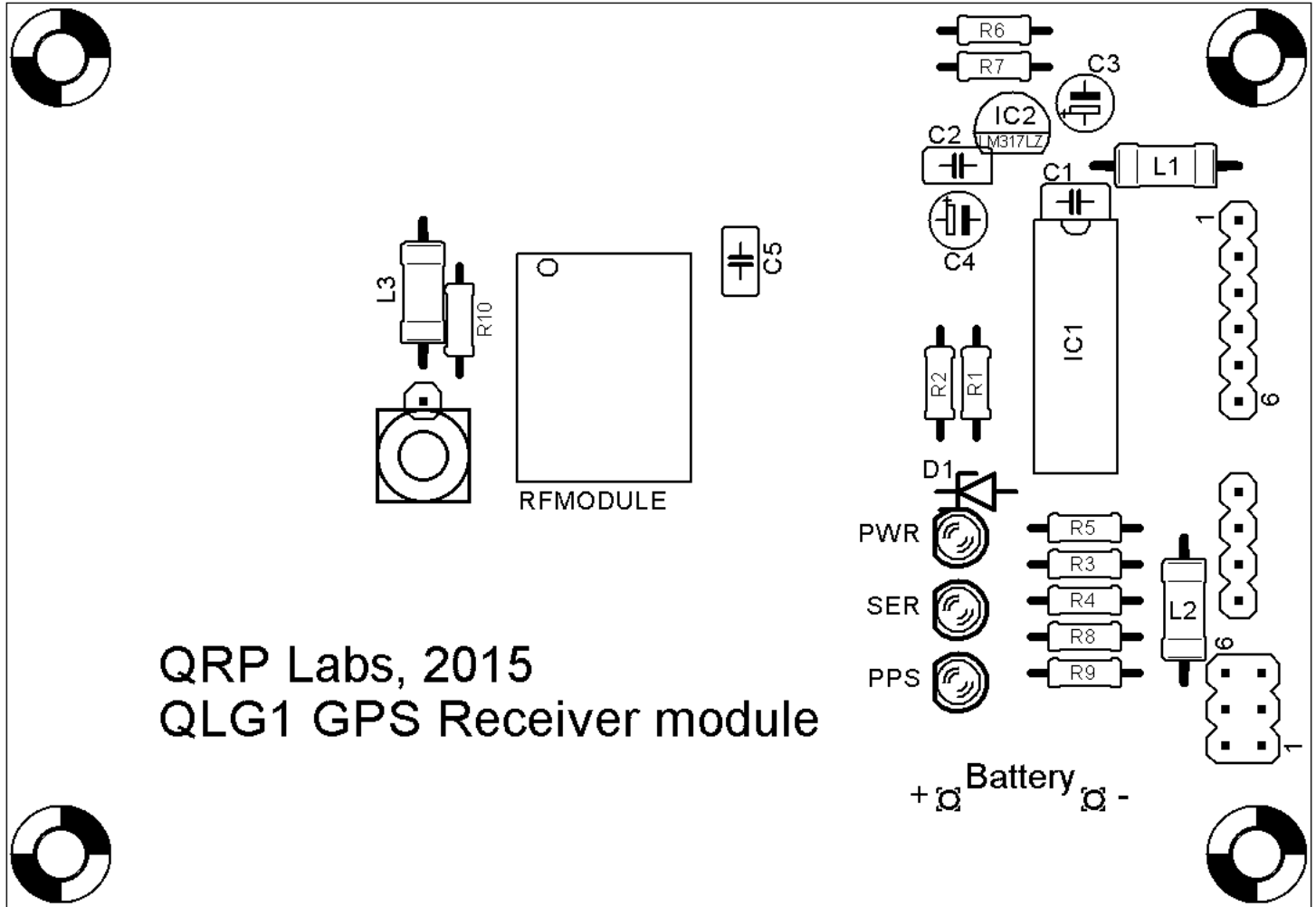

Pay special attention to the orientation of the semiconductor IC1. The dimple in the PCB silkscreen must be aligned with the dimple at the top of IC1.

It's a good idea to use a jeweller's loupe like the one pictured, or a magnifying glass, to inspect each soldered joint. A strong light is also very useful. Look for excess solder that could cause short circuits (solder bridges) to adjacent tracks. Also look for joints where the solder has not correctly flowed into the joint, i.e. adhered to the component lead and the PCB.



The QLG1 PCB has a ground plane on both sides of the board. Component connections to the ground plane need a little extra heat, because of the heat dissipation of the ground plane. Even though the solder pads are thermally "isolated" in the PCB layout, there is still significant heat loss into the ground plane. My suggestion for components with a ground connection, is to solder the non-ground lead(s) first – this anchors the component in place and makes it easier to get a good connection when you come to soldering the grounded lead. Again, use the jeweller's loupe to make a careful inspection.

The order of construction is not important. However, a good principle to follow is to install the smaller components first, so that the larger ones do not prevent easy access.

In the following photograph, all the resistors, capacitors, inductors, LM317LZ voltage regulator (3-pin TO92 package), 74ACT08 chip, and 3.6V zener diode have been fitted. Be careful to ensure the correct orientation of the semiconductors (IC1, IC2, zener diode); also the electrolytic capacitors C3 and C4. The silk-screen legend on the PCB may be too small to read, so please refer to the parts placement diagram.

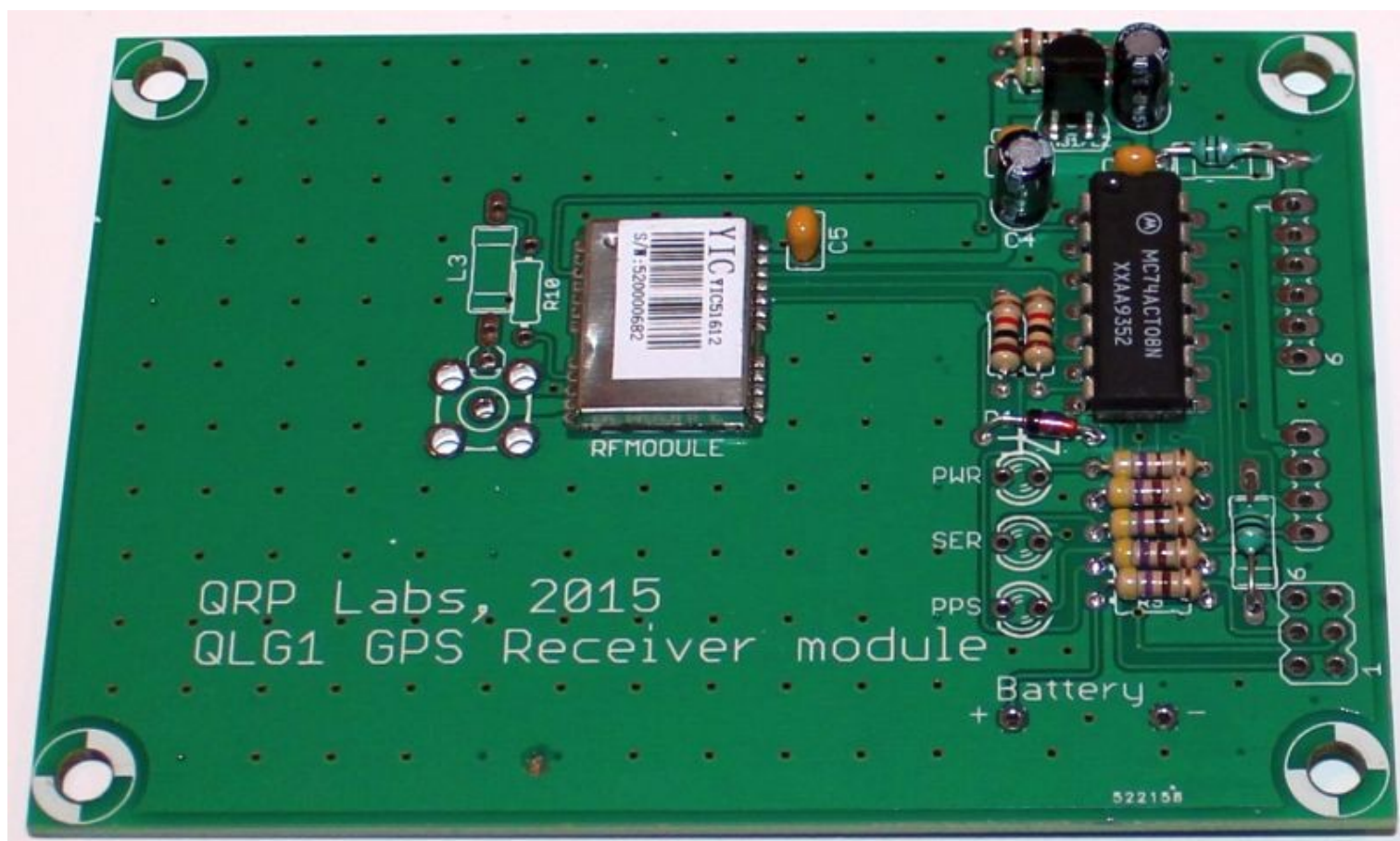

## Battery

Correct orientation of the battery is particularly critical! Since the battery will already hold some charge when it arrives, you must ensure that it is NOT inserted into the PCB in the wrong way, even temporarily – since it would supply reverse power to the RF module and potentially damage it.

The 3V rechargeable battery has two pins, that fit the holes on the board. The TOP of the battery, is the positive connection. This pin fits the hole labelled “+”. Please study the photograph to the right, showing the battery correctly installed on the board.

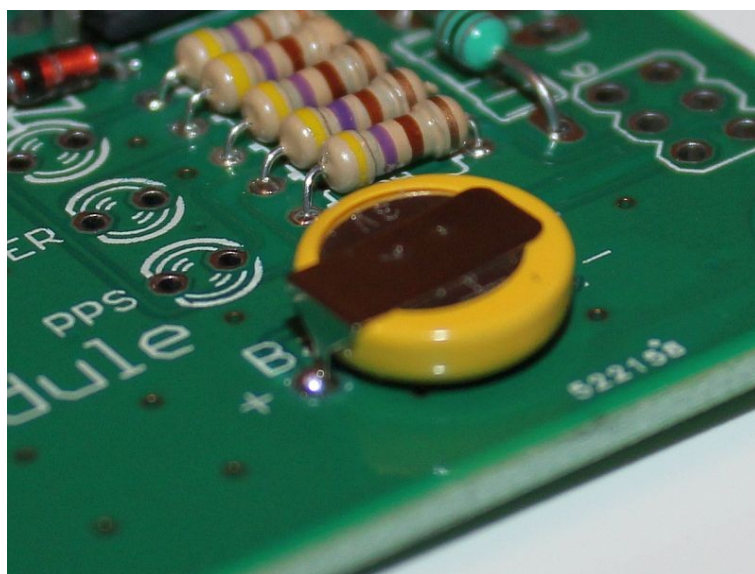

When soldering the battery, please make it quick. Hot Lithium probably is not a good idea.

## LEDs

It is critical of course, to ensure correct LED orientation. The cathode of the LEDs is indicated by the flat on the body of the LED. However, on 3mm LEDs the “flat” is not so easy to see (though quite clear, using magnification). So note that the cathode is also indicated by the shorter wire (before you’ve cut them!) and also by the larger electrode. The larger electrode can be seen clearly if you hold the LED in front of a strong light. The diagram to the right illustrates the three ways of identifying the LED cathode.

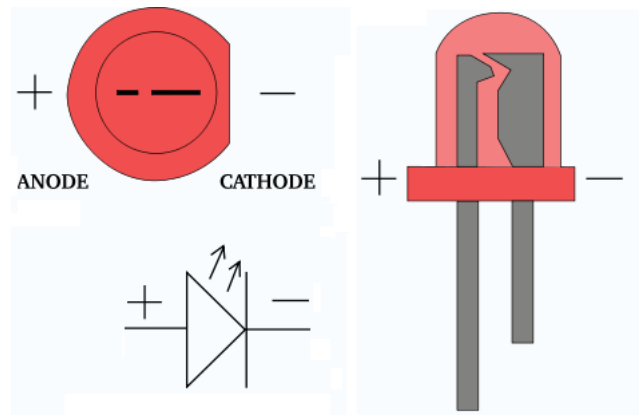

In actual operation using the patch antenna (not externally mounted active antenna), the patch antenna is fitted on the solder-side of the board (see next section). This side will be facing up so that it has a good view of the sky. In this case, it is helpful to install the three LEDs on the solder-side of the board. The side without the silkscreen printed component outlines. This will ensure that you can see the LEDs in operation.

If you are using an external active antenna, then you could continue to use the LED’s on the component side of the board. Additionally, 2 x 3 header connection pads are provided, in case you want to wire the LEDs to be mounted off-board, for example, to fit into an enclosure or front panel (headers not supplied).

Regardless of whether you wish to have the LEDs fitted on the component or solder side of the PCB, you need to ensure the flats (cathodes) of the LEDs are aligned with the silkscreen on the PCB. The cathodes/flats/short-wires are inserted into the PCB holes nearest to the PCB centre.

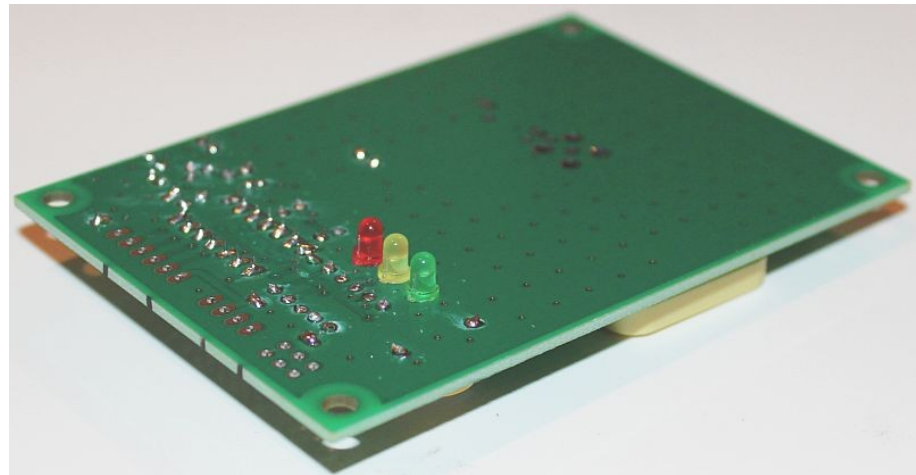

This photograph shows the usual method of assembly, with the LED’s on the solder-side of the PCB so that with the patch antenna installed on-board, they’ll be visible.

## Patch antenna installation

The supplied 25 x 25mm patch antenna has been custom-manufactured, with tuning to match it to the characteristics of this PCB. The tuning is indicated by the small cuts you may be able to see in the metallic surface of the top side of the patch antenna. **Do not be tempted to substitute another patch antenna, which will not have been tuned to match this PCB layout!**

To install the patch antenna, first remove the plastic film that protects the self-adhesive sticker on the underside of the antenna, as shown in these two photographs (far right: after removal).

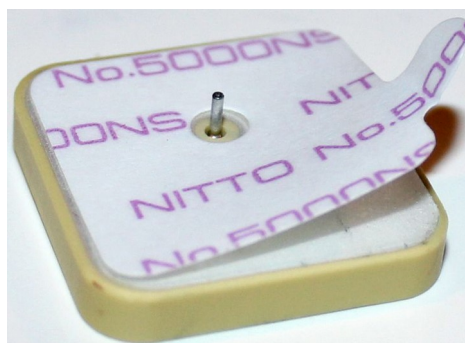

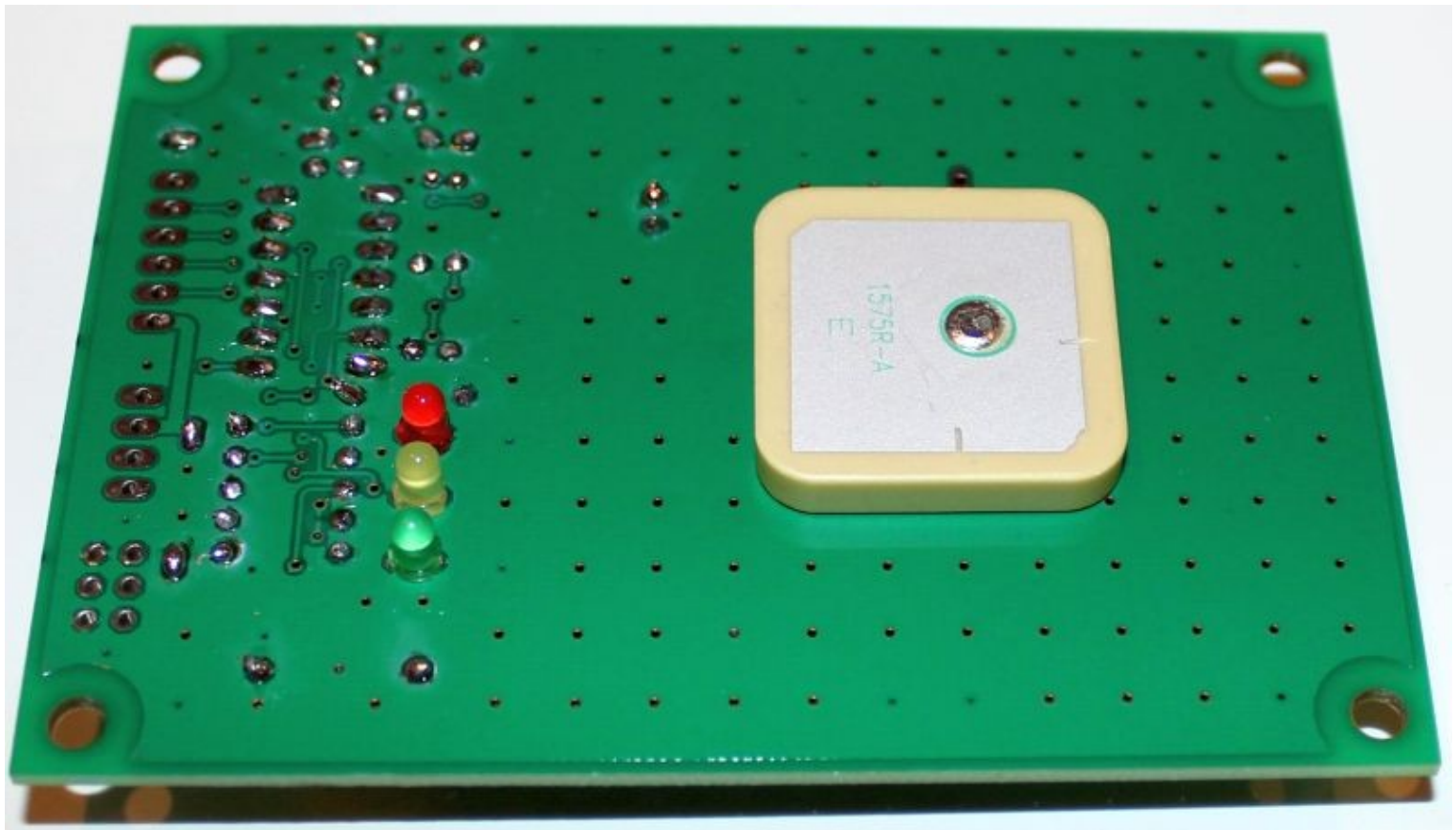

The patch antenna connection pin is not in the exact centre of the square patch. Please refer to the photograph (above). The connection pin should be furthest away from the through-hole components section of the PCB, as shown. The patch should be positioned on the solder side of the PCB.

Insert the connection pin of the patch antenna into the centre-hole of the SMA socket. The photograph (right) illustrates the connection pin location. Solder the connection on the component side of the PCB.

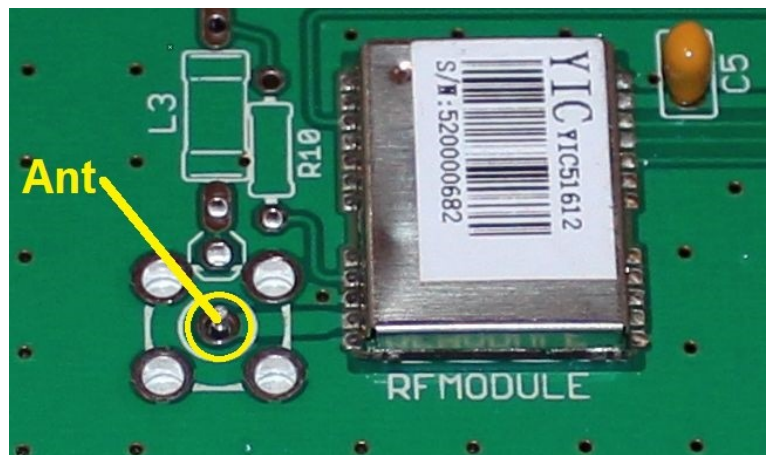

### **Remote active antenna installation**

If you decide to use an external active antenna, then do not install the supplied patch antenna. Instead, you can fit a SMA socket such as the one pictured here (left).



Install the SMA socket on the PCB as shown in the photograph (right).

In this case you may also need to supply power to the external active antenna.

Then you should fit R10 and L3 (not supplied).

Typically R10 should be 10 ohms, and L3 27nH (or a ferrite bead). You will need to solder a wire from the

lower end of L3, to the SMA centre connector. This arrangement supplies power to the external antenna, from the RF Vcc supply output of the RF module. Note that it does not have short-circuit protection!

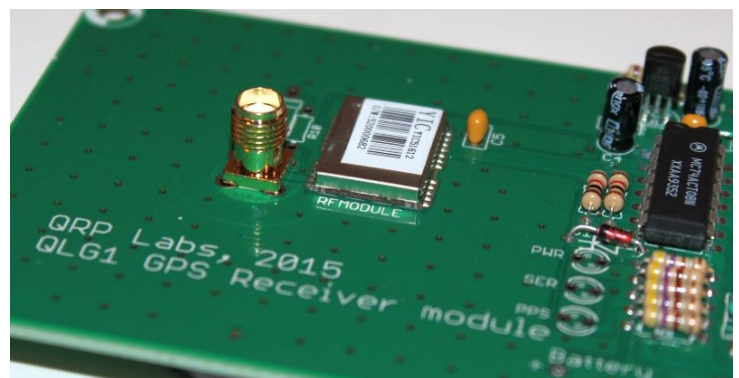

## Mechanical mounting considerations

The kit is supplied with four 12mm nylon M3 hex spacers, and four nylon M3 screws. The PCB has a suitable mounting hole in each corner.

The patch antenna specifications recommend that the distance between the ground-plane and any conducting materials below it, should be a minimum of 10mm.

When using the supplied patch antenna, the recommended mounting of the QLG1 PCB should therefore involve the PCB orientated with the component side downwards, and the patch antenna facing up to the sky. The hex nylon spacers should be used as pillars, suspending the PCB above the enclosure. The hex nylon spacers will be on the component side of the PCB (lower), with the screws on the solder side (upper).

The enclosure material must NOT be conductive, which would shield the patch antenna!

If using an externally mounted active antenna, the mounting considerations are much less critical.



## Input/output signal connections

The diagram (right) shows a section of the silkscreen printing from the component side of the QLG1 PCB, at the right side of the board.

There are two sets of connections, a 6-way set and a 4-way set. Both use 0.1-inch pitch pads, suitable for using standard 0.1-inch pin header connectors (not supplied with the kit), or soldering wires. The pads are large and easy to solder to.

The 6-way set of connections provides access to the full set of signals, for general purpose use of this GPS receiver module. Note that TXD is the serial data output of the module, at 5V Logic levels. The 1 pulse per second (1pps) timing signal is also 5V. The pulse is 100ms long and active-high (the leading edge of the pulse indicates the 1 second event). RXD is the serial data input signal, at 3.3V logic level; however 5V logic level inputs are also supported due to the onboard zener diode D1.

The 4-way set of connections is intended for connection of the QLG1 GPS receiver module to the Ultimate3S QRSS/WSPR transmitter kit, and other QRP Labs kits. These are the only four signals required by these kits, which do not communicate serial data back to the GPS, they only listen to the GPS serial data stream and 1pps signals.

## Connecting the QLG1 to an Ultimate3S QRSS/WSPR kit

The 4-way connector on the QLG1 can be connected directly to the 4-way connector of the U3S (and other QRP Labs kits), via a length of shielded cable. No pull-up resistors, extra voltage regulator, or smoothing/decoupling capacitors are needed since these are all already incorporated into the QLG1. The order of connection pads on the QLG1 is also the same as those on the U3S. Note that the QLG1 TXD (output) signal connects to the U3S RXD signal (input). The cable shield should be connected to ground at the U3S end only, not the QLG1 end. 2m or 3m of cable is typically a good length to use.

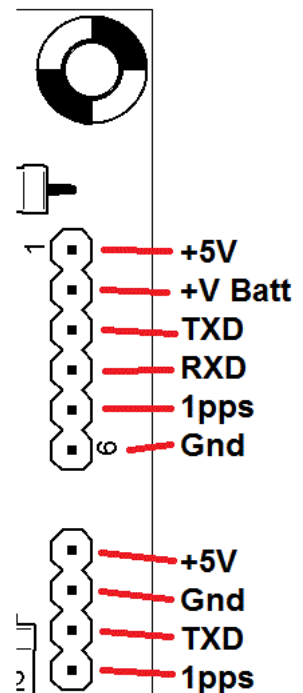



## Connecting LEDs off-board

The LEDs can also be connected off-board, you may wish to do this if you are considering boxing the QLG1, and want to still see the status LEDs, for example on a front panel.

The PCB has a 2 x 3 connector pad at the bottom right (component side) as in this diagram (right). Each pair of 2 connections is for one LED, as shown. The cathodes are the pads nearest the board edge.

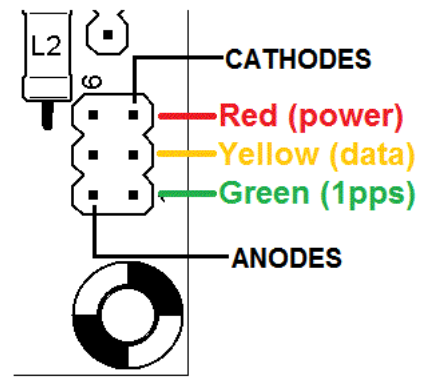

## LED indication in operation

**RED** The red power LED will always be lit, when power is applied to the QLG1 board.

**YELLOW** The data LED pulses in time with the serial data burst

**GREEN** The green 1pps LED will flash once per second, for a duration of 0.1 seconds

Note that the green LED will not flash (indicating 1pps signal) until the module has received sufficient satellites to compute a position fix solution. This can take some time, particularly the first time the unit is powered up. Initial acquisition of a satellite requires higher Signal to Noise Ratio (SNR) than tracking. Once acquired, the satellites orbital characteristics are stored, so that subsequent tracking is possible at the lower SNR, as soon as the satellite comes into view. Download of all the satellite orbital data in the constellation can take around 1 hour. So it is quite normal for performance of a GPS module to improve during the first hour after power up (in terms of number of tracked satellites etc).

Until all the satellites are received the yellow data LED may pulse somewhat erratically, not necessarily producing one data burst per second.

Once the fix is computed, the 1pps signal is enabled. The green LED will flash for 0.1 seconds, starting with the commencement of each second. The data burst is initiated at the end of the 0.1 second pulse, and lasts for perhaps 0.5 seconds (varies depending on data payload).

## Default Baud Rate

The default baud rate of the QLG1 is 9,600 baud. This is compatible with the default settings of the Ultimate3S QRSS/WSPR TX kit (and other QRP Labs products). The list of default NMEA sentences is described in a later section. The RF module (Mediatek chipset) can also accept serial commands that change its baud rate and the NMEA sentences in the serial data burst. This is beyond the scope of this document.

## Powering from 3.3V

The QLG1 GPS Receiver module can also be powered at 3.3V if desired. In this case, simply do not install the LM317LZ voltage regulator, and you may also omit R6 and R7. Instead, install a wire link as shown (right), to bypass this voltage regulator.

When powering with 3.3V, the TXD and 1pps output signals will also have 3.3V levels.

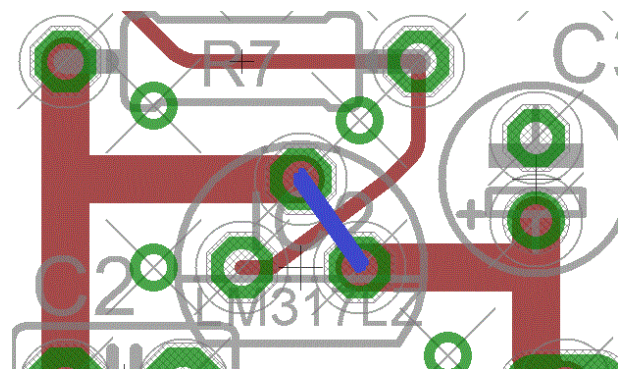

## 6 Resources

Please see the kit page <http://www.qrp-labs.com/qlg1> for information on latest updates and issues.

The kit page also has a copy of the datasheet for the RF module. This datasheet contains the RF specifications, and also the details of the NMEA sentence structure.

Finally, please join the QRP Labs YahooGroups forum, if you have not already. The forum members can provide support for any questions regarding issues, and share your success stories too.

## 9. Version History

**0**                    **10-Jun-2015**

- First version

**1**                    **05-Apr-2016**

- Correction to page 7, “components side” should be “solder side”, for positioning the patch antenna

**2**                    **04-May-2016**

- Correction to remove the reference to an IC socket, which is not in fact used or supplied in this kit. Also clarification that pin headers are not supplied either.

**4**                    **07-May-2020**

- Correction to page 6, “components side” should be “solder side”, for positioning the patch LEDs

**5**                    **28-May-2020**

- Correction to schematic, 560-ohm resistor was incorrectly written as 570.