

Polyphase network kit

PCB Rev 2

1. Introduction

This polyphase network module is designed to be used with the QRP Labs receiver module kit. It takes as inputs, four phase audio from the Quadrature Sampling Detector (QSD) on the receiver board. The inputs are fed into a 4-column phase shift network. The output is single-sideband audio.

Construction is reasonably straightforward. The board is necessarily rather compact, to fit the receiver module. A fine-tipped soldering iron is recommended. All components are leaded through-hole type.

2. Parts List

Resistors

R34, R35, R36, R37, R38, R39, R40, R41	2.7K (red-purple-black-brown-brown)
R1, R2, R3, R4	4.7K (yellow-purple-black-brown-brown)
R5, R6, R7, R8	5.6K (green-blue-black-brown-brown)
R9, R10, R11, R12	6.8K (blue-grey-black-brown-brown)
R13, R14, R15, R16	8.2K (grey-red-black-brown-brown)
R17, R18, R19, R20	47-ohms (yellow-purple-black-gold-brown)
R42	100K preset potentiometer

Capacitors

C34, C35	10nF ceramic
C1..C16	22nF ceramic
C33, C37	220nF ceramic
C36, C38	10uF electrolytic

Semiconductors

IC5, IC6	LM4562 dual low-noise op-amp
----------	------------------------------

Miscellaneous

PCB	1.45 x 1.05 inch (37 x 27mm), double sided, through-hole plated PCB
3x Header	3x 3-pin header
3x Socket	3x 3-way pin header socket

3. Circuit description

The polyphase network is an audio phase shift network, consisting of columns of interconnected resistors and capacitors. It is capable of 90-degree phase shift across a wide audio range. The four columns in this circuit are designed for an optimised 90-degree phase shift across the centre of the audio range from 500Hz to 2000Hz, where we typically wish to receive and demodulate CW, QRSS and WSPR signals.

In this Rev 2 PCB, the 4 signals from the Receiver module arrive via 47-ohm series resistors (R17/18/19/20). These are found to prevent an instability which a few people had noticed.

The output of the network is two out of phase signals which are combined by an instrumentation difference amplifier formed by IC5A, IC5B and IC6A.

IC6B is a final audio pre-amplifier whose gain is adjustable by the 100K preset potentiometer R42. This stage can be used to boost the audio output to levels suitable for driving an audio power amplifier, for applications where this module will be used as part of a standalone receiver project. When used to drive a mono-input soundcard, the R42 setting is typically for very low gain, to avoid overdriving the sound card!

Power supply for the op-amps, and the mid-rail bias for the final stage IC6B, are supplied from the main receiver module PCB.

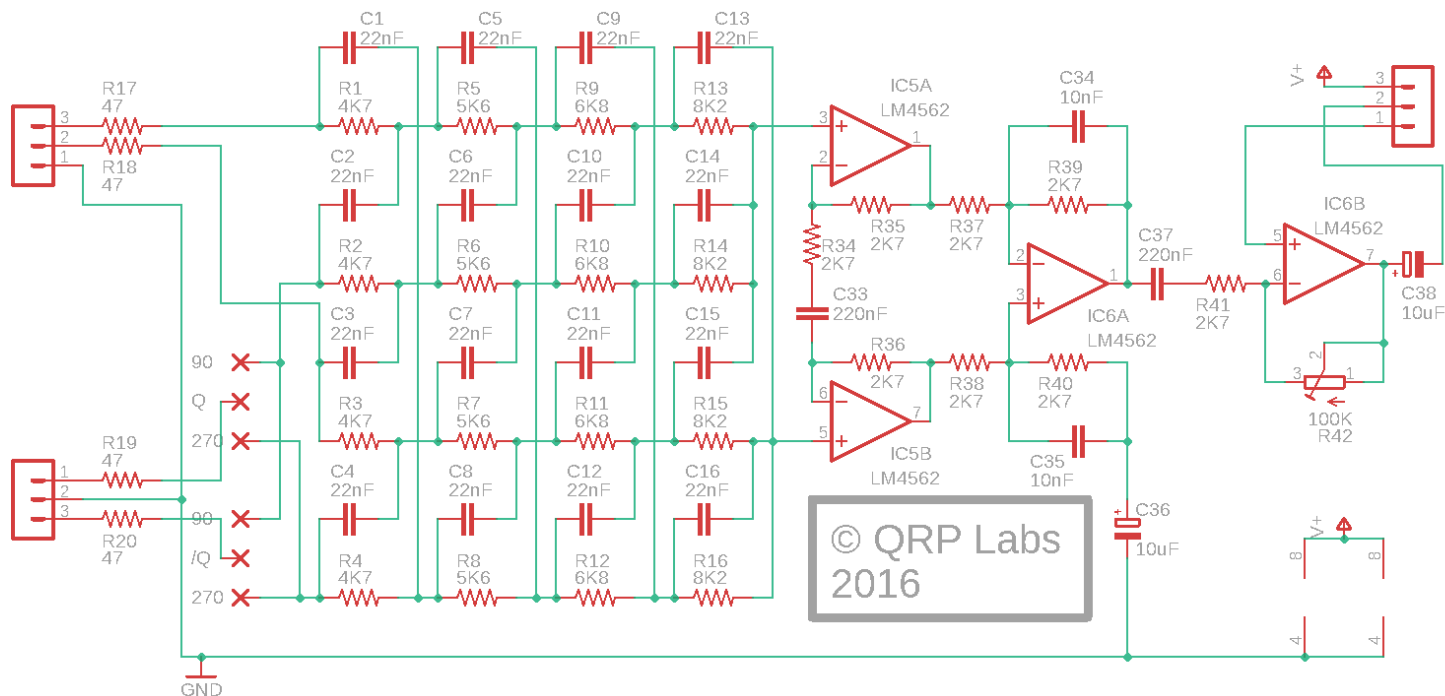

4. Assembly instructions

Assembly of this kit is quite straightforward. The usual kit-building recommendations apply: work in a well-lit area, with peace and quiet to concentrate, observe Electrostatic discharge (ESD) precautions. And **FOLLOW THE INSTRUCTIONS!!**

A jeweller's loupe is really useful for inspecting small components and soldered joints. You'll need a fine-tipped soldering iron too.

It is good to get into the habit of inspecting every joint with the magnifying glass or jeweller's loupe, right after soldering. This way you can easily identify any dry joints or solder bridges, before they become a problem later on when you are trying to test the project.



Please refer to the layout diagram and PCB tracks diagrams below, and follow the steps carefully.

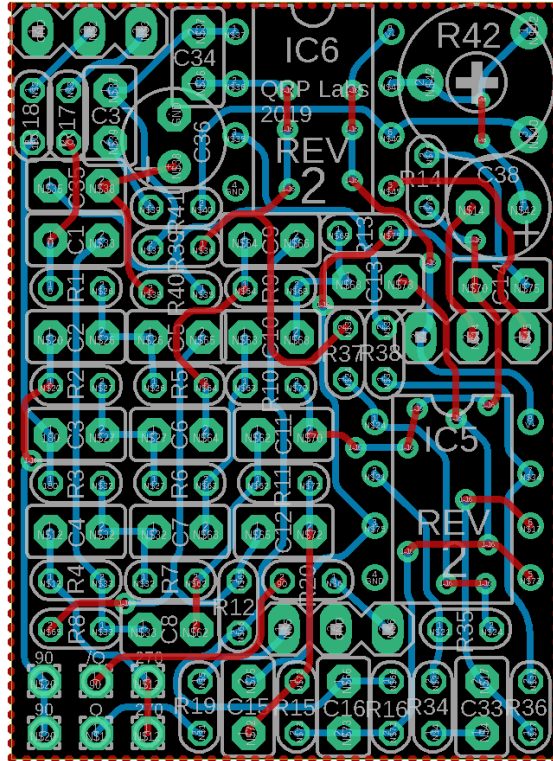
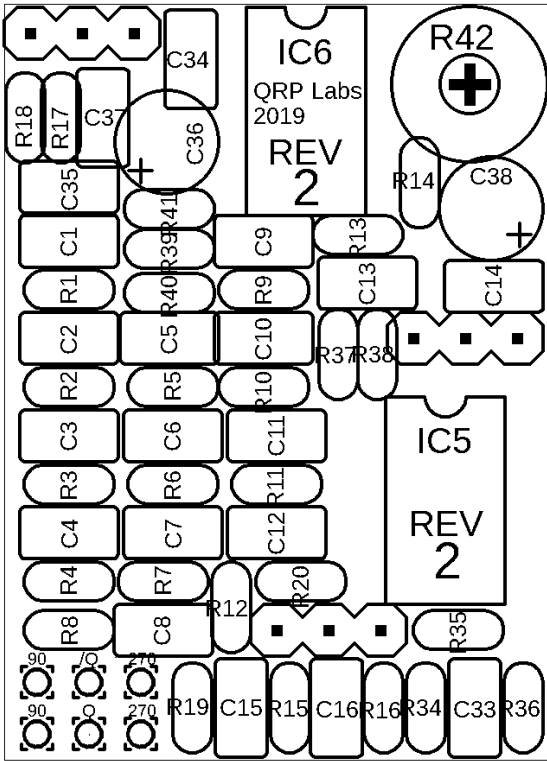

4.1 Inventory parts

Refer to the parts list and this picture. Identify each component, so you are ready for the construction!

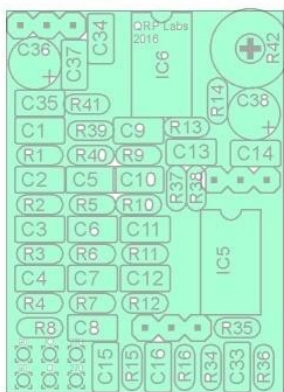

PCB 27mm x 37mm

2pcs LM4562
8-pin DIP



3pcs 3-pin
header

100K resistor



3pcs 3-way
socket

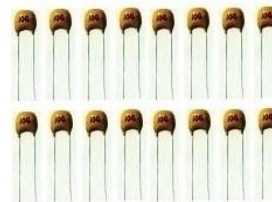

16pcs 22nF CC4
capacitor 5% 2.5mm



2pcs 10nF CC4 capacitor
5% 2.5mm



2pcs 220nF CC4
capacitor 5% 2.5mm



2pcs 10uF
capacitor 2.5mm pins



8pcs 2.7K resistor 1% 1/4 Watt

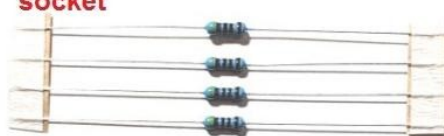

4pcs 4.7K resistor 1% 1/4 Watt

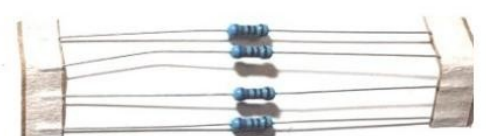

4pcs 6.8K resistor 1% 1/4 Watt



4pcs 47-ohm resistor 1% 1/4 Watt

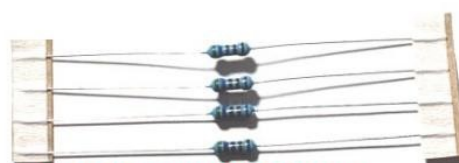

4pcs 5.6K resistor 1% 1/4 Watt



4pcs 8.2K resistor 1% 1/4 Watt

4.2 IC5 & IC6

First install the LM4562 op-amps. (Note, there are no IC1-4). Take care to align the dimple at one end of the IC with the dimple drawn on the PCB silkscreen. The pins of ICs are always spread too wide. It is normal to have to squeeze the two rows of pins gently slightly together to fit them in the PCB. Solder two pins at opposite diagonal ends of the chip. Then you can check that the chip is nicely seated on the board before soldering all the other pins. It is easy to make adjustments when only two pins are soldered, by re-heating the joints. But you cannot do that when you have 8 pins soldered! When you're happy with the position of the IC, solder all the other pins.

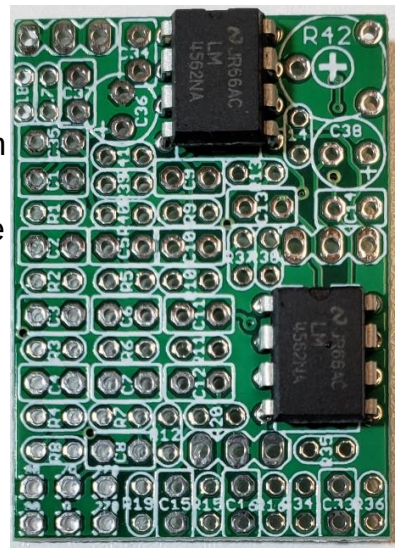

4.2 10nF capacitors

There are two 10nF capacitors in the kit, C34 and C35. You need to separate them carefully from the other capacitors! The 10nF capacitors are labelled "103". They are indicated in green on this diagram. Be careful: Don't mix up the capacitors!

When finished soldering the wires, cut off the excess wire length with wire cutters.

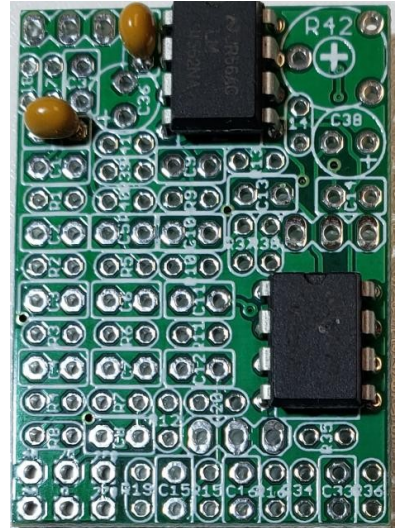
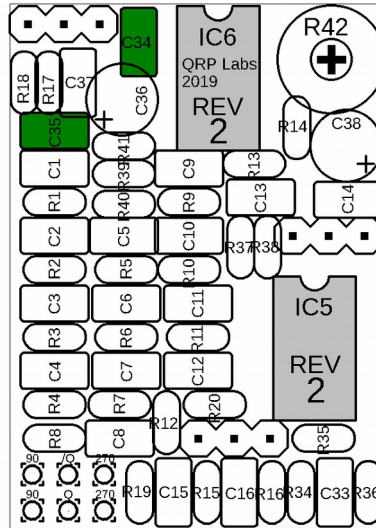

4.3 220nF capacitors

There are two 220nF capacitors in the kit, C33 and C37. You need to separate them carefully from the other capacitors! The 220nF capacitors are labelled "224". They are indicated in blue on this diagram. Be careful: Don't mix up the capacitors!

When finished soldering the wires, cut off the excess wire length with wire cutters.

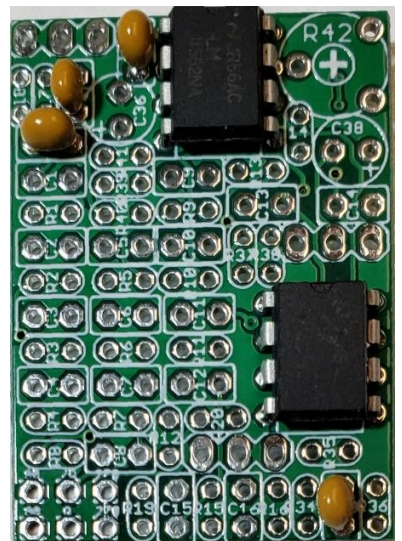
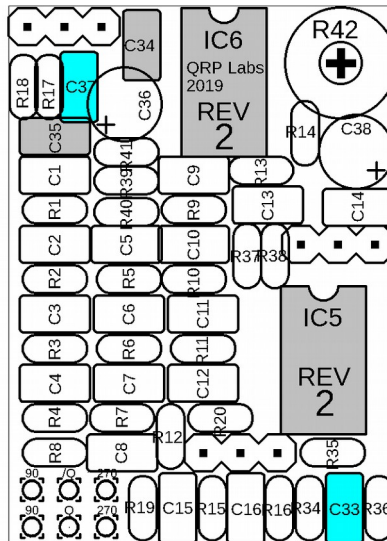

4.4 3-pin headers

These are the only components which have their long end on the BOTTOM side of the board and are soldered on the TOP!

So be sure to get this right... insert from the bottom, then solder on the top!

For each header, solder one pin first, then check the alignment before soldering the other two pins. The location of the pin headers is shown in brown on the following diagram.

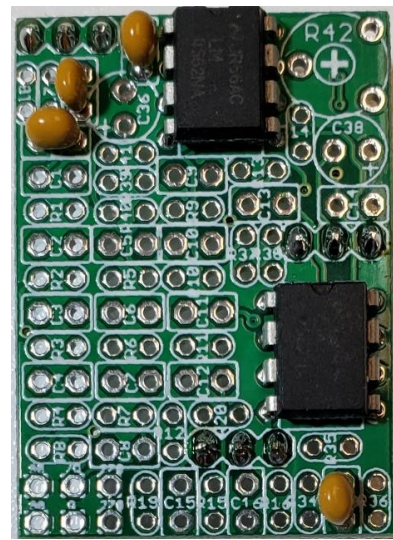
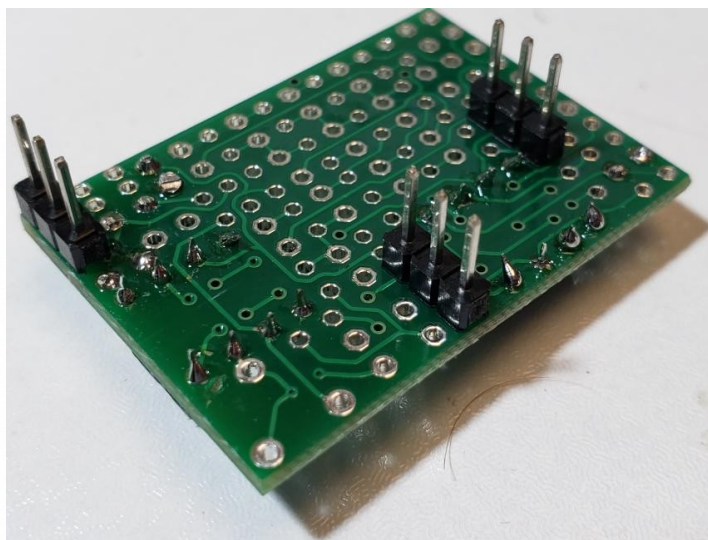
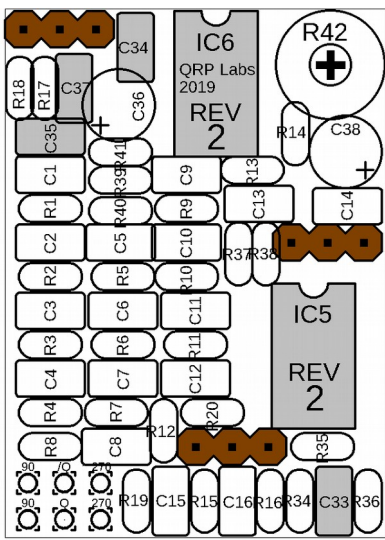

4.5 22nF capacitors

Solder the 16 remaining capacitors, all are 22nF and have the label “223”. These are indicated in red on this diagram. The labels on the silkscreen are very small. So be sure to check the location as indicated on this diagram.

Do not install the 22nF capacitors incorrectly in positions intended for resistors!

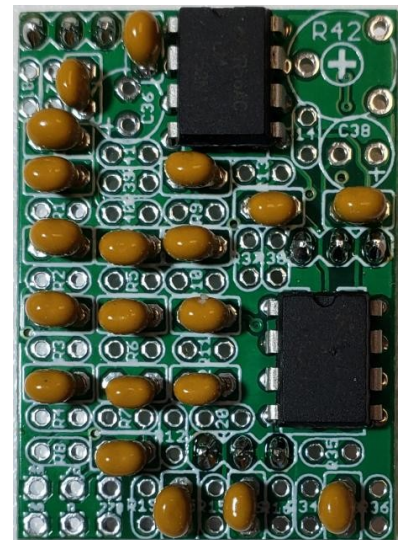
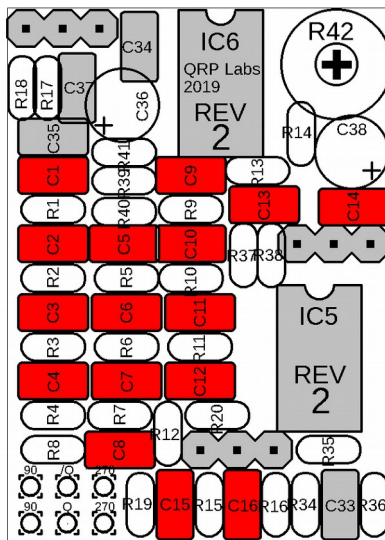

4.6 4.7K resistors

There are four 4.7K resistors, R1, R2, R3 and R4. The colour code is: yellow-purple-black-brown-brown. The location of these resistors is shown on the diagram (below centre) in red.

All of the resistors in this kit are installed vertically. So you need to bend the wires over very resistor as in the picture (below left).

It doesn't matter which way round the resistors are installed but I find the board looks neater if they are all the same way. For example, always solder the body on the left and the wire on the right.

Note that only a very little solder is required. The solder will tend to fall through the hole to the other side of the PCB. So too much solder, will cause a big blob on the other side of the PCB that could cause shorts etc. Therefore only a little solder, soldered quickly with the soldering iron tip, is generally enough.

Trim the excess wire close to the PCB and inspect carefully with the magnifying lens, to check the joints. Check for any shorts to adjacent joints.

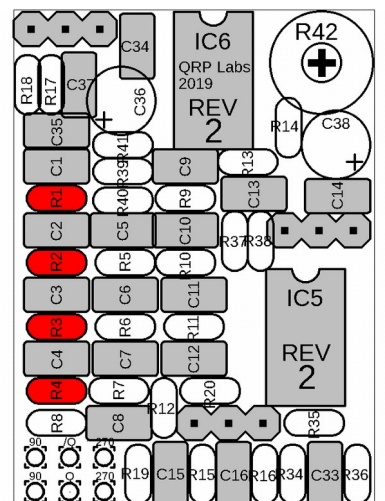

4.7 5.6K resistors

These are R5, R6, R7 and R8. The colour code is: green-blue-black-brown-brown.

The location of these resistors is shown on this diagram in purple.

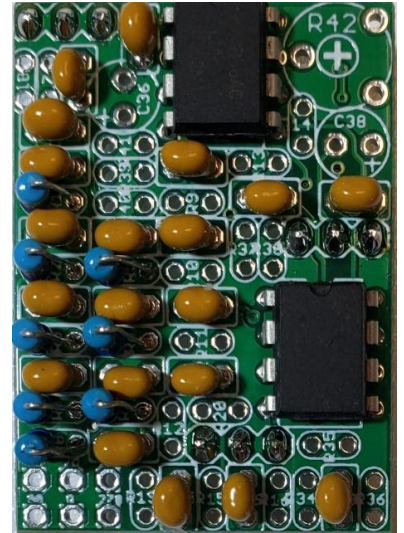
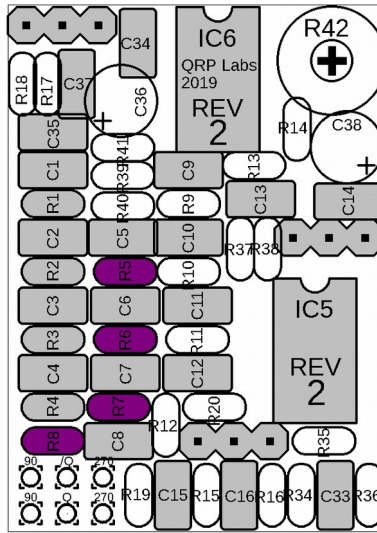

4.8 6.8K resistors

These are R9, R10, R11 and R12. The colour code is: blue-grey-black-brown-brown.

The location of these resistors is shown on this diagram in blue.

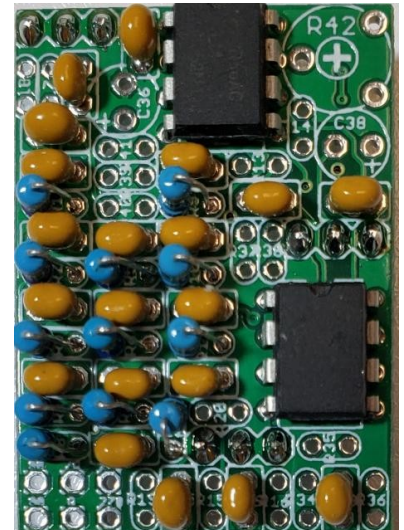
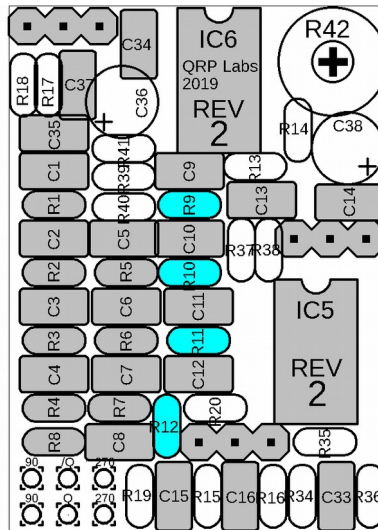

4.9 8.2K resistors

These are R13, R14, R15 and R16. The colour code is: grey-red-black-brown-brown.

The location of these resistors is shown on this diagram in green.

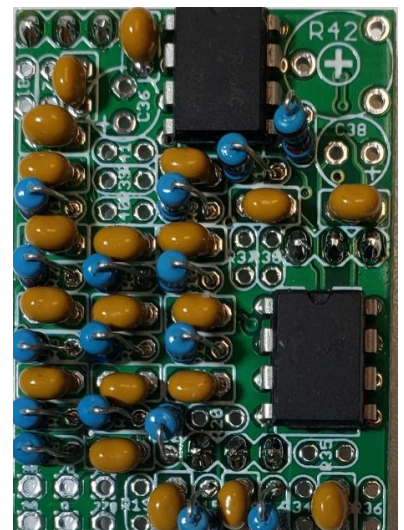
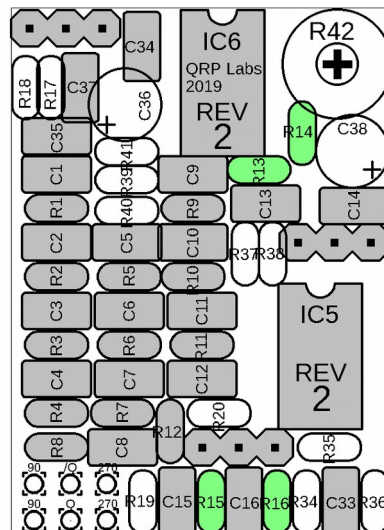

4.10 470-ohm resistors

These are R17, R18, R19 and R20. The colour code is: yellow-purple-black-gold-brown.

The location of these resistors is shown on this diagram in orange.

It's a tight fit at R17 and R18, you can press C37 to the right a little to make them fit.

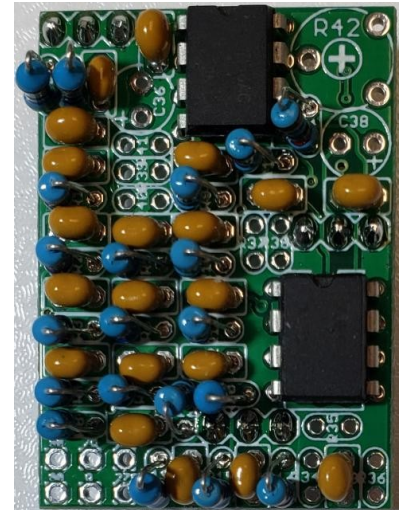
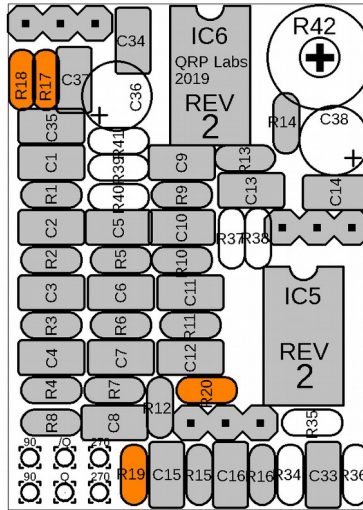

4.11 2.7K resistors

Now install the remaining eight resistors, which are 2.7K. These are R34, R35, R36, R37, R38, R39, R40 and R41. The colour code is: red-purple-black-brown-brown.

The location of these resistors is shown on this diagram in pink.

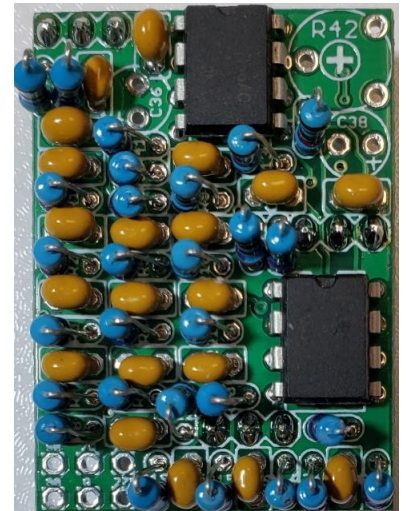
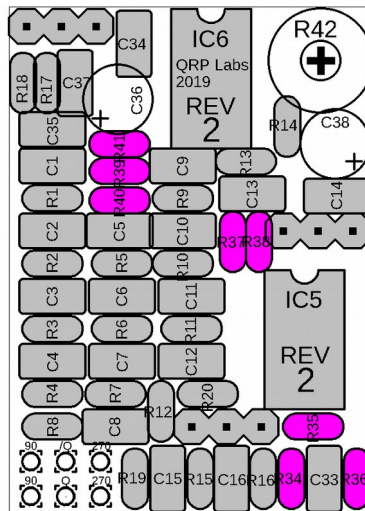

4.12 100K preset potentiometer

Now install the 100K preset potentiometer, R42. Gently press the bent pins into the holes; there is no need to straighten the pins which are designed to click into place inside the holes.

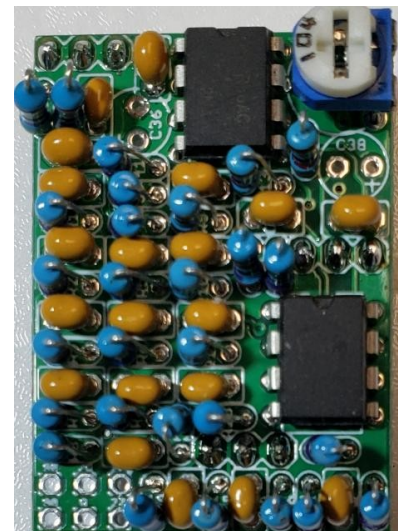
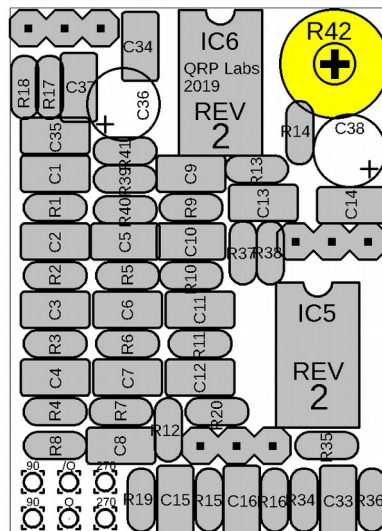

4.13 10uF capacitors

Install the two 10uF capacitors C36 and C38. These are electrolytic capacitors and are polarised. Be sure to install them the correct way around. There is a white stripe on the capacitor body indicating the negative pin. The other pin is the positive pin, and should be aligned with the + on the PCB silkscreen. The positive wire of the capacitor is also a little longer than the negative. So installing the longer wire in the hole marked "+" will work fine too.

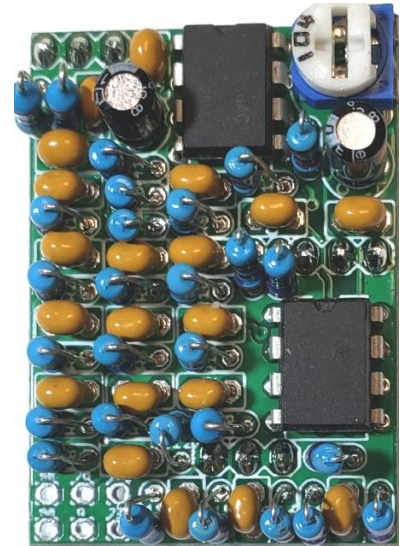
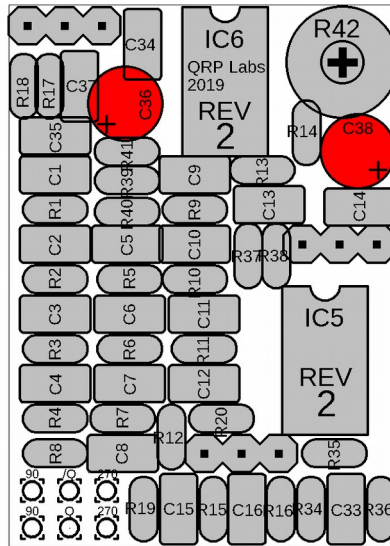

4.14 Header sockets

The final step is to install the three 3-way pin header SOCKETS. These are installed on the main receiver module board, at the locations coloured in red in this diagram. The easiest way to do this, and to ensure everything is correctly aligned, is to plug the sockets over the three 3-way pin headers on the polyphase PCB, then insert the wire ends into the receiver board, and solder.

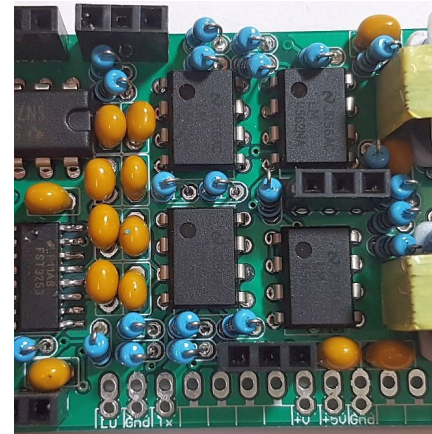
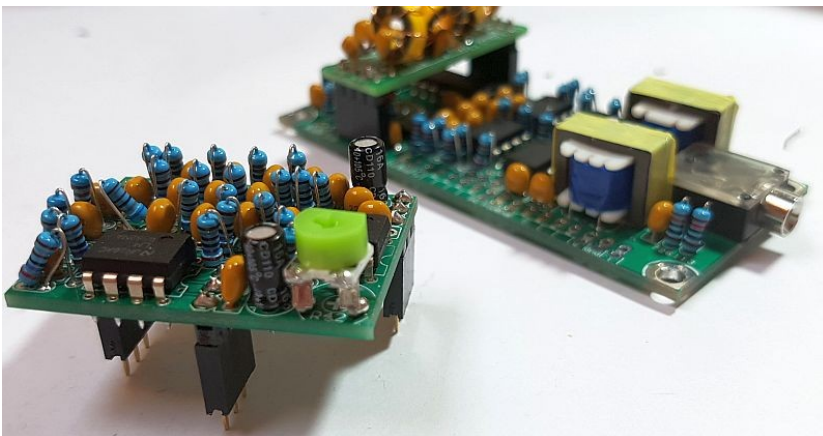
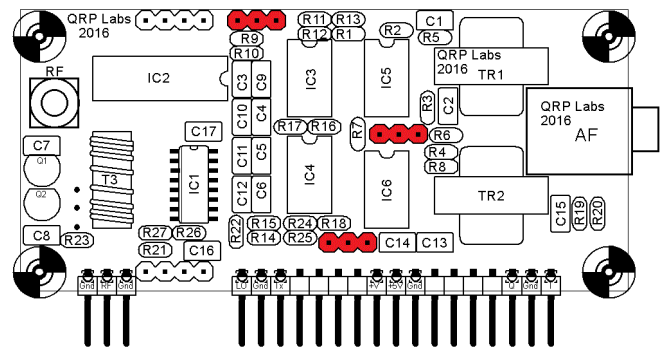

Here's a photo of the completed receiver and polyphase boards, with 30m BPF plugged in.



5. Jumper set-up for USB or LSB

At the bottom left of the PCB (as we have been viewing it) are six pads where two jumper wires must be fitted. These jumper wires will select between USB and LSB. Some possibilities:

- You can fit wire jumpers, made from resistor wire off-cuts, to permanently wire USB or LSB
- You could take shielded (screened) cable wires to a DPDT switch, to allow operator switching between USB and LSB
- Similarly, a relay could be used, under control of a microcontroller for example
- You could fit some pin headers and use the little 2-way header socket jumpers found in some surplus consumer equipment

Whichever way you do it, these connections MUST be made, in order to route the four phases of audio from the Quadrature Sampling Detector on the receiver PCB, to the correct inputs of the polyphase network. The wiring is simple, according to the following diagrams:

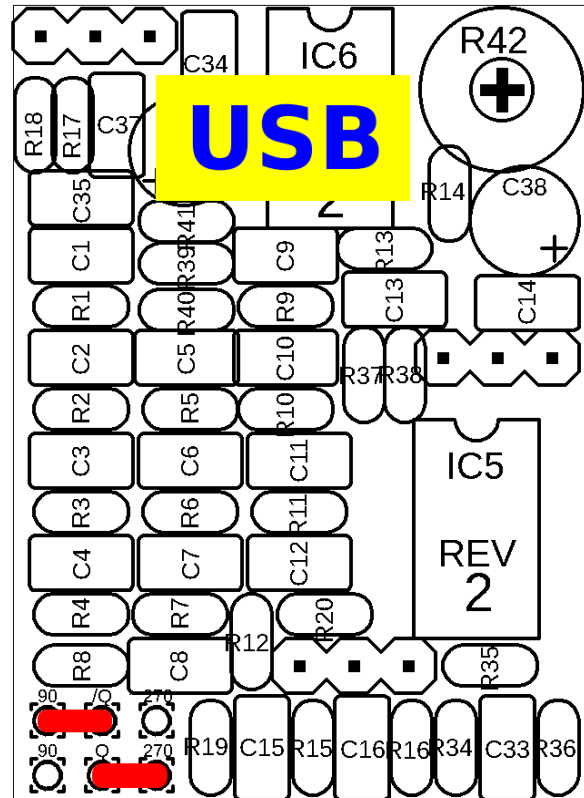
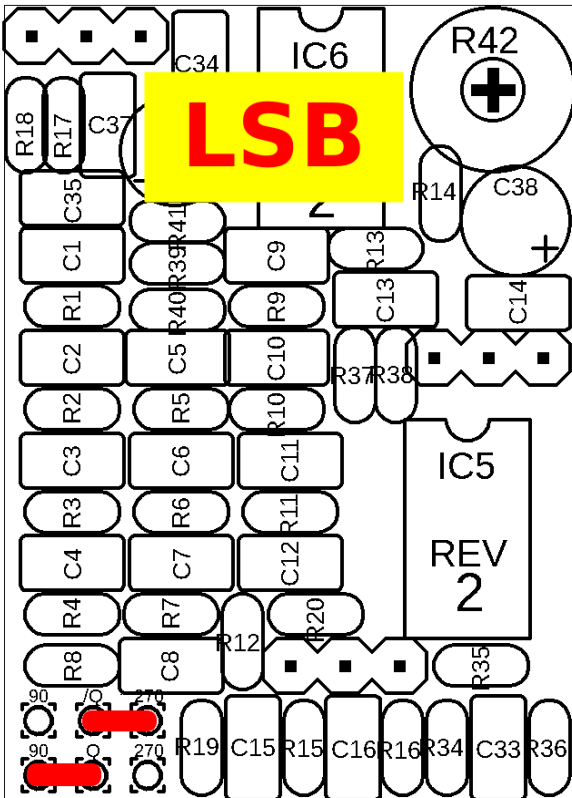

6. Performance measurements

The receiver kit with polyphase network module plugged in was operated with a QRP Labs VFO/SigGen kit as the Local Oscillator and 30m Band Pass Filter. The test signal was a 10.106MHz crystal oscillator using a quad-XOR gate 74HC86. A potential divider made from a 33K resistor and a 47-ohm resistor produces approximately a 3mV signal at the receiver input. The Argo weaksignal QRSS software was used to measure the audio signal amplitude as the VFO was swept through from -3kHz to +3kHz in USB mode.

The first graph shows the amplitude of the output audio signal, against audio frequency, from 0 to 3kHz. The response is pleasingly flat from 500 to 2500Hz.

Frequency response, USB

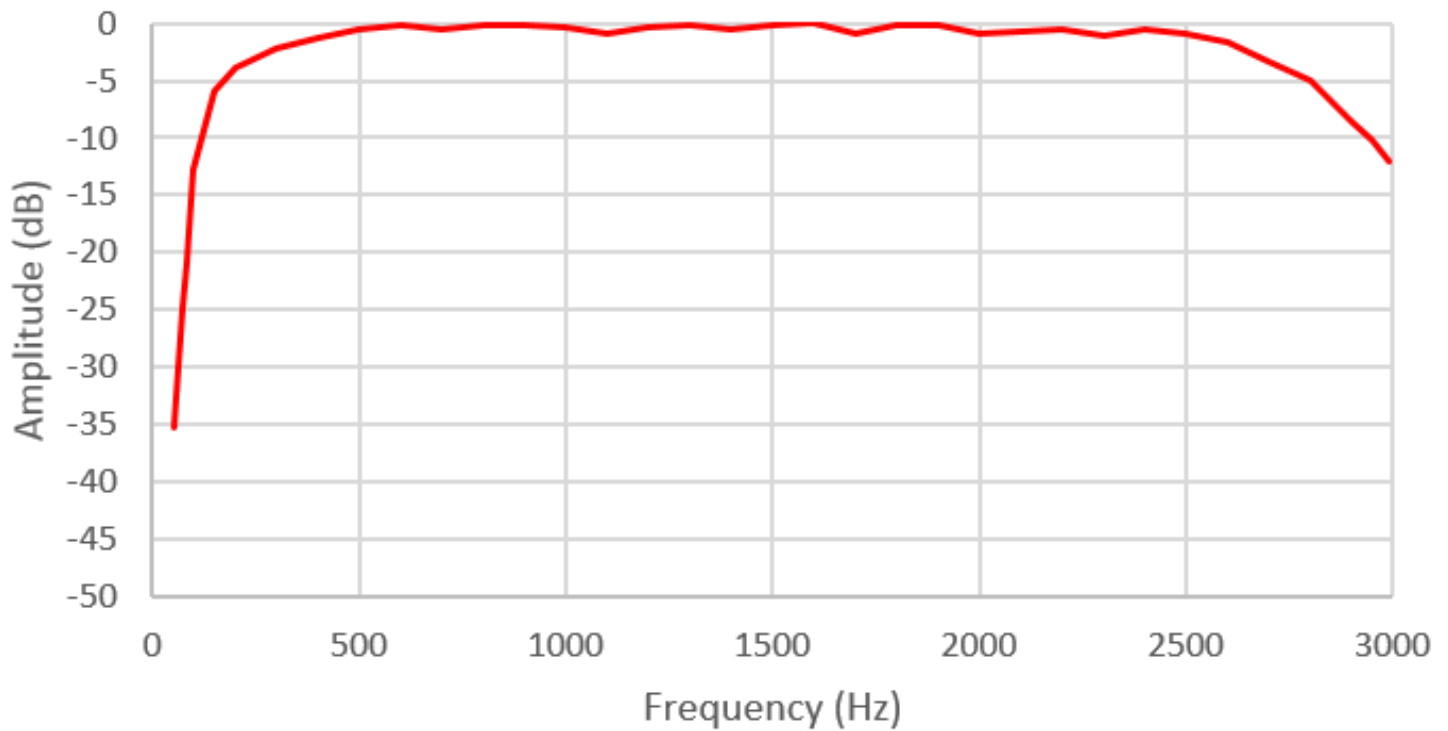

The second graph shows the suppression of the unwanted sideband. For this type of simple polyphase network using inexpensive capacitors (5% tolerance) and resistors (1% tolerance) and with only 4 columns in the network, 40dB of unwanted sideband suppression is a good result. These measurements are considerably better for much of the frequency span, particularly the central part of interest, where QRSS, CW and WSPR operations will be most common.

Unwanted sideband (LSB) suppression

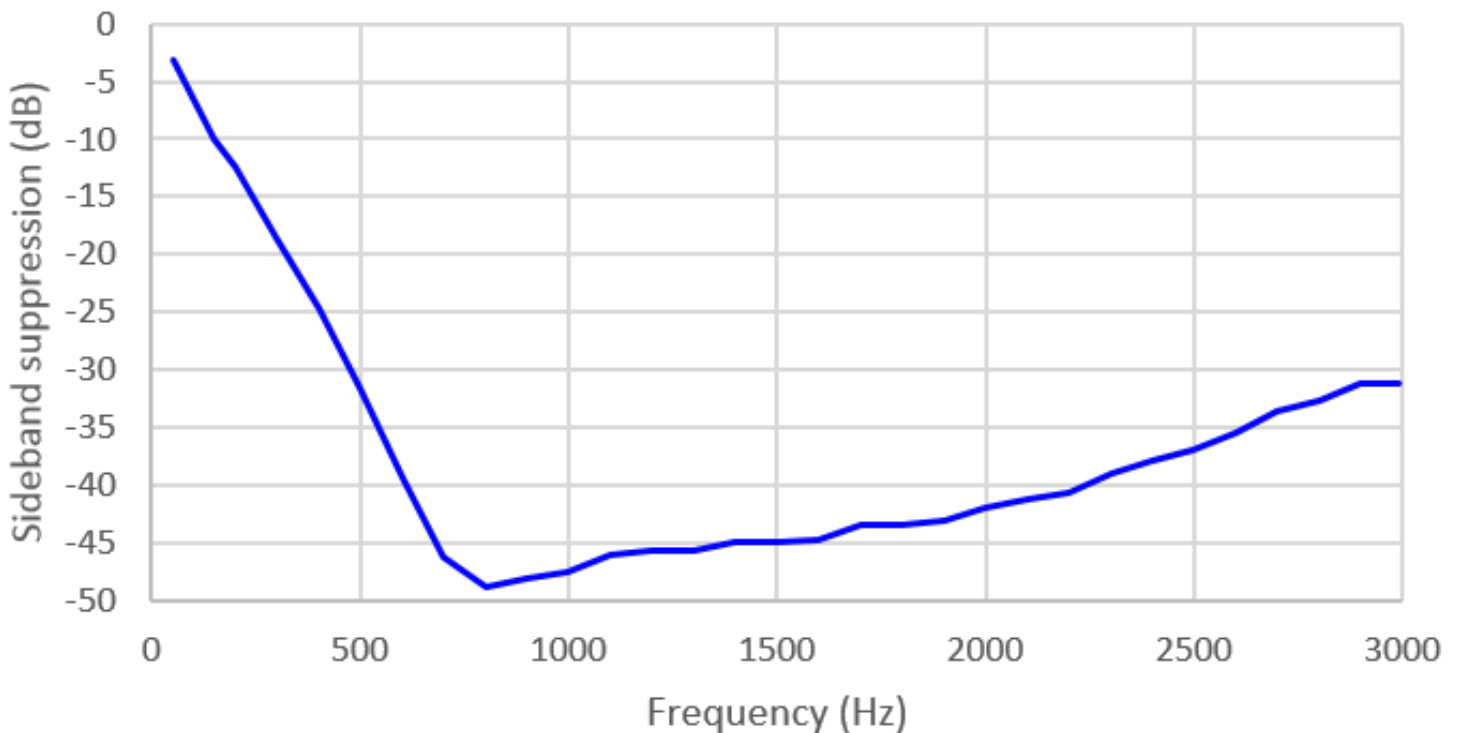

6. Resources

- Please see the kit page <http://qrp-labs.com/polyphase> for information and latest updates.
- There are some more information and links to polyphase reference material at: <http://hanssummers.com/polyphase>

7. Document version history

1 24-Aug-2016

- Initial document version

2 19-Nov-2019

- Document revision for PCB Rev 2: addition of four 470-ohm resistors R17/18/19/20 Initial document version; no more additional steps for the trimmer pot, which now fits perfectly.