QCX-mini 5W CW Transceiver kit assembly instructions

PCB Rev 3

The “QCX-mini”: a single band, high performance 5W CW Transceiver with built-in alignment and test equipment, iambic keyer, WSPR beacon mode, and more...

Designed and produced by QRP Labs, 2017-2020



pictured with:

Palm Radio pico paddle <http://palm-radio.de>

and the XYL's old iPhone's earbuds

Contents

1. Introduction.....	4
2. Parts list.....	5
3. Assembly – general guidelines.....	11
3.1 Inventory parts.....	22
3.2 Wind and install transformer T1.....	23
3.3 Install IC2 socket.....	30
3.4 Install 100nF (0.1uF, “104”) capacitors.....	31
3.5 Install all 470nF, “474” capacitors.....	32
3.6 Install 47nF, “473” capacitor.....	32
3.7 Install capacitors C25 and C26 from Low Pass Filter kit.....	33
3.8 Install capacitors C27 and C28 from Low Pass Filter kit.....	34
3.9 Install capacitor C30.....	35
3.10 Install capacitors C5 and C8.....	36
3.11 Install 1uF, “105” capacitors C21, and C22.....	37
3.12 Install 1N5819 diode.....	38
3.13 Install 20MHz crystal XTAL1.....	39
3.14 Install 27MHz crystal XTAL2 or TCXO option.....	40
3.15 Install 500-ohm multi-turn trimmer potentiometer.....	41
3.16 Install 50K multi-turn trimmer potentiometers.....	42
3.17 Install 470uF capacitors.....	44
3.18 Install 30pF trimmer capacitor C1.....	45
3.19 Install MPS751 transistor Q6.....	46
3.20 Install three BS170 transistors.....	47
3.21 Install 2x3-pin in-circuit programming header.....	48
3.22 Install 2x5 LCD header.....	49
3.23 Install 2x4 UI header.....	50
3.24 Wind and install toroid L4.....	50
3.25 Wind and install toroid L2.....	52
3.26 Wind and install toroids L1 and L3.....	53
3.27 Install 2.1mm power connector.....	54
3.28 Install RF output BNC connector.....	55
3.29 Install 3.5mm stereo jack connectors.....	56
3.30 Break apart inner PCBs of display board.....	57
3.31 Install LCD module.....	59
3.32 Install 2x5-pin male pin header connector.....	60
3.33 Install four 11mm nylon spacers.....	60
3.34 Install 20K trimmer potentiometer R47.....	61
3.35 Install 2x4-pin male header on controls PCB.....	62
3.36 Install rotary encoder.....	64
3.37 Install tactile switch buttons.....	65
3.38 Install gain control potentiometer R36.....	65
3.39 Install 11mm nylon hex spacer.....	66
3.40 Fit Controls PCB to main PCB.....	67
3.41 Install microcontroller.....	68
3.42 Plug together the two boards.....	69
3.43 Connections for basic operation.....	69
3.44 Notes on fault-finding for the QCX-mini.....	70
3.45 Adjustment and alignment.....	71
3.46 Installation in the optional QCX-mini enclosure.....	77

3.47 QCX-mini GPS interface and PTT output.....	80
3.48 QCX-mini CAT port.....	81
4. Circuit design of the QCX-mini.....	82
4.1 Block diagram and summary.....	82
4.2 Circuit diagram.....	82
4.3 Synthesized oscillator.....	85
4.4 Transmit/Receive switch.....	86
4.5 Band Pass, Phase Splitter, QSD and pre-amps.....	87
4.6 90-degree audio phase shift.....	88
4.7 CW filter.....	89
4.8 Audio amplifier.....	89
4.9 Transmit signal routing and PA driver.....	91
4.10 Class-E Power Amplifier.....	92
4.11 Low Pass Filter.....	93
4.12 Key-shaping circuit.....	94
4.13 Microcontroller.....	95
4.14 Optional GPS interface.....	101
4.15 In Circuit Programming (ISP) interface.....	102
4.16 Test Equipment.....	102
4.17 5V voltage regulator.....	104
5. Fault-finding.....	105
5.1 Blank LCD or blocked LCD.....	105
5.2 No back-light at all.....	105
5.3 A row of blocks appears on the top row.....	105
5.4 DC voltage readings.....	106
5.5 RF Power output check.....	108
6. Measurements.....	110
6.1 Equipment.....	110
6.2 Transceiver current consumption.....	110
6.3 Transmitter power output.....	111
6.4 Class-E Power Amplifier drain waveform.....	112
6.5 RF envelope key-shaping.....	112
6.6 Low Pass transmitter harmonic output filter characteristics.....	113
6.7 Band Pass receiver input filter characteristics.....	113
6.8 Quadrature Sampling Detector bandwidth.....	116
6.9 CW Filter response.....	117
6.10 Unwanted sideband rejection.....	118
7. Operation reference "cheat sheet".....	119
8. Resources.....	120
9. Document Revision History.....	120

1. Introduction

Thank you for purchasing this high performance single-band 5W CW transceiver kit, the QCX-mini (for **QRP Labs CW Xcvr mini**). This kit has a long list of features!

Special portable-friendly features:

- Small size: 95 x 63 x 25mm enclosure (plus protrusions)
- Sunlight view-able, 16 x 2 yellow/green LCD screen, back-light can be switched on/off
- Low current consumption (for example 58mA receive current, with 12V supply and display back-light off)
- Low weight, 202 grams
- Sturdy extruded aluminium enclosure
- All-metal BNC short connector, bolted to enclosure

Standard QCX-series features

- Easy to build, two-board design, board with main circuit and connectors, display panel board with LCD; all-controls board-mounted on a press-out sub-board. No wiring, all controls and connectors are board-mounted
- Professional quality double-sided, through-hole plated, silk-screen printed PCBs
- Choice of single band, 160, 80, 60, 40, 30, 20 or 17m
- Approximately 3-5W CW output (depending on supply voltage)
- 7-16V recommended supply voltage
- Class E power amplifier, transistors run cool...
- 7-element Low Pass Filter ensures regulatory compliance
- CW envelope shaping to remove key clicks
- High performance receiver with at least 50dB of unwanted sideband cancellation
- 200Hz CW filter with no ringing
- Si5351A Synthesized VFO with rotary encoder tuning
- Iambic keyer or straight key option included in the firmware
- Simple Digital Signal Processing assisted CW decoder, displayed real-time on-screen
- On-screen S-meter
- On-screen real time clock (not battery backed up)
- Full or semi QSK operation using fast solid-state transmit/receive switching
- Frequency presets, VFO A/B Split operation, RIT, configurable CW Offset
- Configurable sidetone frequency and volume
- Connectors: 2.1mm power barrel connector, 3.5mm keyer jack, 3.5mm stereo earphone jack, 3.5mm stereo jack for PTT, 3.5mm stereo jack for CAT control, BNC RF output
- Built-in test signal generator and alignment tools to complete simple set-up adjustments
- Built-in test equipment: voltmeter, RF power meter, frequency counter, signal generator
- Beacon mode, supporting automatic CW, FSKCW or WSPR operation
- GPS interface for reference frequency calibration and time-keeping (for WSPR beacon)
- CAT control interface
- Optional 50W PA kit
- Optional aluminium extruded cut/drilled/laser-etched black anodized enclosure

No test equipment is required to build, align and operate this CW transceiver. Its innovative self-alignment and self-test features will help and guide you in setting up the transceiver in a few easy steps. The kit also includes a voltmeter, RF power meter, frequency counter and signal generator which can aid in debugging and fault-finding.



We hope you enjoy building and operating this kit! Please read this assembly manual carefully, and follow the instructions step by step in the recommended order. Later in the manual the circuit design is described in detail and we recommend reading and understanding this section too, to get the maximum enjoyment and education from your new radio.

Typical performance measurements are shown in the measurements section. The operation section of the manual describes transceiver, alignment and test equipment operation in detail.

There is a single page reference “cheat sheet” near the end of the manual.

Please check the QCX-mini web page <http://qrp-labs.com/qcxmini> for any updates tips, etc., before starting the assembly.

Please make use of troubleshooting resources at <http://qrp-labs.com/qcxmini> if you have any problems. If you need further help, join the QRP Labs discussion forum on groups.io and post a message about your problem.

2. Parts list

Many components are SMD, pre-soldered to the PCB in the factory. Only through-hole components need to be installed by the constructor. SMD components in the parts list are identified in the Description column and by the text colour being purple.

Resistors

Qty	Value	Description	Component numbers
4	100-ohms	SMD	R5, 6, 8, 9
1	150-ohms	SMD	R41
1	270-ohms	SMD	R50
1	560-ohms	SMD	R48 (on display board)
11	1K	SMD	R3, 4, 19, 26, 37, 45, 49, 54, 55, 62, 63 (R45 on display board)
1	1.2K	SMD	R42
13	3.3K	SMD	R12, 13, 15, 16, 20, 22, 23, 25, 44, 53, 56, 59, 65 (R44 on controls board, R65 on display board)
1	3.9K	SMD	R61
1	4.3K	SMD	R18
1	5.1K	SMD	R11
18	10K	SMD	R1,2,7,10,14,21,34,36,39,40,46,51,52,57,58,64 (R102, 103 on controls board)
2	33K	SMD	R28, 29
2	36K	SMD	R32, 33
2	47K	SMD	R30, 31
4	120K	SMD	R38, 43, 60, 100 (R100 on display board)
1	750K	SMD	R35
1	500-ohm	Multi-turn trimmer potentiometer	R27
2	50K	Multi-turn trimmer	R17, 24

Qty	Value	Description	Component numbers
		potentiometer	
1	5K	Linear potentiometer	R36 (on controls board)
1	22K	Trimmer potentiometer	R47 (on display board)

Capacitors (50V, Multi-layer Ceramic capacitors)

Qty	Value	Description	Component numbers
7	1nF	SMD	C14, 16, 18, 23, 33, 54, 55
2	2.2nF	SMD	C19, 20
1	3.3nF	SMD	C53
6	10nF	SMD	C4, 7, 10, 42 (C101, 102 on controls board)
1	33nF	SMD	C15
1	39nF	SMD	C17
1	47nF	Label "473"	C9
1	47nF	SMD	13
2	0.1uF	Label "104"	C12, 29
14	0.1uF	SMD	C2, 3, 6, 32, 34-36, 39-41, 48-50, 52
5	0.47uF	Label "474"	C11, 43-46
2	1uF	Label "105"	C21, 22
2	2.2uF	SMD	C31, 100 (C100 on display board)
3	10uF	SMD	C37, 38, 51
2	470uF	Electrolytic	C24, 47
1	30pF	Ceramic trimmer capacitor	C1

Band-specific capacitors (50V, 5% capacitors which must be C0G/NP0 type)

Note: depending on band, some capacitors may be left over at the end. This is normal!

160m

Qty	Value	Description	Component numbers
1	22pF	Label "220"	C5
1	100pF	Label "101"	C8
1	820pF	Label "821"	C30
2	820pF	Label "821"	C27, 28
2	2200pF	Label "222"	C25, 26

80m

Qty	Value	Description	Component numbers
1	39pF	Label "390"	C5
1	22pF	Label "220"	C8
1	180pF	Label "181"	C30
2	470pF	Label "471"	C27, 28
2	1200pF	Label "122"	C25, 26

60m (C30 is two capacitors in parallel)

Qty	Value	Description	Component numbers
1	39pF	Label "390"	C5
1	22pF	Label "220"	C8
1	30pF or 33pF	Label "300" or "330"	C30 (C30 is two capacitors in parallel)
1	56pF	Label "560"	C30 (C30 is two capacitors in parallel)
2	680pF	Label "681"	C27, 28
2	1200pF	Label "122"	C25, 26

40m (no C8 capacitor)

Qty	Value	Description	Component numbers
1	39pF	Label "390"	C5
1	56pF	Label "560"	C30
2	270pF	Label "271"	C27, 28
2	680pF	Label "681"	C25, 26

30m (no C8 capacitor)

Qty	Value	Description	Component numbers
1	22pF	Label "220"	C5
1	30pF or 33pF	Label "300" or "330"	C30
2	270pF	Label "271"	C27, 28
2	560pF	Label "561"	C25, 26

20m (no C5 or C8 capacitors)

Qty	Value	Description	Component numbers
1	30pF or 33pF	Label "300" or "330"	C30
2	180pF	Label "181"	C27, 28
2	390pF	Label "391"	C25, 26

17m (no C5 or C8 capacitors)

Qty	Value	Description	Component numbers
1	30pF or 33pF	Label "300" or "330"	C30
2	100pF	Label "101"	C27, 28
2	270pF	Label "271"	C25, 26

Semiconductors

Qty	Description	Component numbers
5	SMD	D1, 2, 4, 5, 6
1	1N5819 diode	D33 (was previously D3)
1	SMD: Si5351A, 10-pin MSOP	IC1
1	ATmega328, microcontroller	IC2
1	SMD: 74ACT00N	IC3
1	SMD: FST3253	IC4
1	SMD: LM4562 dual op-amp	IC5
4	SMD: TLC2262 dual op-amp	IC6-9
1	SMD: OPA2277 dual op-amp	IC10 (NE5532 may be used)
1	SMD: AMS1117-5.0, 5V	IC11
4	SMD: BSS123 MOSFET	Q4, 5, 7, 100 (Q100 on display board)
3	BS170: TO92 MOSFET	Q1-3
1	MPS751 TO92 transistor	Q6

Inductors

Qty	Description	Component numbers
2	SMD: 47uH inductor	L5, 6

Band-specific inductors

160m

Qty	Value	Description	Component numbers
1	4.0uH	31 turns on T37-2 core (red)	L1
1	6.4uH	40 turns on T37-2 core (red)	L2
1	3.9uH	30 turns on T37-2 core (red)	L3
1	1.4uH	19 turns on T37-2 core (red)	L4
1		3+3+3+10 turns, FT50-43 (black)	T1

80m

Qty	Value	Description	Component numbers
2	2.4uH	25 turns on T37-2 core (red)	L1, L3
1	3.0uH	27 turns on T37-2 core (red)	L2
1	2.3uH	24 turns on T37-2 core (red)	L4
1		5+5+5+68 turns, T50-2 core (red)	T1

60m

Qty	Value	Description	Component numbers
2	2.1uH	23 turns on T37-2 core (red)	L1, L3
1	2.3uH	24 turns on T37-2 core (red)	L2
1	2.3uH	24 turns on T37-2 core (red)	L4
1		5+5+5+46 turns, T50-2 core (red)	T1

40m

Qty	Value	Description	Component numbers
2	1.4uH	21 turns on T37-6 core (yellow)	L1, L3
1	1.7uH	24 turns on T37-6 core (yellow)	L2
1	1.0uH	16 turns on T37-2 core (red)	L4
1		5+5+5+38 turns, T50-2 core (red)	T1

30m

Qty	Value	Description	Component numbers
2	1.1uH	19 turns on T37-6 core (yellow)	L1, L3
1	1.3uH	20 turns on T37-6 core (yellow)	L2
1	0.78uH	14 turns on T37-2 core (red)	L4
1		4+4+4+30 turns, T50-2 core (red)	T1

20m

Qty	Value	Description	Component numbers
2	0.77uH	16 turns on T37-6 core (yellow)	L1, L3
1	0.90uH	17 turns on T37-6 core (yellow)	L2
1	0.40uH	10 turns on T37-2 core (red)	L4
1		3+3+3+30 turns, T50-2 core (red)	T1

17m

Qty	Value	Description	Component numbers
2	0.55uH	13 turns on T37-6 core (yellow)	L1, L3
1	0.67uH	15 turns on T37-6 core (yellow)	L2
1	0.32uH	9 turns on T37-2 core (red)	L4
1		3+3+3+22 turns, T50-2 core (red)	T1

Miscellaneous

Qty	Value	Description	Component numbers
1	2x3-pin	Male pin header	
1	2.1mm	2.1mm DC Power barrel connector	
4	3.5mm	3.5mm stereo jack socket	
1	BNC	BNC connector socket	
1	2x5-pin	Female pin header socket	
1	2x5-pin	Male pin header socket	
1	2x4-pin	Female pin header socket	
1	2x4-pin	Male pin header socket	
2	6x6x8	6x6x8mm tactile switch button	S2, 3
1		Rotary encoder with shaft button	SW1
1	1602	HD44780 LCD 1602, yellow/green back-light	
1	20MHz	HC49/4H quartz crystal	XTAL1
1	27MHz	HC49/4H quartz crystal	XTAL2
1	PCB	Main PCB	
1	PCB	Display PCB panel	
2	Knob	Knob to fit rotary encoder and R36	
1	200cm	0.33mm diameter wire (AWG #28)	
1	M3 10mm	Steel 10mm long M3 screw	
1	M3	Steel M3 nut	
1	M3 12mm	Steel 12mm diameter M3 washer	
5	11mm	Nylon M3 hex spacer	
10	6mm	Nylon M3 6mm screw	
2	6mm	Nylon or steel M3 6mm screw	
2		Nylon or steel M3 nut	

3. Assembly – general guidelines

Assembly of this kit is quite straightforward. But there are quite a lot of components. So please keep them methodically in trays or some convenient storage boxes, and be careful not to misplace any. The usual kit-building recommendations apply: work in a well-lit area, with peace and quiet to concentrate. **The IC (chips) and some of the other semiconductors in the kit are sensitive to static discharge. Therefore, observe Electrostatic discharge (ESD) precautions.** And I say it again: **FOLLOW THE INSTRUCTIONS!!** Don't try to be a hero and do it without instructions!

A jeweler's loupe is really useful for inspecting small components and soldered joints. You'll need a fine-tipped soldering iron too. It is good to get into the habit of inspecting every joint with the magnifying glass or jeweler's loupe (like this one I use), right after soldering. This way you can easily identify any dry joints or solder bridges, before they become a problem later on when you are trying to test the project.



You could also take photos with a mobile phone, and use the phone's zoom features to view the board in detail.

Triple check every component value and location BEFORE soldering the component!

It is easy to put component leads into the wrong holes, so check, check and check again! It is difficult to de-solder and replace components, so it is much better to get them correctly installed the first time. In the event of a mistake, it is always best to detect and correct any errors as early as possible (immediately after soldering the incorrect component). **Again, a reminder: removing a component and re-installing it later is often very difficult!**

Please refer to the layout diagram and PCB tracks diagrams below, and follow the steps very carefully.

Assembly steps will be in the order of smallest to largest components. I generally follow the order semiconductors, capacitors, resistors and finally all other (generally larger) components. It is probably unnecessarily thorough and complex to build the radio one stage at a time and test each stage one by one... I recommend just install everything then power up.

As per standard QRP Labs practice, the ATmega328P microcontroller has a 28-pin DIP socket in case you may wish to subsequently replace it for firmware upgrades etc. Many of the components in this kit are in surface mount packages (SMD) and these are already soldered to the PCB for you, at the factory. All other components used are all leaded through-hole packages, and all are installed on the top side of the PCB except where otherwise noted.

Use of a good quality soldering iron and solder is highly recommended for best results!

SPECIAL CARE tips by Hans G0UPL

The QCX-mini kit is very compact. It requires a higher degree of precision than many other QRP Labs kits, if you are intending to install it in the optional enclosure. It's not more difficult. It just requires a bit more care. Pay careful attention to the following points, throughout the assembly.

1. Board inspection

Even the SMD assembly line is not perfect and mistakes can occur. I recommend a careful visual inspection before commencing assembly, with a jeweler's loupe or other optical magnification aid. Look for any solder bridges between IC pins, or solder splashes which may cause short-circuits.

2. Soldering

In the QCX-mini kit, there are SMD components installed on BOTH sides of the PCB. When soldering through-hole component leads, you will often be soldering a joint that is very close to nearby SMD components. In this case, angle the PCB and soldering iron so that you are approaching the joint, and touching and heating the joint, from the opposite direction to the SMD component, to avoid heating it and removing it.

In the photograph below, SMD capacitor C4 is very close to the component leads being soldered; I approached the joint from the right-hand side, away from the SMD component, and successfully soldered the joint without coming anywhere near C4. I successfully assembled this PCB even though my soldering iron tip is an enormous 3mm chisel-bit.



3. Mistakes

If you do make a mistake and end up with a solder bridge somewhere, desoldering braid (a.k.a. solder wick) can really help clean this up, it is well worth having some of this in the workshop. If you have no braid to hand, you can even use the braid from a piece of old coax or shielded cable, perhaps soaked in flux first if you have some.

4. Component lead offcuts

When cutting wire-offcuts, take great care not to damage any nearby SMD components with the wire cutter!

At the same time, you need to cut quite close to the PCB to keep the remaining wire lengths short, to avoid any wires short-circuiting with the base of the aluminium enclosure.

In this kit, you must KEEP all the component lead off-cuts! Yes, I know, it's fun when you cut them with the wire-cutter to hear them pinging around the room somewhere, and even more fun when your XYL finds them embedded in the carpet somewhere else in the house, and nothing quite beats the entertainment value of when she steps on one and it is embedded in the sole of her foot... ah yes, oh, the baby keeps waking up all night, EVEN more often than he would normally anyway. What? Who put that 2cm piece of wire offcut in his nappy (a.k.a. diaper), that can't have been very comfortable. Ooops.



Yes, fun fun! BUT, in this assembly you actually have to KEEP the component wire offcuts because you are going to use them later in the assembly, for connecting the LCD module to the display board, and for connecting some controls to the controls board.

So please read this and keep those off-cuts safely.

5. Fuses and current-limited supplies

Generally an in-line fuse and/or a current limited supply is a good thing. A QCX-mini should not draw more than 600-700mA and if it does, you may have a problem somewhere – and a fuse or other current limiting could save something from burning up.

5. PRECISION

I can't emphasize this enough: this board is compact, and the fit in the optional enclosure is precise with low tolerance for error. The following is essential:

- In general, the holes in the PCB are larger than the corresponding component leads/pins. Try to align each component centrally and squarely, where there is movement range.
- All connectors and controls need to be seated flush on the PCB, orientated square to the PCB, and precisely aligned as described in the corresponding assembly manual steps.
- All components need to be installed seated fully on the PCB, such as electrolytic capacitors and the trimmer resistors, because in many cases even an extra fraction of a mm height can cause the boards to not fit together properly.
- Follow all assembly steps carefully and precisely. Pay particular attention to any description involving component orientation, such as cutting off the feet of the trimmer potentiometers,

The following diagrams show the PCB layout and track diagrams of the display and main PCBs of the QCX-mini kit (red track = top side; blue track = bottom side; there are no hidden layers).

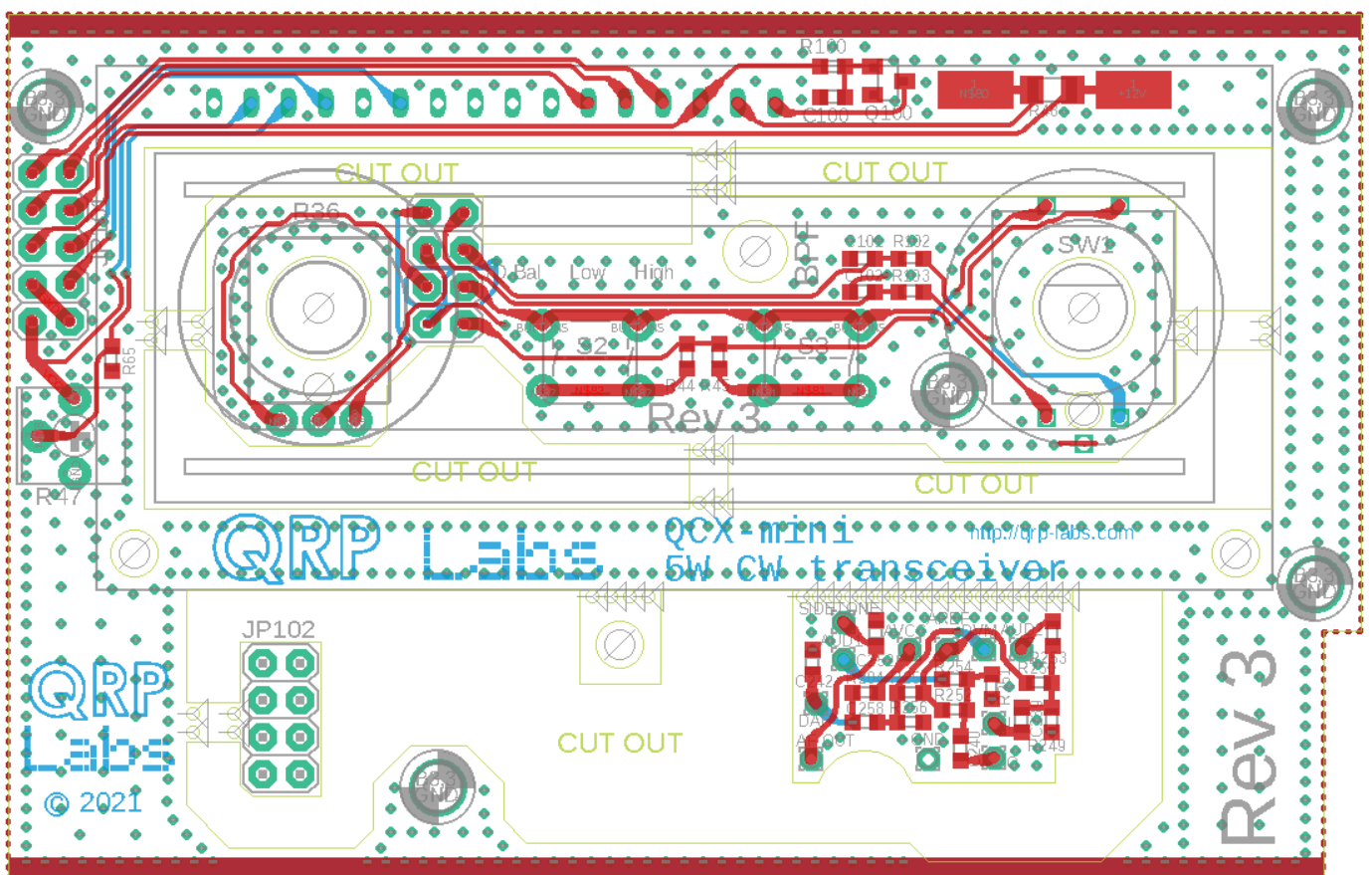
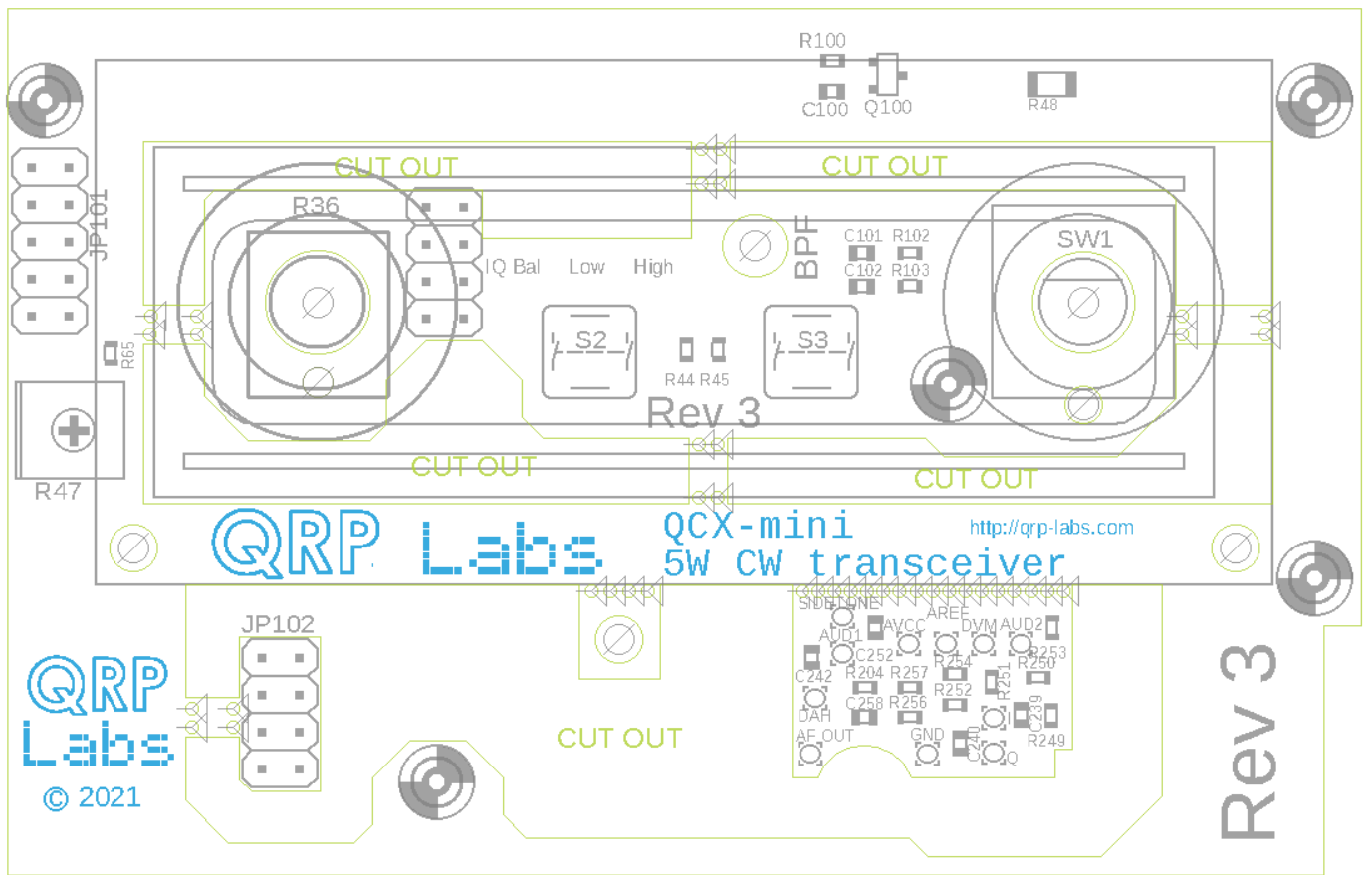

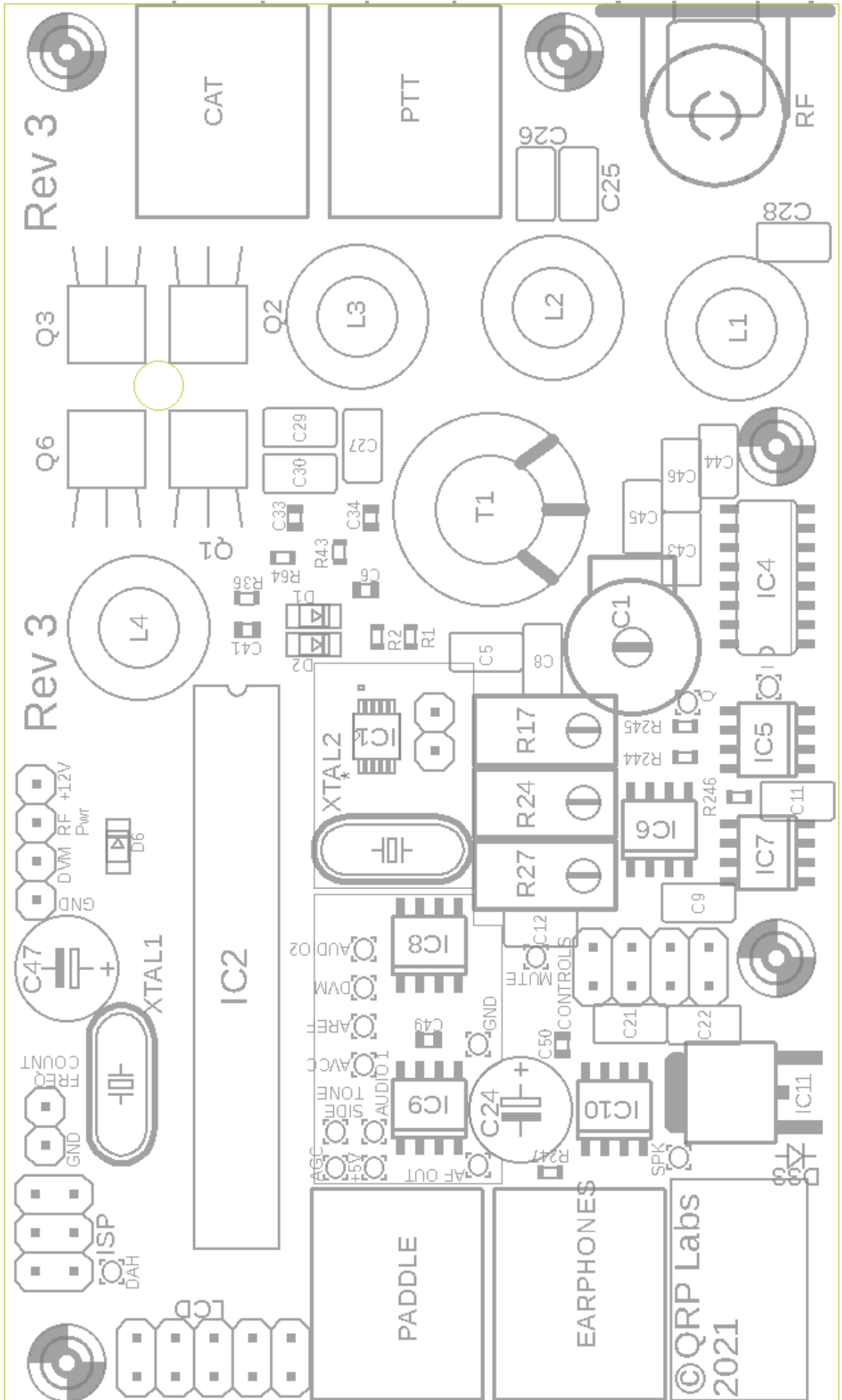

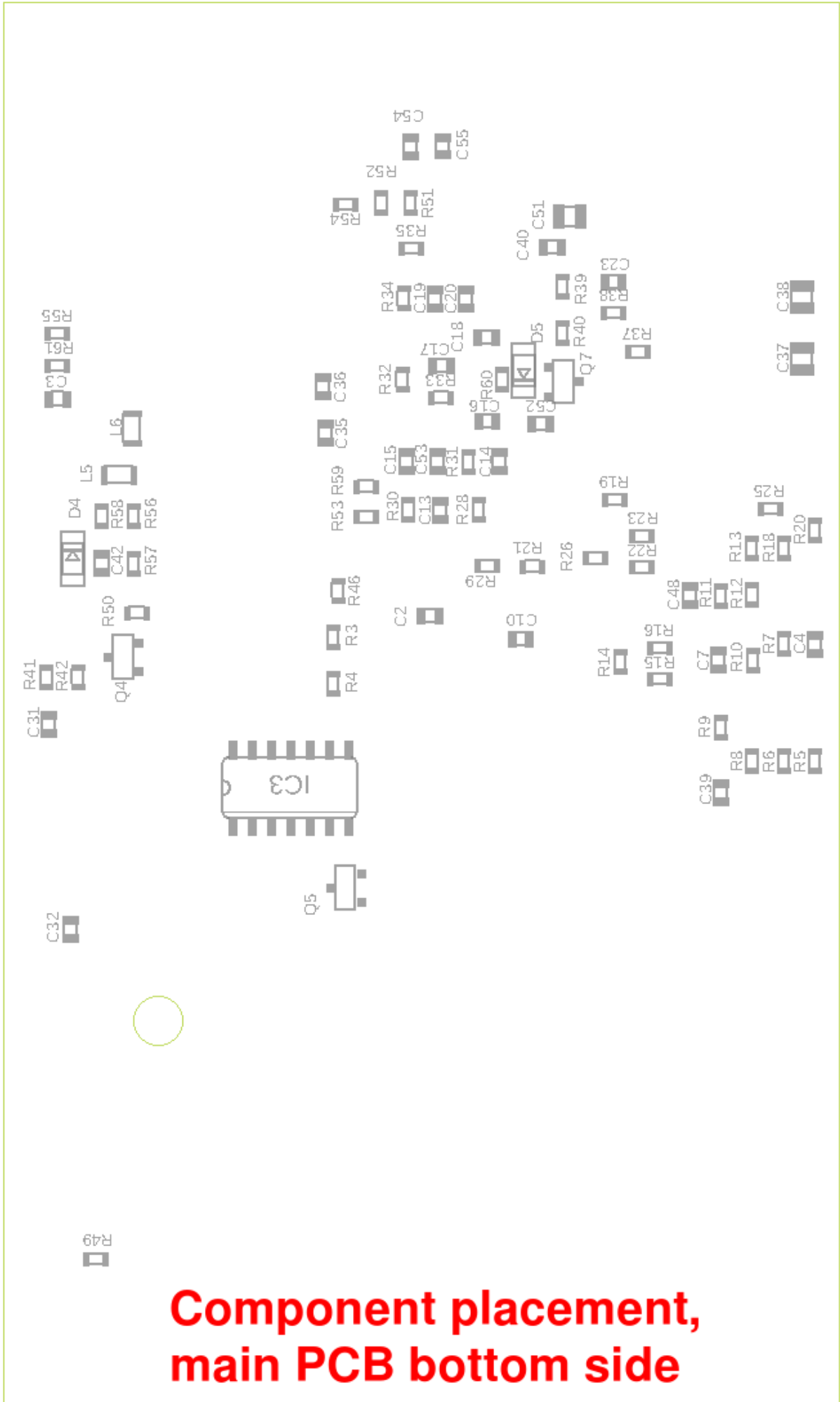

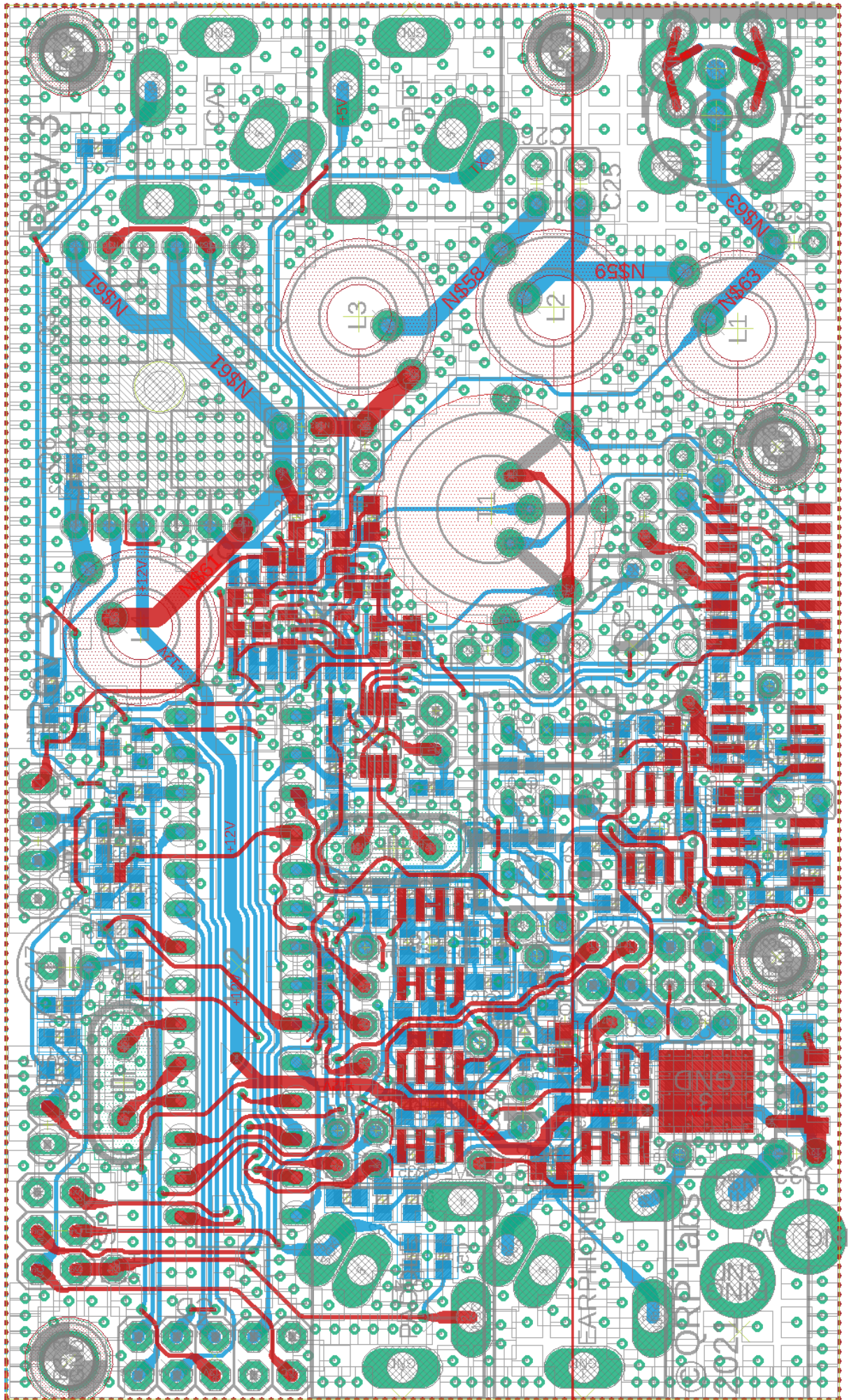

Tracks shown in BLUE are on the bottom layer. Tracks shown in RED are on the top layer. There are only two layers (nothing is hidden in the middle). Not shown in this diagram are the extensive ground-planes, on both sides of the board. Practically everything on both layers that isn't a RED or BLUE track, is ground-plane! The two ground-planes are connected at frequent intervals (not more than 0.1-inches) by vias. This is the kind of layout I have done previously for a quad-band GSM device operating at up to 1900MHz... it is probably overkill in an HF transceiver... but if you can, why not! I used to say often that you can never have too much supply line filtering and decoupling, and never have too much shielding. Both these statements don't apply so conveniently to kits as they do to homebrew projects. In a kit every decoupling capacitor has a cost in both money and PCB area (which also means more money). Shielding is even more difficult and expensive. So shielding and decoupling should be applied where needed only! But ground-plane – well that's another story. It's free, and without drawbacks – so why not, let's just put it everywhere.

All components on the main PCB are installed on the top (component side) of the PCB and soldered on the bottom (solder side) of the PCB. On the display PCB the 2x5-pin header connector is installed on the reverse side so refer to the assembly manual steps very carefully.

Take care when installing integrated circuits. All through-hole integrated circuits are supplied by the manufacturers with their pins bent a little wide. You need to carefully bend the rows of pins of the ATmega328 microcontroller together a little, in order to fit it into the 28-pin IC socket.

The band-specific Low Pass Filter (LPF) parts are supplied in a separate LPF kit bag.

In the construction for some bands, not all of the capacitors supplied in the kit are used. Do not be alarmed if you have a few components left over at the end!

Wind the L1-3 inductors with the enameled copper wire supplied in the LPF kit bag. Wind the other inductors (L4 and transformer T1) using the wire supplied in the main kit bag.

The component colour coding of the layout diagram at every step of the assembly instructions is as follows (kind of: components past, present and future):

- Components shaded grey have already been installed
- Components shaded red are the ones being installed in the current assembly step
- Components shaded white are the ones which have not yet been installed

The following photographs show the final assembly. You can keep these photographs in mind when assembling the kit, they will give you some idea of how the kit fits together and help avoid assembly errors.

Main board:



Display board:



Controls board:

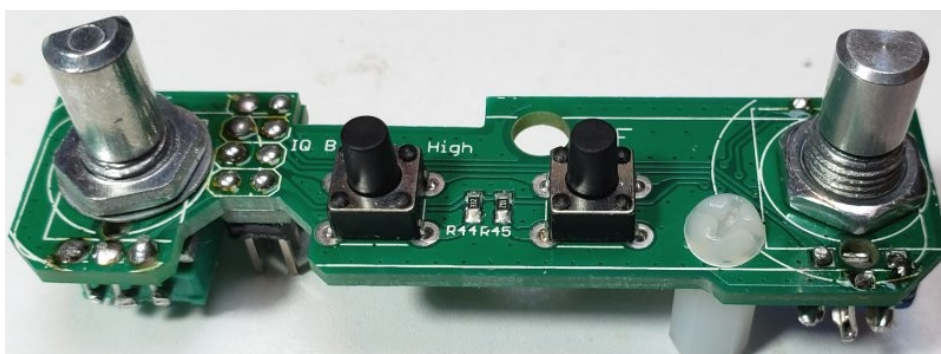

There are two PCB panels supplied in the kit, each is packaged in a separate static-proof zip-lock bag. The main PCB has SMD components soldered to both sides; handle it with care to avoid dislodging any components. The display PCB also has several SMD components installed.

The display PCB panel has cut-out areas, which are used to create additional PCBs used in the design. These additional PCBs will be broken off the display PCB along lines of drill-holes.

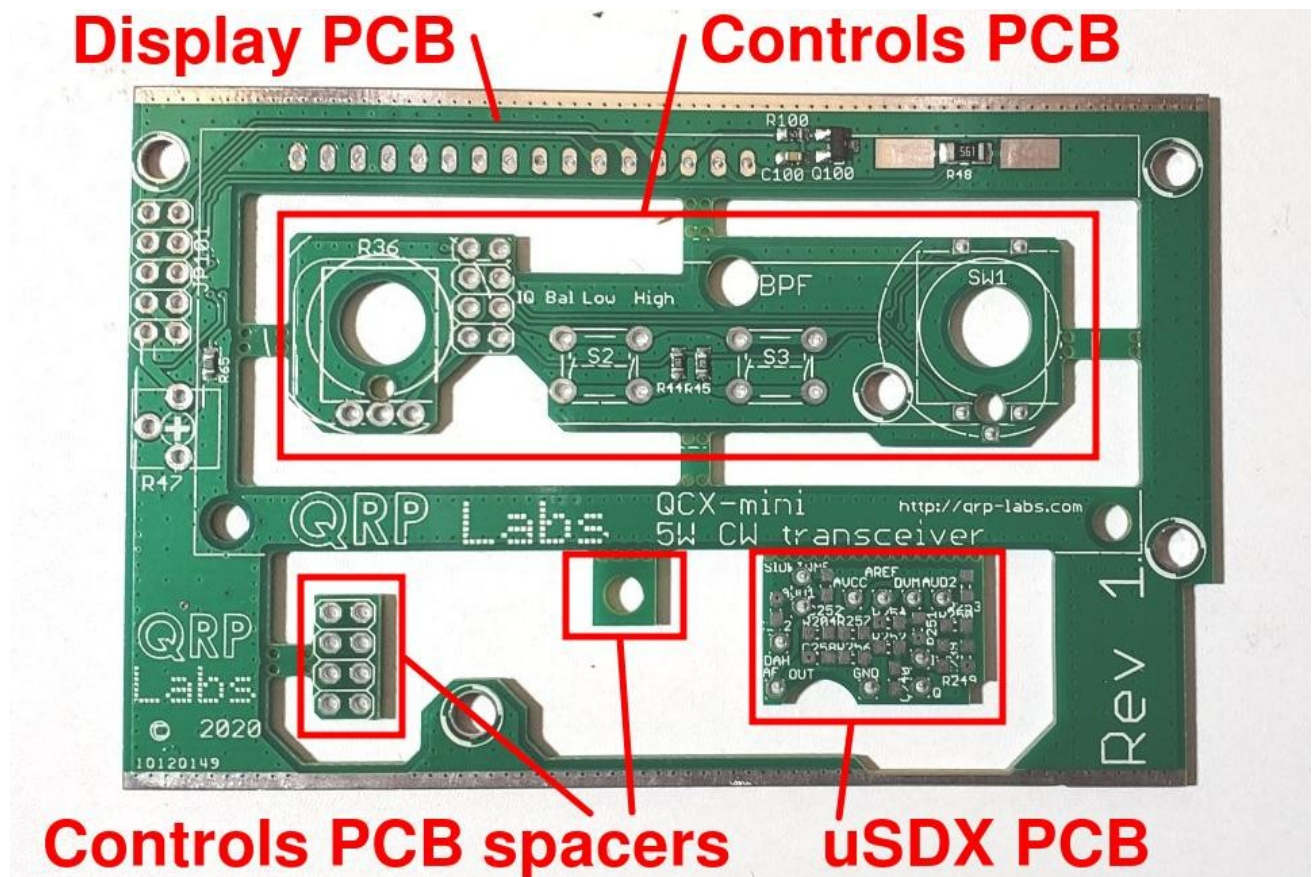

The “Controls PCB” connects to the main PCB using a 2x4-pin header connector, and is fixed with a hex spacer and screws. This board holds the gain control and rotary encoder, as well as the two push-button switches.

The controls PCB needs to be slightly higher relative to the main board than the display PCB, this is accomplished using two small spacer PCBs, one which fits on the 2x4-pin header, and one which fits on the hex spacer; together these elevate the controls PCB by 1.6mm (one standard FR4 PCB thickness) above the height of the display PCB.

The uSDX PCB is a small daughtercard that can be installed on the main PCB and provides an easy conversion of the QCX-mini to the uSDX SSB SDR transceiver. Components are not supplied to populate this PCB. The conversion is supported by the uSDX group <https://groups.io/g/ucx> and there is no technical support from QRP Labs. The daughtercard is supplied as-is, to assist this conversion for experimenters who wish to try uSDX.

1



The PCBs may come with a surplus strip of material along one or more edges; this is used during the manufacturing processes to panelize PCBs on a larger panel of blank FR4. If this is the case, just gently snap off the excess strip of board.

2

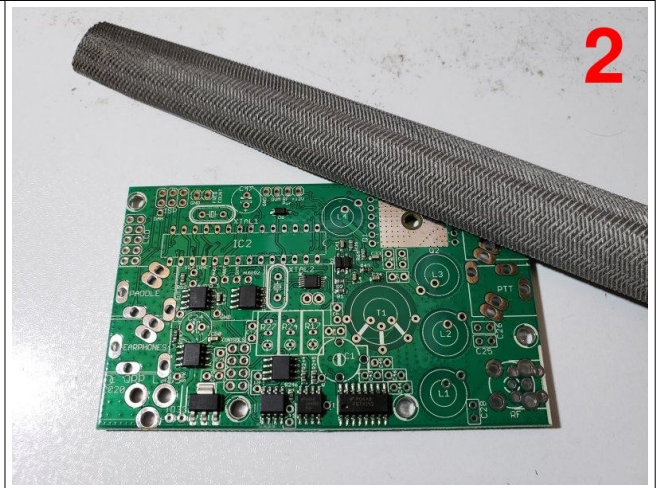

It's also important to gently file away any rough edges of the PCB from where it has been snapped out of the larger panel.

3.1 Inventory parts

Refer to parts list in section 2. The following photographs are to aid component identification. Several components are missing from this photo. So for a complete inventory refer to the parts list, remembering to check the band-specific components for your band.

Remember that the main kit bag contains several smaller clear plastic zip-lock bags, and components are spread through the different bags with no apparent rules or reason.

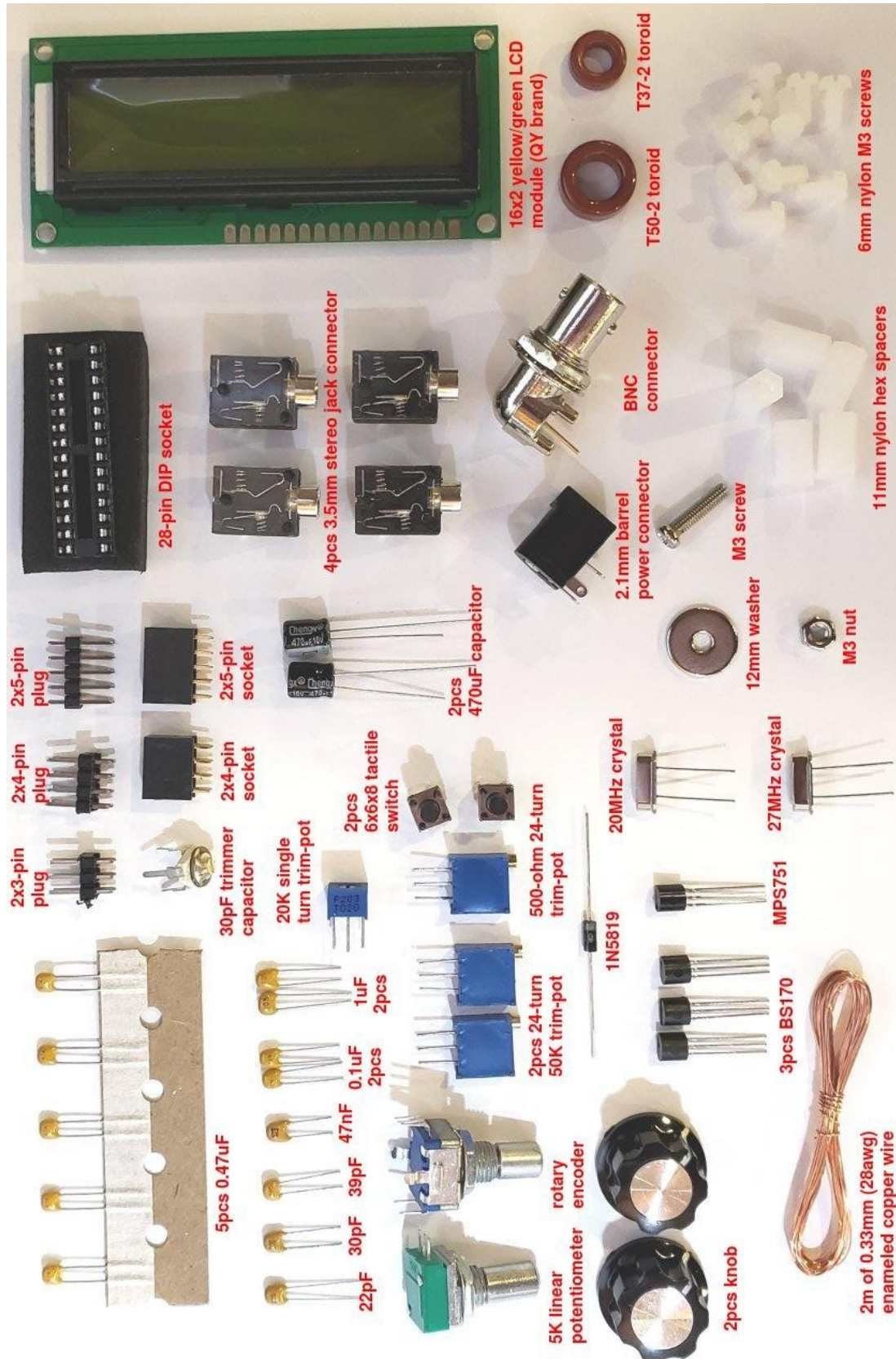

3.2 Wind and install transformer T1

This is the only really tricky piece of the assembly: the receiver input transformer T1. Follow these instructions carefully, it is tricky but quite feasible if you go step by step.

This is the FIRST step because it is easiest to do the installation when there are no other components nearby.

In the end, you are going to end up with an installed transformer which hopefully looks something like the photo (right, shows 40m version).

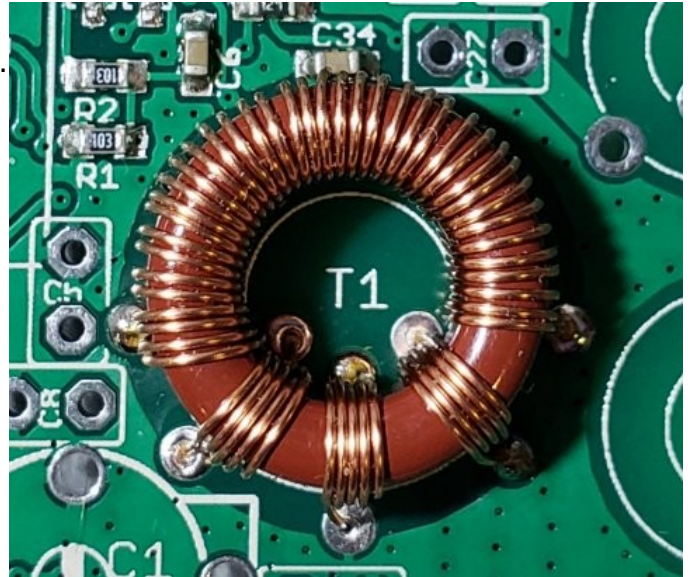

This transformer has FOUR windings.

Three identical short windings, and one long winding. There are therefore eight wire ends, which must all be soldered into the correct holes on the PCB, and with the enamel properly removed.

Here are two diagrams which enumerate each of the windings, wire endings and holes on the PCB, on both the layout diagram and on the circuit (schematic) diagram. It should help to explain diagrammatically which wires must go where.

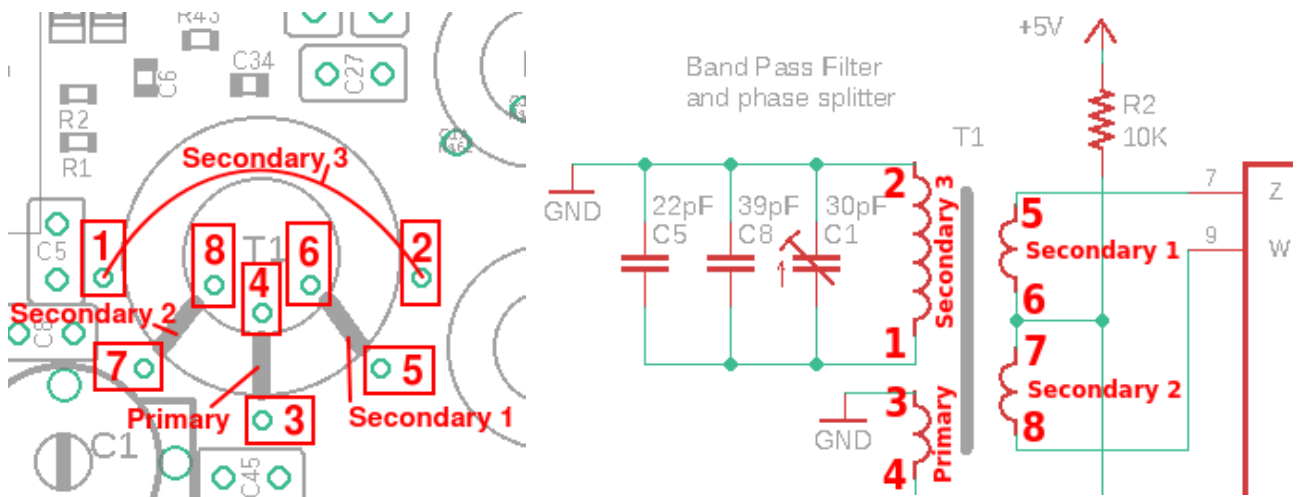

On the following page is a diagram hand-drawn by Ed WA4MZS (thanks Ed!) which may also clarify the construction and installation of T1.

The four windings on T1 must all be in the same “sense”. There are two ways to wind toroids. You might call them left-handed and right-handed; clockwise and counter-clockwise; whether the wire goes through the toroid from top to bottom, or from bottom to top. Whatever you call it, all the four windings have to be the same, to be sure to get the phasing to the quadrature sampling detector correct.

(Technically, only the secondary 1 and secondary 2 have to be in the same sense; but it is simpler to just wind everything the same way).

BAND	PRI	S1	S2	S3
80m	5T	5T	5T	68T
60m	5T	5T	5T	46T
40m	5T	5T	5T	38T
30m	4T	4T	4T	30T
20m	3T	3T	3T	30T
17m	3T	3T	3T	22T

CORE = T50-2

WIND w/ # 28 ENAM.
(0.33 mm)

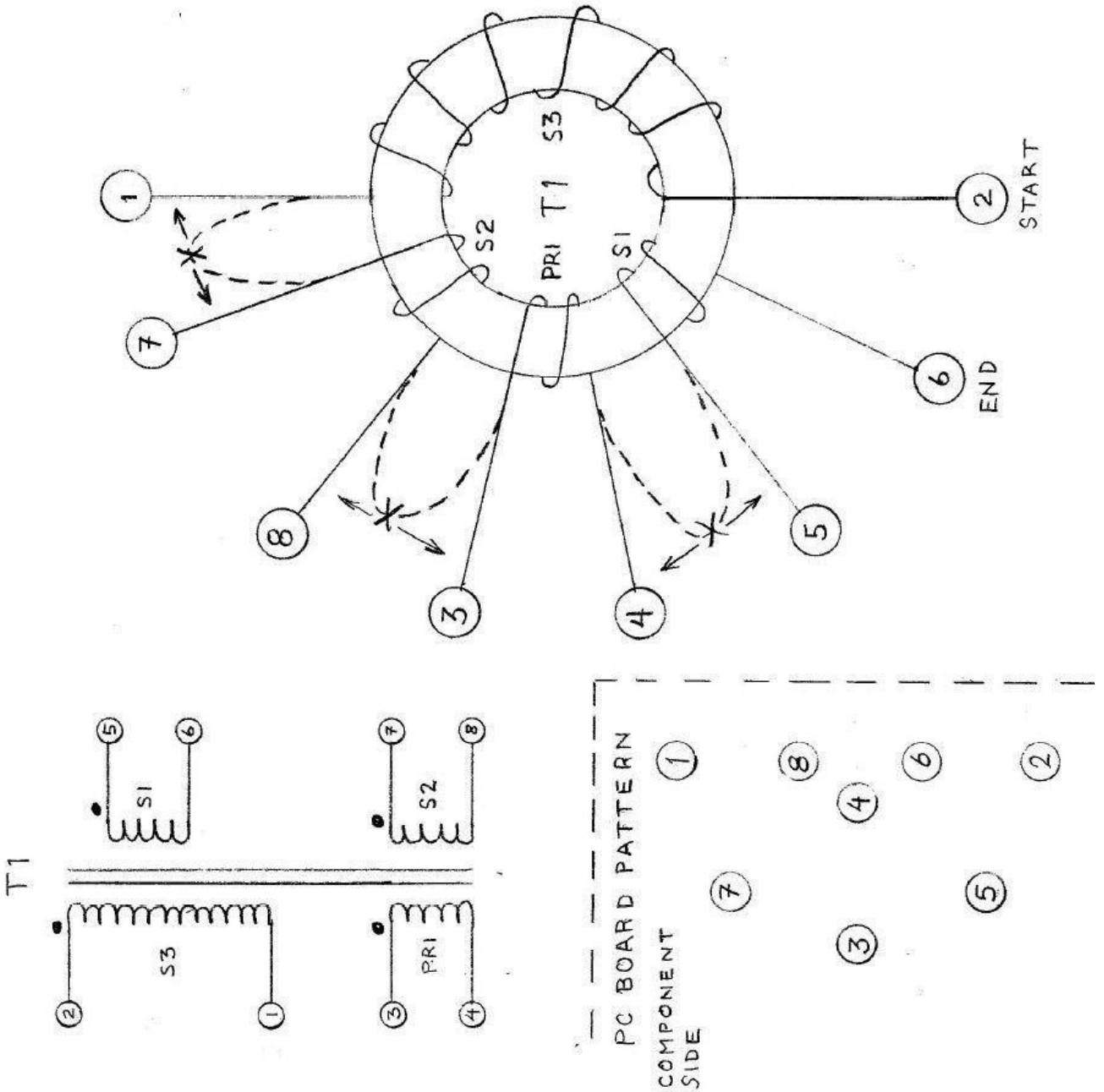

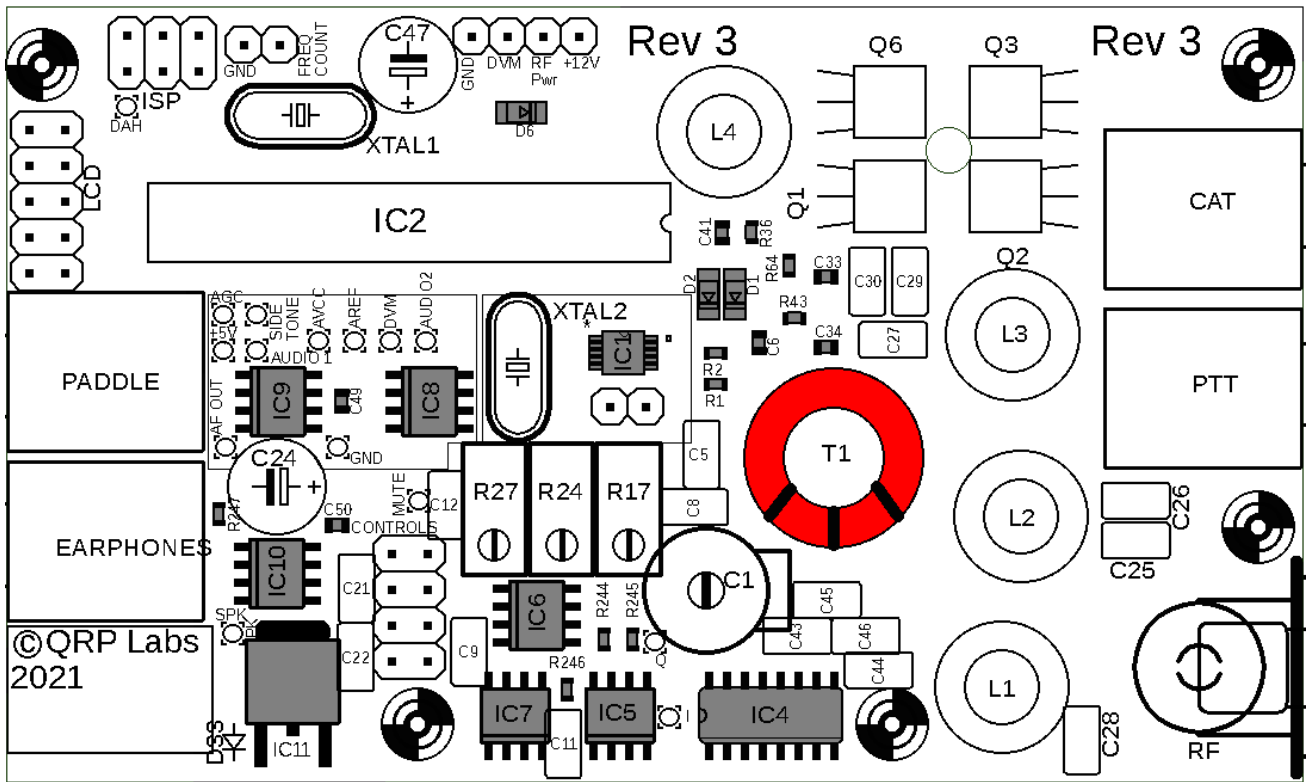

The number of turns in each winding depends on the band you are building the kit for. Refer to the following table. **For convenience, the remainder of the instructions in this section refer to the 40m version (38 + 5 + 5 + 5 turns).**

But MAKE SURE you wind the correct number of turns and toroid for your band!

Band	Toroid	Primary	Secondary	Secondary	Secondary
			1	2	3
160m	FT50-43	3	3	3	10
80m	T50-2	5	5	5	68
60m	T50-2	5	5	5	46
40m	T50-2	5	5	5	38
30m	T50-2	4	4	4	30
20m	T50-2	3	3	3	30
17m	T50-2	3	3	3	22

Note for 80m and 60m versions: the toroid ring is not large enough to neatly hold all of those turns in a single flat tidy winding. The large secondary winding WILL end up looking messy, with overlaps in some places. You should try to ensure any overlaps turns are evenly spaced throughout the winding! Do not try to wind one neat layer, then wind the remaining turns as an additional neat layer on top of that. Just go with the messy overlapping turns and don't worry about it: everything will work fine, regardless.

There is a suggested modified way of winding the turns for 60/80m versions, which may make it easier; see <http://www.qrp-labs.com/qcx/qcxmods.html#80m>

In all cases, there is one long secondary winding, and three other short identical windings. To make things easier, we will wind all windings together in one go, this will guarantee that the “sense” of each winding will be the same. At the intended breaks between the windings, we will leave large loops of wire, that we can later cut one by one to make sure the wires go in the correct holes.

There are a lot of steps listed below but in reality, it is easier DOING it than it is writing instructions how to do it. Take it patiently, step by step.

- 1) Hold the toroid between thumb and finger, and thread the first turn of the wire through from top to bottom. Leave about 3cm of wire at the free end.
- 2) Apply tension to the wire after each pass through the center hole, to try to keep the windings tight and even. The wire turns should sit neatly side-by-side on the toroid, without overlapping.
- 3) Grip the toroid between thumb and finger as you wind.

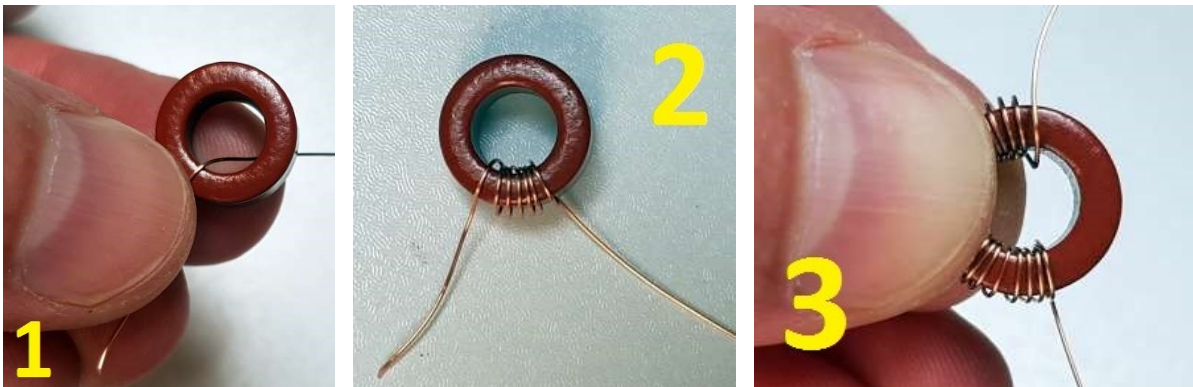

- 4) When you have completed 38 turns, pass the wire through the hole for the 39th turn but leave a large loop of wire between the 38th and 39th, without pulling it tight.
- 5) Grip the toroid and wound turns tightly between thumb and finger, and with the other hand apply some twists to the wire loop, tight next to the toroid.
- 6) The result is a wire loop after 38 turns, as shown.

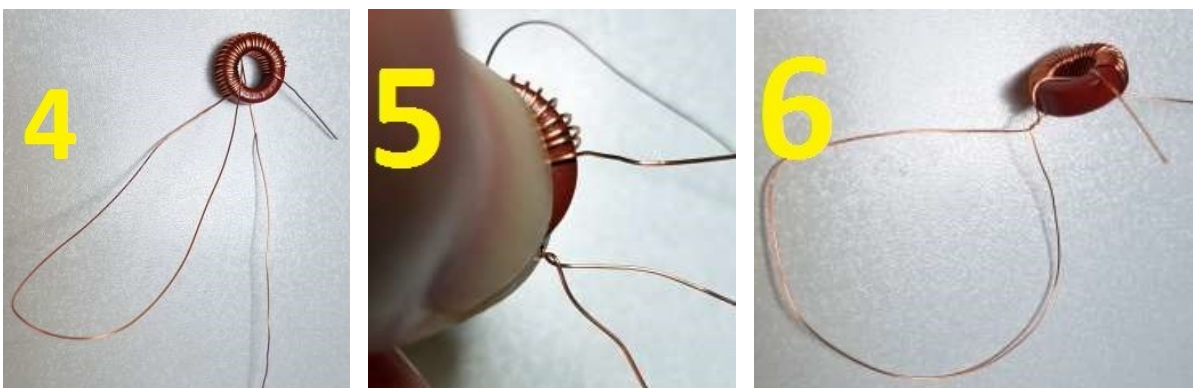

- 7) Do the same thing for two more loops, which are between the 43rd and 44th turns, and 48th and 49th turns respectively. It is easy to lose count. An easy way is after step 6, pass the wire through the hole 5 more times, and on the 5th one, make a loop. Similarly count five more and make a loop on the fifth. Then finally five more turns to complete the toroid's 53 windings. Count the windings to make sure you have 53. When you are sure everything is fine, cut the wire leaving about 3cm of wire free at the end.
- 8) Thread the original start of your winding (from step 1) into hole 2 in the diagram. Thread the final end of your winding (from step 7) into hole 6
- 9) Twist these two wires under the board to keep the toroid in place while you deal with the remaining wires.

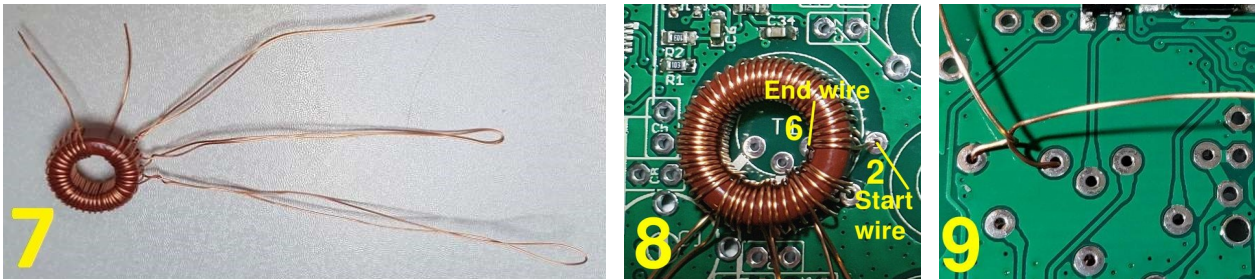

- 10) Now cut the 3rd loop (the one nearest the end of the winding work), and un-twist the twisted section you made near the toroid body.
- 11) When you cut the loop, you therefore created two wires. One of these came over the top of the toroid, and you can easily verify that this is the one which has five turns through the toroid then passes through hole 6. So, insert this wire into hole 5. Once again to be clear: you should now have a winding of five turns (which is labeled "secondary 1", above), with one end inserted into hole 6 and one end inserted into hole 5. The other wire came from UNDER the toroid. You must push this wire towards the toroid and pull it out through the center hole of the toroid. Now thread it through hole 4. Under the board, twist the two new ends of wire together to keep them in place.

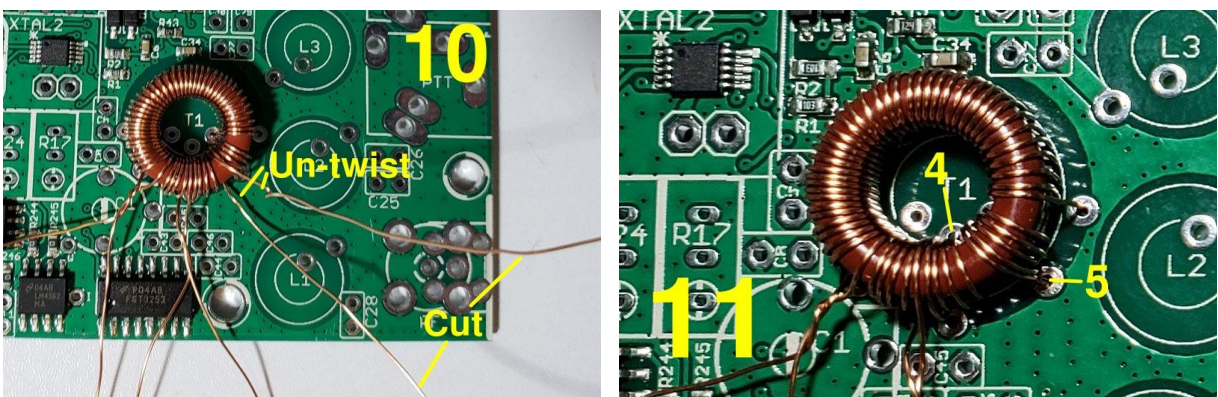

12) Next cut the 2nd loop, and un-twist the twisted section near the toroid body.

13) Similar to step 11; the wire which came over the toroid body has five turns then goes into hole 4, which you did in step 11. Insert this wire-end into hole 3.

The other wire end that came from under the toroid body should be gently pushed toward the toroid, and pulled up through the center hole of the toroid. Insert that wire end into hole 8. So now you have the “primary” winding consisting of five turns, between holes 3 and 4.

Twist the two new wires under the board again, to keep everything in place.

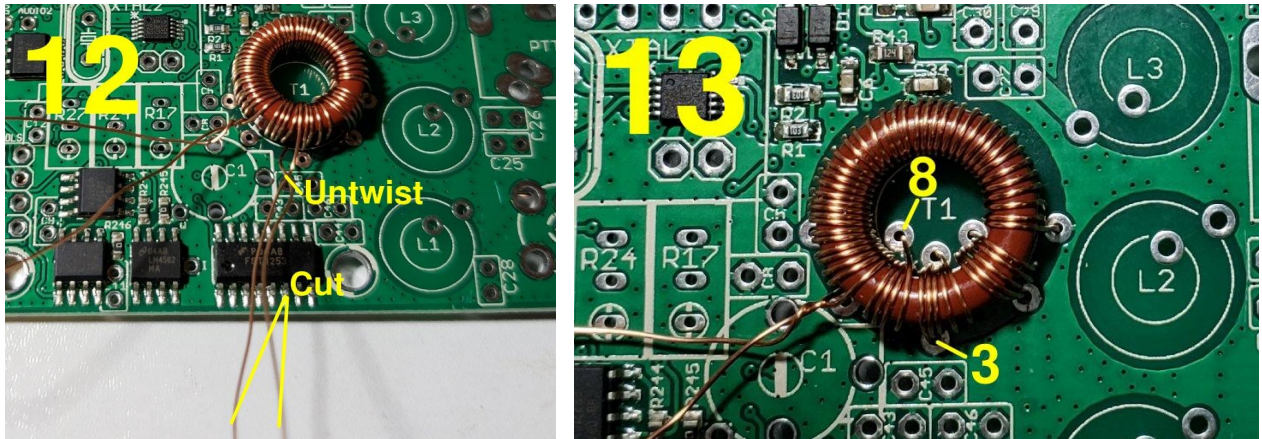

14) Finally, cut and un-twist the loop which you created first, which was between the 38th and 39th turns of the toroid winding. Push the wire which came over the toroid body, into hole 7. Now you have five turns of wire, which make up “secondary 2”, between holes 7 and 8.

15) The last wire came from under the toroid body when you cut the loop; this wire is the other end of the 38 turns “secondary 3” winding, so insert it into hole 1. It is already near to hole 1 and you don’t need to push it under the toroid body as you did in previous steps.

Take a moment now to review the situation. You should be able to identify the four windings of T1, and squeeze them together neatly as in the photo, to verify that each end of the 5-turn windings goes into the correct holes.

16) Under the PCB, you should have three pairs of twisted wires, and one pair (that you installed last), un-twisted.

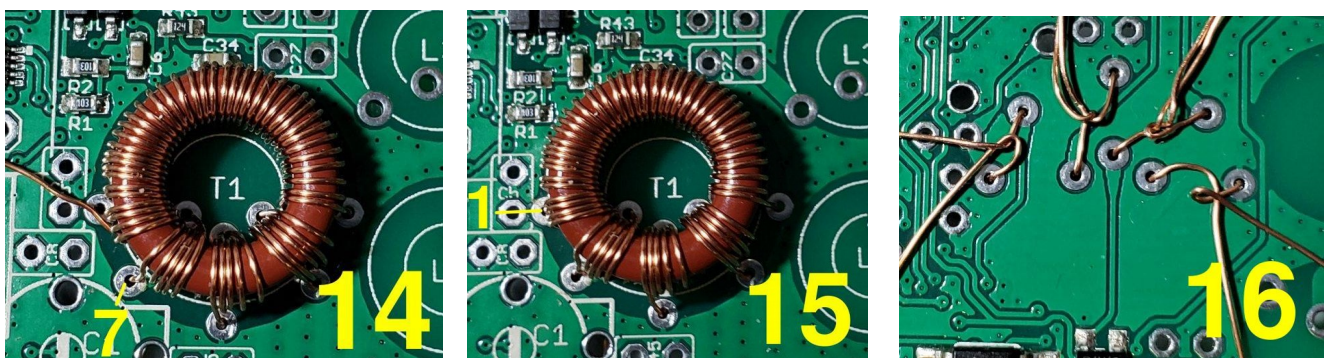

17) Now you can solder the eight connections under the PCB. I recommend doing one pair of wires at a time; this way, the other wires will hold the toroid in place and stop it falling out. Start with the two un-twisted wires. Pull each wire tight, bend it over at about 45-degrees, and cut it 1-2mm away from the PCB surface. Having bent the wire prevents it from falling out. Now solder the wire. Remember to hold the soldering iron to the joint for 10 seconds or so, to allow the enamel insulation to burn off.

Repeat for all the other wires, one pair at a time, until all eight are soldered. If you have a DVM, check for DC continuity (zero ohms resistance) across each winding. If you do not get the expected continuity, then it means either

a) you have not managed to scrape or burn away the enamel insulation properly so there is no electrical connection AND/OR

b) you put the wires into incorrect holes AND/OR

c) your expectation is wrong because you have not identified which pad on the PCB is labeled 1-8 in the diagram.

18) The final picture shows the toroid installation completed.

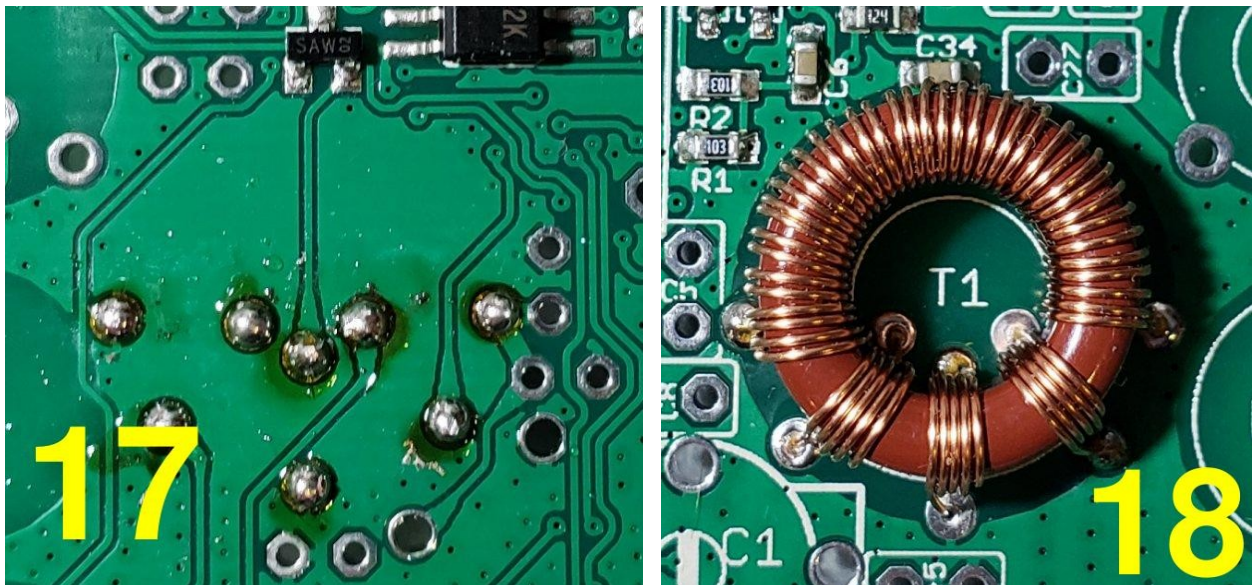

3.3 Install IC2 socket

PUSH IT UP TOWARDS THE TOP OF THE BOARD, TO MAKE MORE SPACE FOR THE TCXO PCB

Install the 28-pin IC socket for IC2. Take care to match the dimple on the socket, with the dimple on the PCB silkscreen. It is critical to insert the microcontroller with the correct orientation. Lining up the dimple on the PCB silkscreen, socket and actual IC is the best way to avoid confusion and potential error.

There is some leeway in where exactly the socket is placed, because the pins are smaller than the diameter of the PCB holes. Try to position the socket as far towards the top edge of the PCB as possible (oriented as the diagram). This is necessary, to create sufficient space for the Paddle and Earphones connectors; and also to create enough space for the TCXO daughterboard PCB and the uSDX daughterboard PCBs if fitted.

I recommend soldering one pin at each diagonal, for example pins 1 and 15. You can then check that the IC socket is seated firmly on the PCB, and correct any issues easily. Once all the pins are soldered it will be difficult, if not impossible, to change anything. When you are happy with the position of the socket, proceed with soldering the other 26 pins.

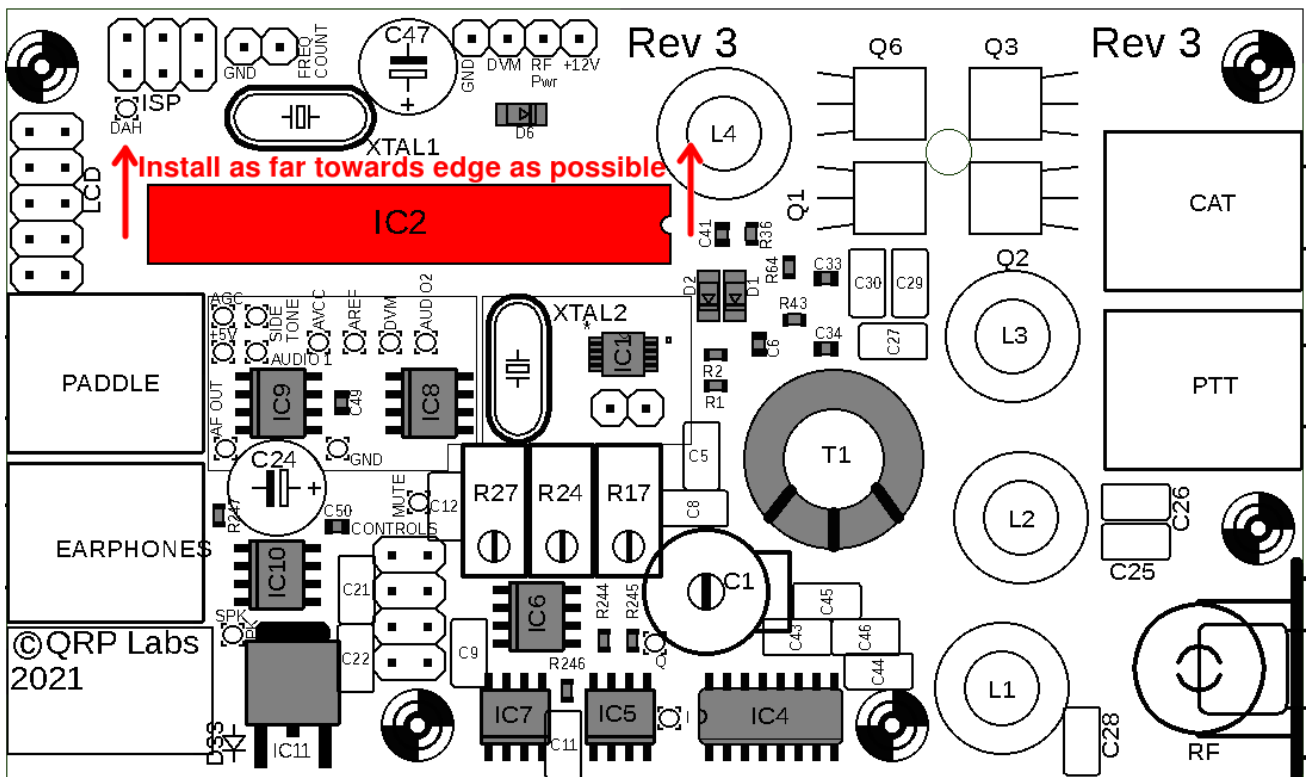

3.4 Install 100nF (0.1uF, “104”) capacitors

There are two 100nF (0.1uF) capacitors, these have the code “104” written on them. Be sure to identify the correct capacitors, using a magnifying glass or jeweler's loupe. These capacitors are C12 and C29. Place each in the correct position on the board, and slightly bend the legs outwards at about 30-degree angle so that they stay in place. Then solder the wires, and trim the excess wire length with wire cutters.

It does not matter which way round the capacitors are installed. However, it is very good practice to install them all with the capacitor label facing in the same direction. For example, ensure all the “104” labels face to the front, or to the right (depending which way the capacitor is orientated on the PCB). This makes it much easier to inspect the PCB assembly later.

An exception to this “rule” is where a component label cannot be read, if it is facing the common direction; an example in this kit is C12 (in this section), which should be installed with its label facing away from R27 so that it can be easily checked later.

Take particular care soldering wires which connect to the ground plane. Despite the “thermals” (a ground pad is connected to the ground plane by four thin traces, not a continuous ground plane, to make soldering easier), the heat dissipation is still more, and it can be harder to make a good joint.

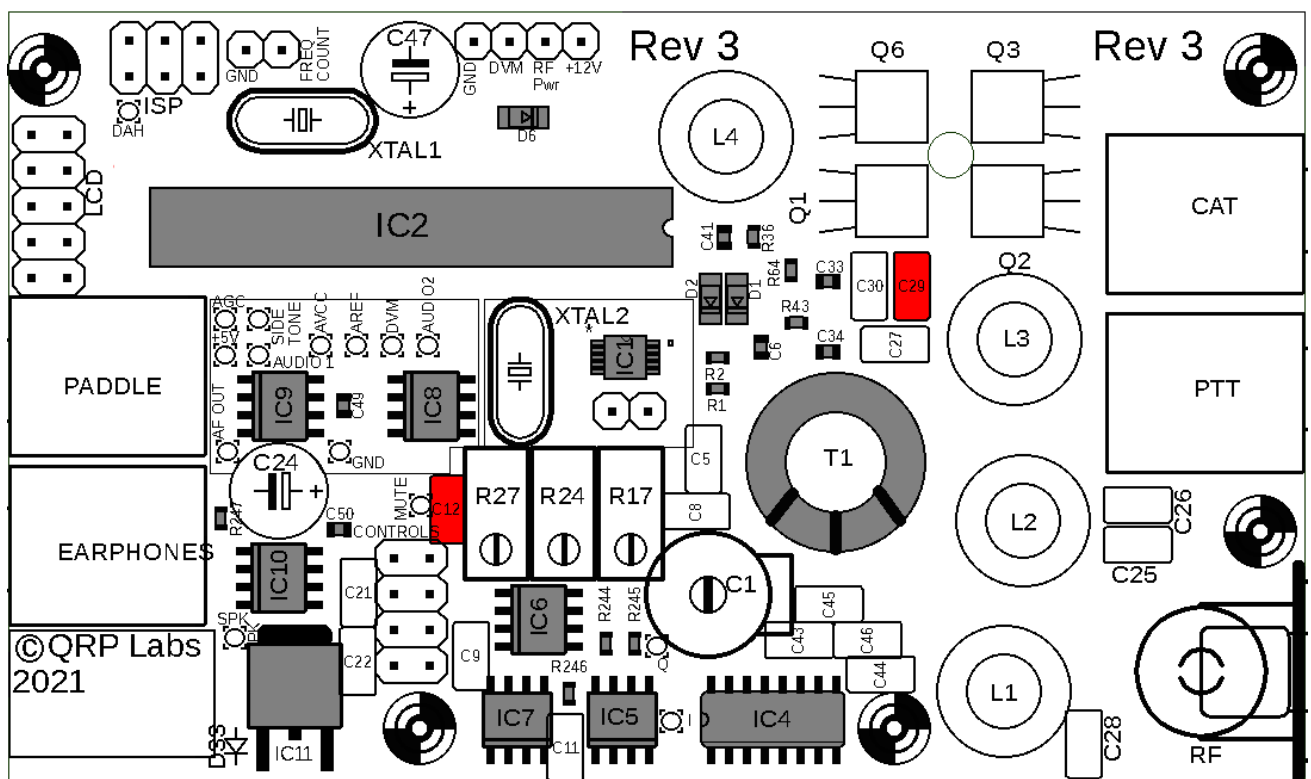

3.5 Install all 470nF, “474” capacitors

The five 470nF capacitors are labeled “474”, and are capacitors C11, C43, C44, C45 and C46.

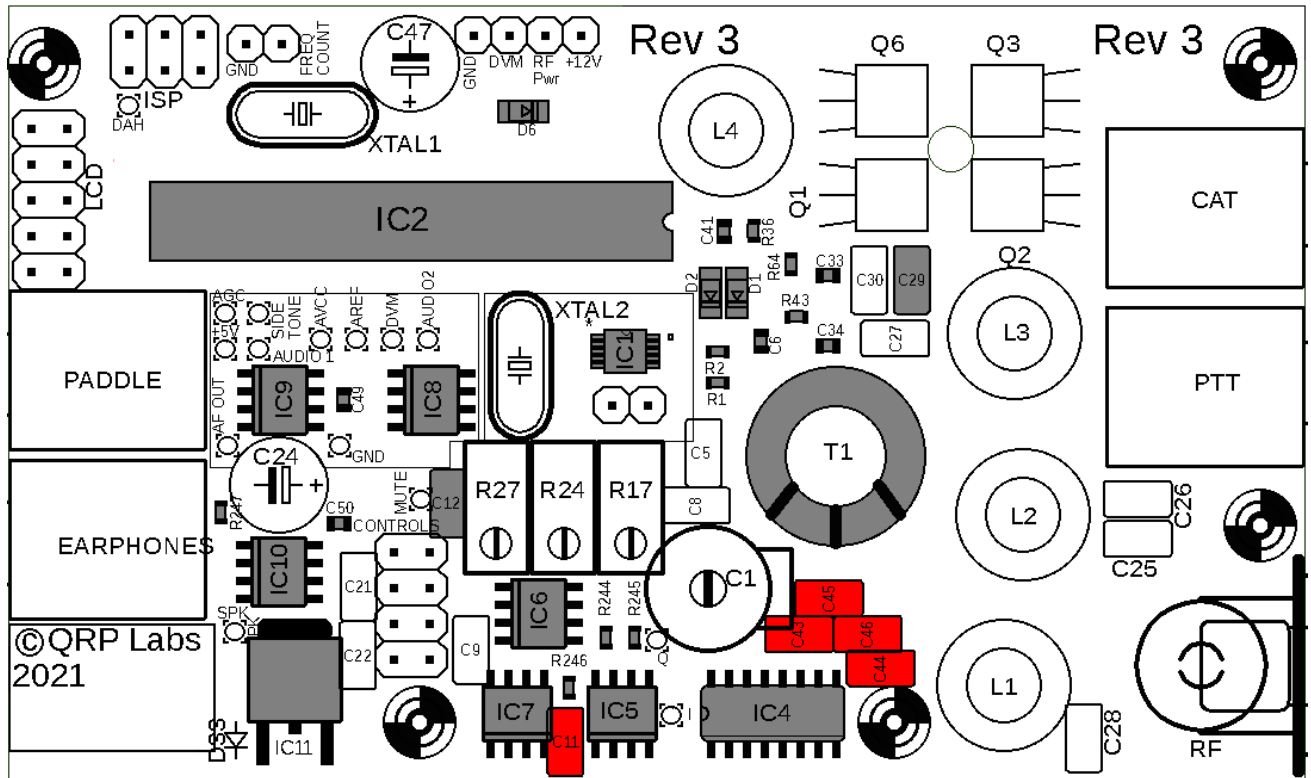

3.6 Install 47nF, “473” capacitor

The 47nF (0.047uF) capacitor is labeled “473” and is capacitor C9.

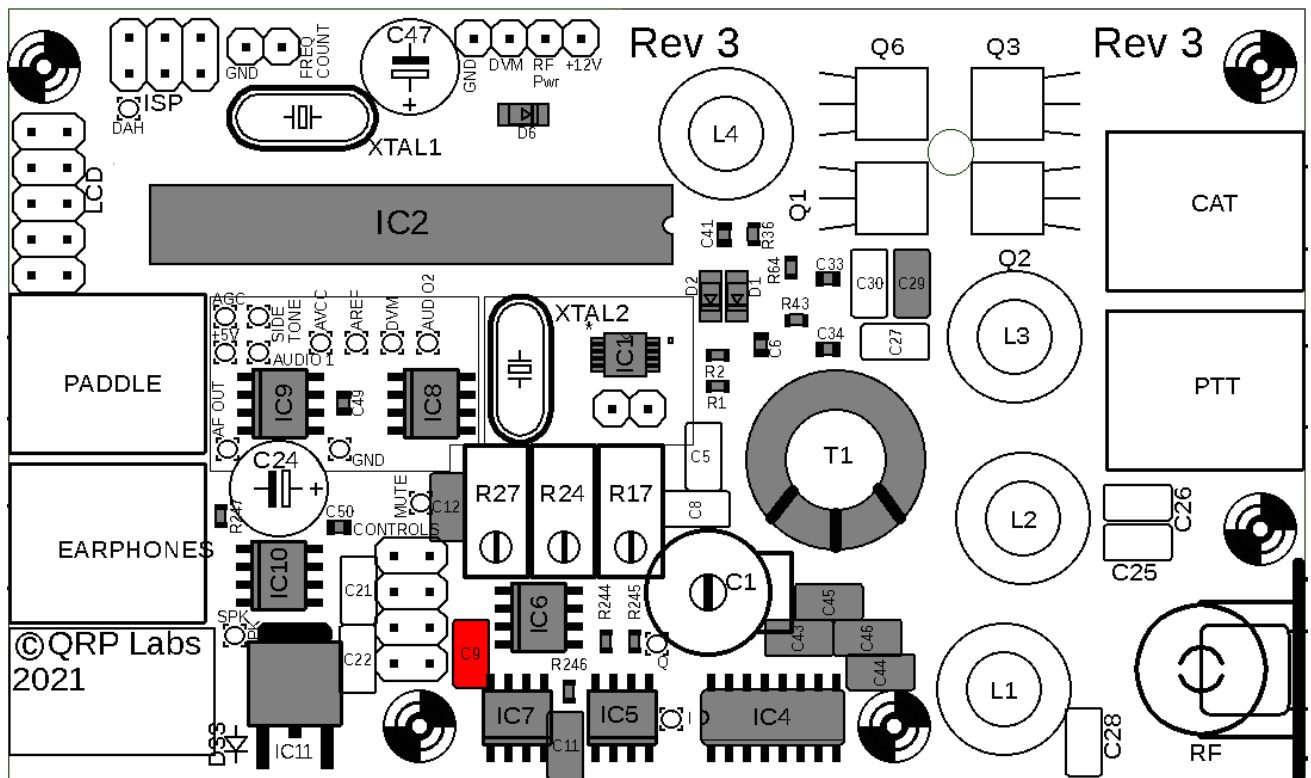

3.7 Install capacitors C25 and C26 from Low Pass Filter kit

The value of these capacitors depends on your chosen band. The capacitors are located inside the separate Low Pass Filter bag in your main kit bag. Refer to the following table to find the correct capacitor value for your band:

Band	Value	Label
160m	2200pF	"222"
80m	1200pF	"122"
60m	1200pF	"122"
40m	680pF	"681"
30m	560pF	"561"
20m	390pF	"391"
17m	270pF	"271"

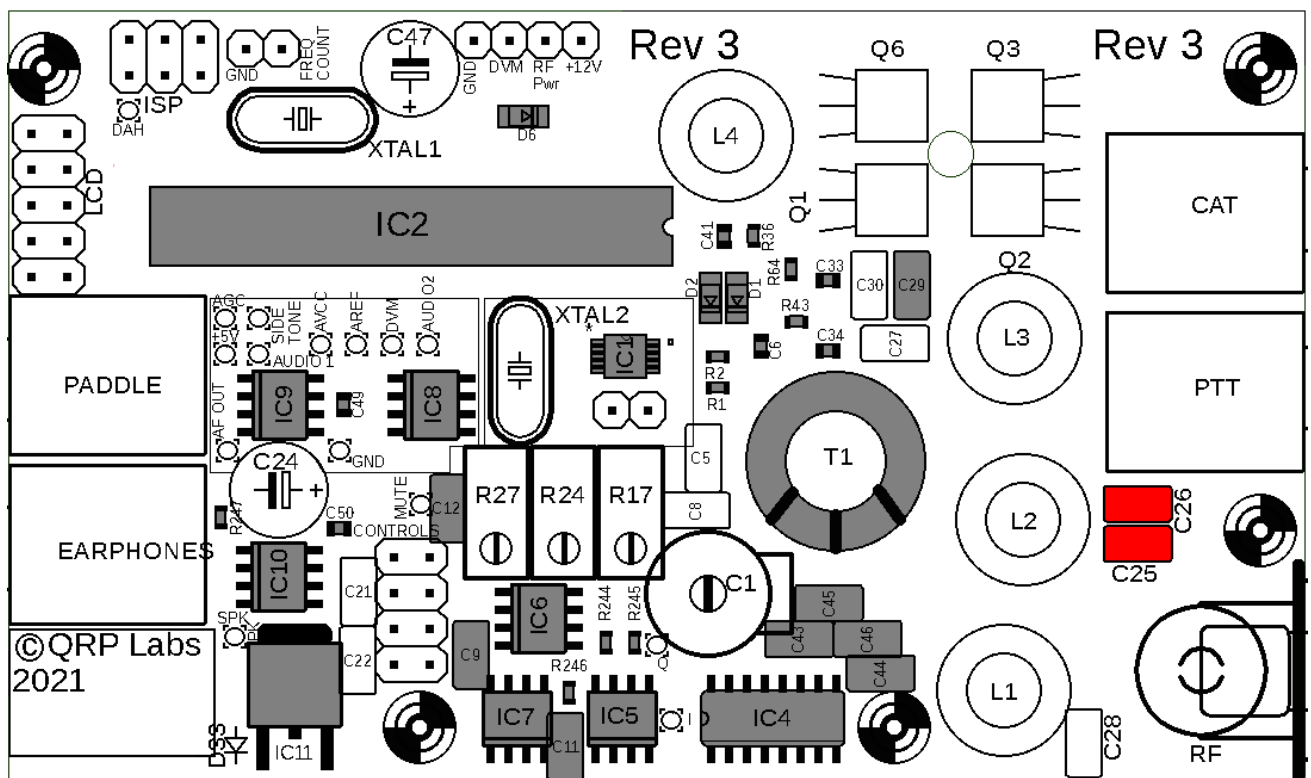

3.8 Install capacitors C27 and C28 from Low Pass Filter kit

The value of these capacitors depends on your chosen band. The capacitors are located inside the separate Low Pass Filter bag in your main kit bag. Refer to the following table to find the correct capacitor value for your band:

Band	Value	Label
160m	820pF	"821"
80m	470pF	"471"
60m	680pF	"681"
40m	270pF	"271"
30m	270pF	"271"
20m	180pF	"181"
17m	100pF	"101"

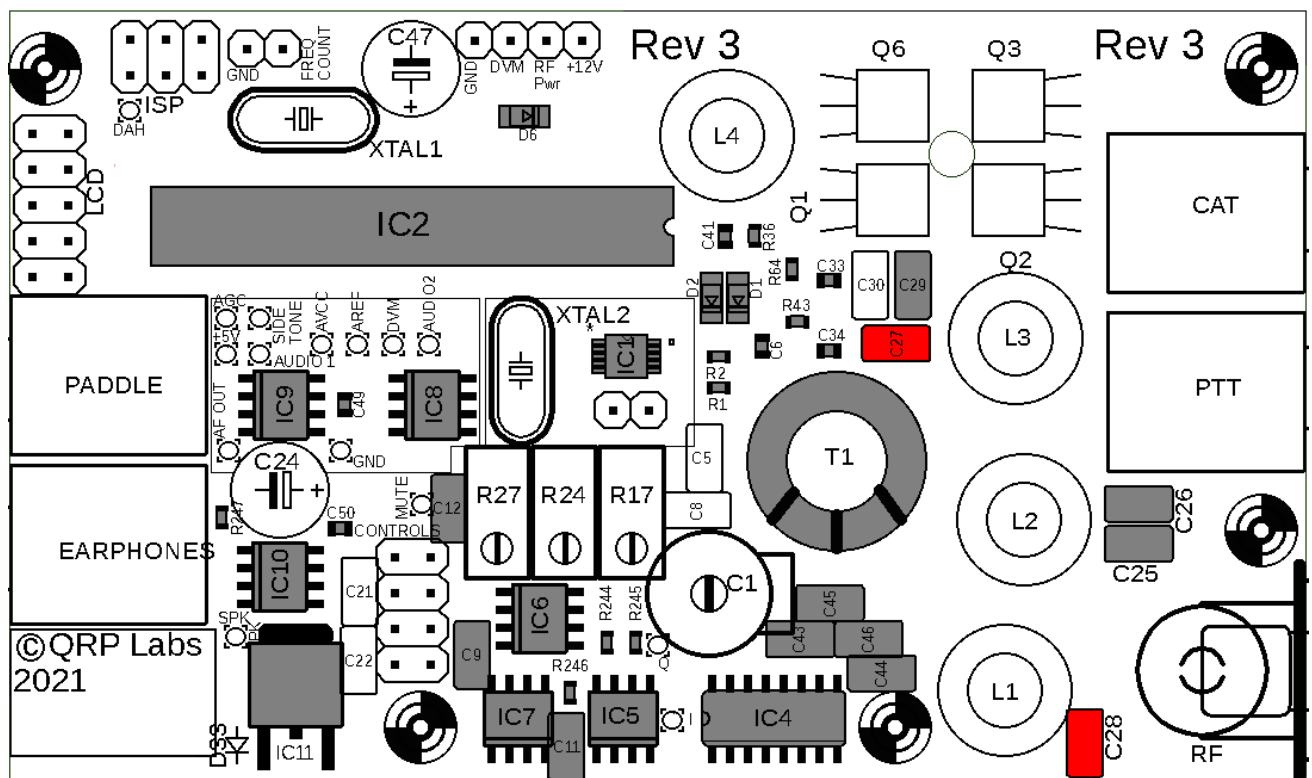

3.9 Install capacitor C30

This capacitor is band dependent. The kit contains all required capacitor values for all bands. Install the one appropriate to your band. Refer to the following table to find the correct capacitor value for your band

Band	Value	Label
160m	820pF	"821"
80m	180pF	"181"
60m	30pF or 33pF 56pF	"300" or "330" "560"
40m	56pF	"560"
30m	30pF or 33pF	"300" or "330"
20m	30pF or 33pF	"300" or "330"
17m	30pF or 33pF	"300" or "330"

Note that for 40m and 80m versions, the 56pF and 180pF capacitors respectively, may be packed in a separate small bag with the T37-2 and T50-2 toroids.

Note that your kit might contain a 30pF or 33pF capacitor, as shown in the table. It is not critical which one you have, either is OK.

60m important note: for the 60m band, the capacitor requires both the 30pF and 56pF capacitors to be soldered in parallel, but there is only one component position on the PCB. For 60m, you will need to install one of the capacitors (e.g. 56pF) in the component holes provided, and solder the other one (e.g. 30pF) to the same pads under the PCB. Take care to keep the component wires short and not accidentally touching any other nearby components or soldered pads.

80m important note: the 180pF capacitor supplied has a 0.2-inch (5.08mm) pin spacing. But the holes on the PCB are spaced 0.1-inch (2.5mm). It is necessary to squeeze the capacitors wires carefully closer together to fit the PCB holes.

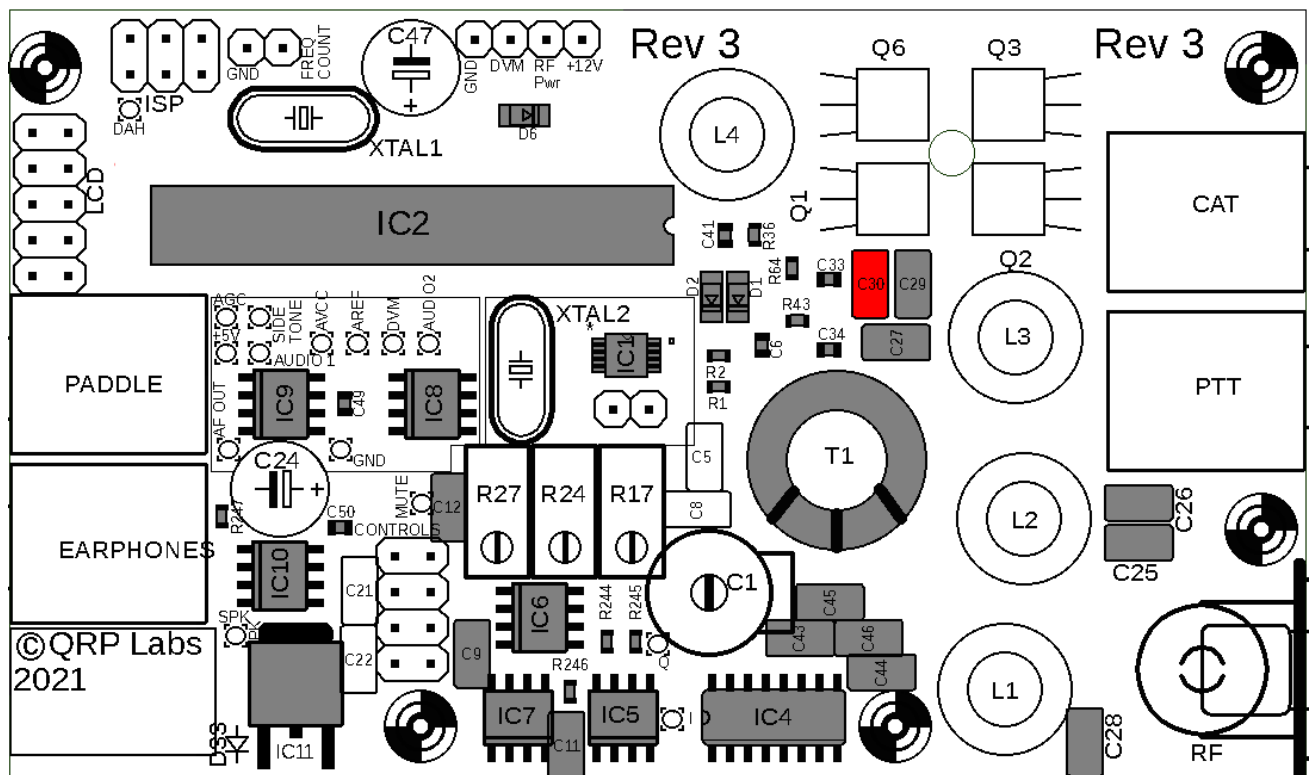

3.10 Install capacitors C5 and C8

These capacitors are band dependent. They add parallel capacitance to trimmer capacitor C1 to bring it to the required value. The kit contains all required capacitor values. Install the capacitor(s) appropriate to your band. Refer to the following table to find the correct capacitor value(s) for your band. Where “none” is indicated in the table, do not install the corresponding capacitor.

Band	C5 Value	C5 Label	C8 value	C8 Label
160m	100pF	“101”	22pF	“220”
80m	39pF	“390”	22pF	“220”
60m	39pF	“390”	22pF	“220”
40m	39pF	“390”	none	
30m	22pF	“220”	none	
20m	none		none	
17m	none		none	

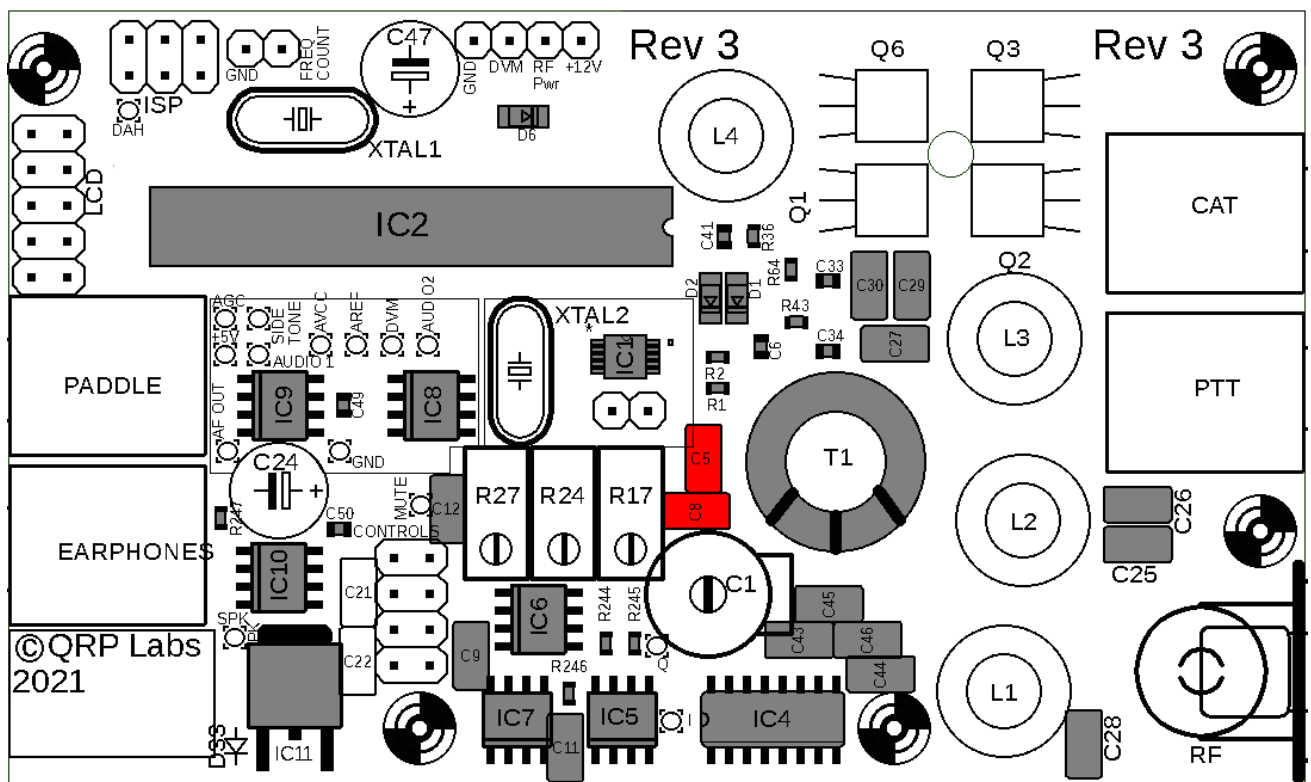

3.11 Install 1uF, “105” capacitors C21, and C22

There are two 1uF capacitors labeled “105”, which are C21 and C22.

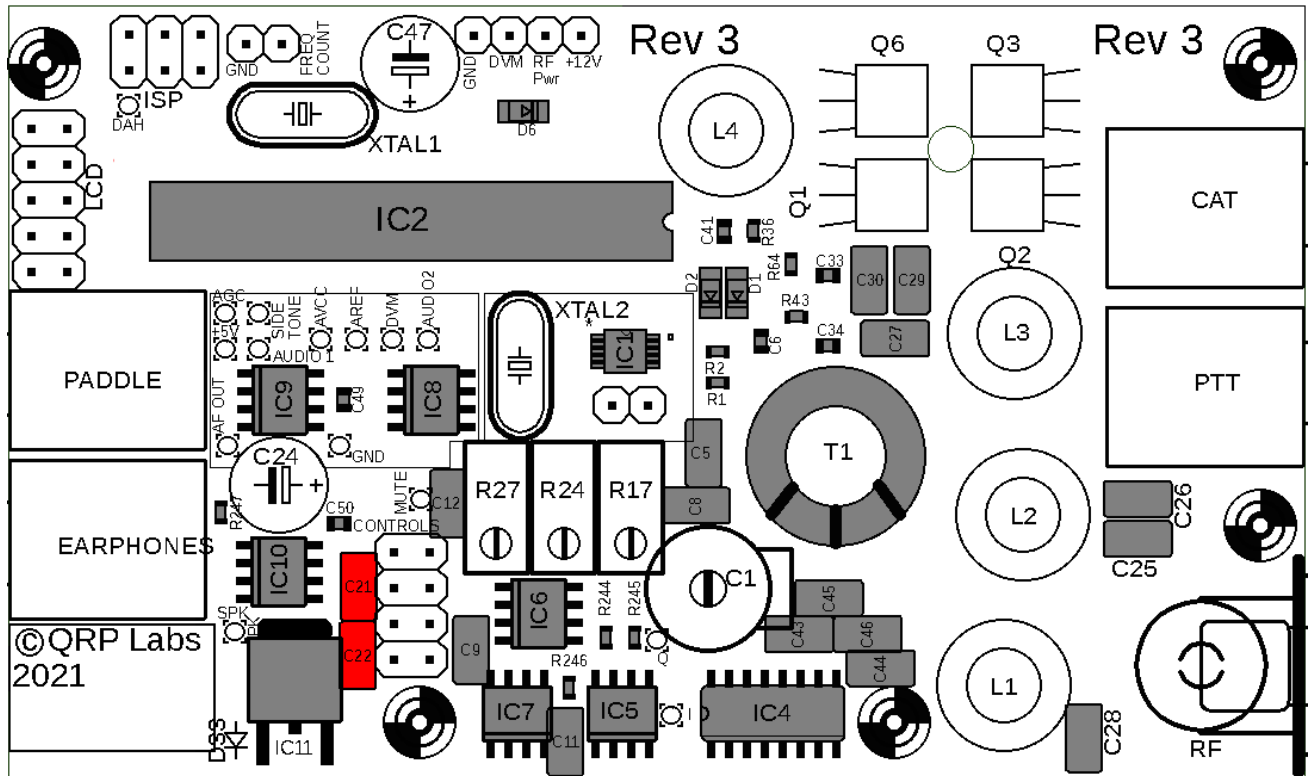

3.12 Install 1N5819 diode

This diode D33 is the diode with a black body, and a white stripe. It is installed vertically. It must be orientated correctly, with the white stripe on the diode matching the white stripe on the PCB.

This diode protects the radio against reverse polarity. So that if you connect the power to the board the wrong way around, you do not destroy it. A Schottky diode is used because the forward conducting voltage drop is less than an ordinary diode. However, on transmit, the voltage drop across this diode can still be up to 400mV. This reduction in voltage does slightly decrease the output power.

IF you want to squeeze every last milliwatt of output power out of the radio, and IF you trust yourself NEVER to connect the power supply in reverse by mistake, then if you just install a jumper wire instead of D33, it would give you a little higher RF power output. **It is very strongly recommended to install D33.**

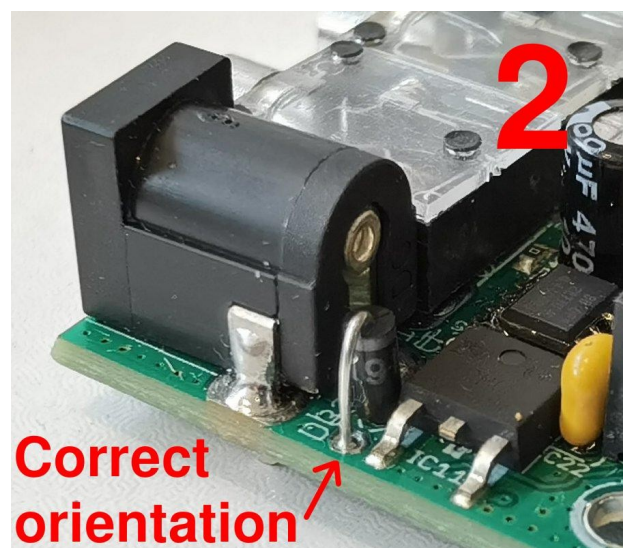
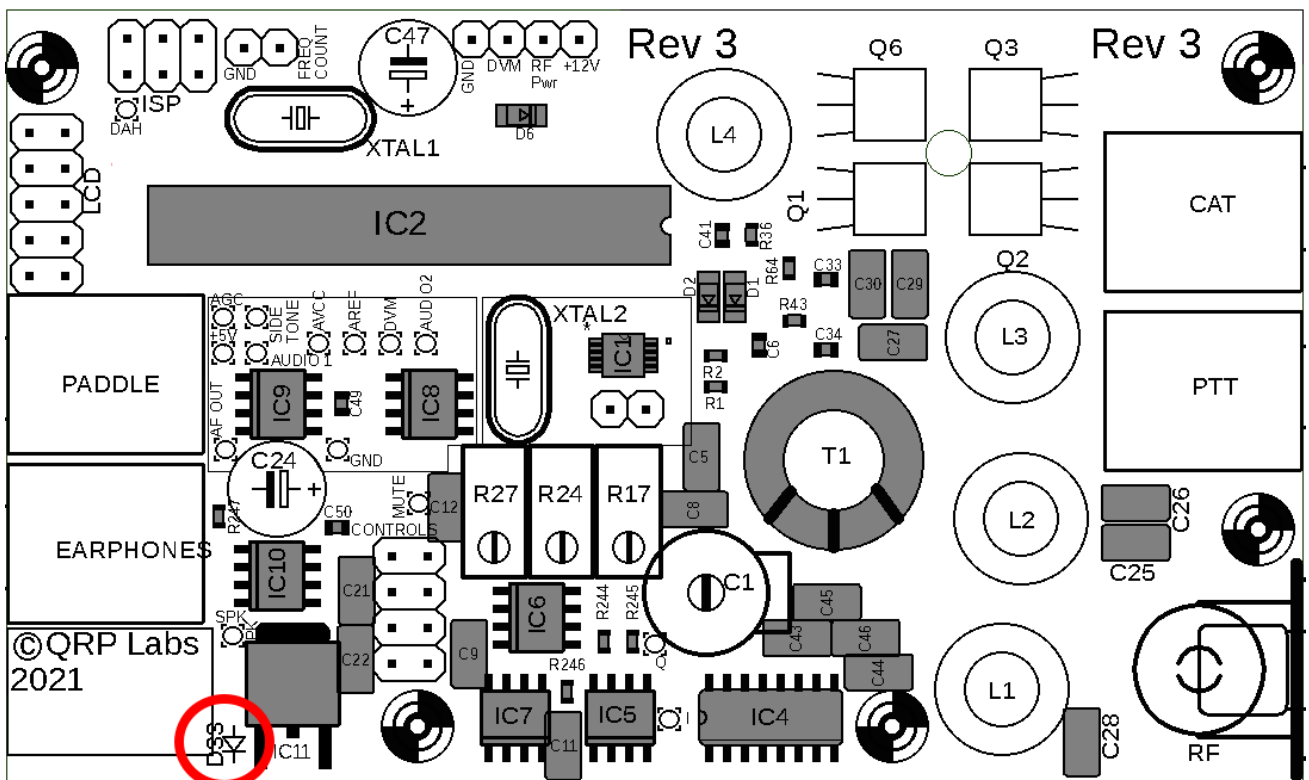

3.13 Install 20MHz crystal XTAL1

The engraving on this crystal is "20.000" or "CE20.000".

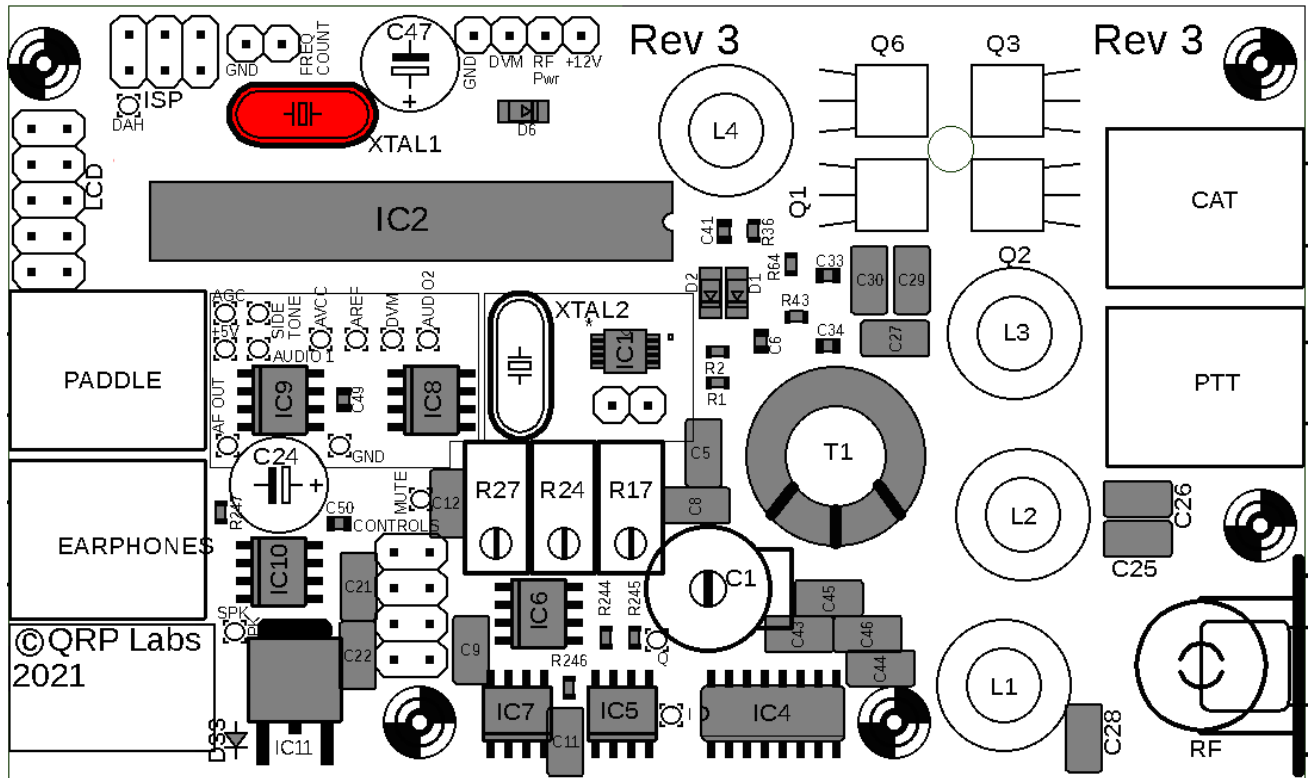

3.14 Install 27MHz crystal XTAL2 or TCXO option

Install the 27MHz crystal or 25MHz TCXO. The engraving on the crystal is "27.000". If you are going to install the 25MHz TCXO, skip this diagram and refer to the following instructions.

Menu entry 8.5 must be changed to 25,000,000 if using the TCXO

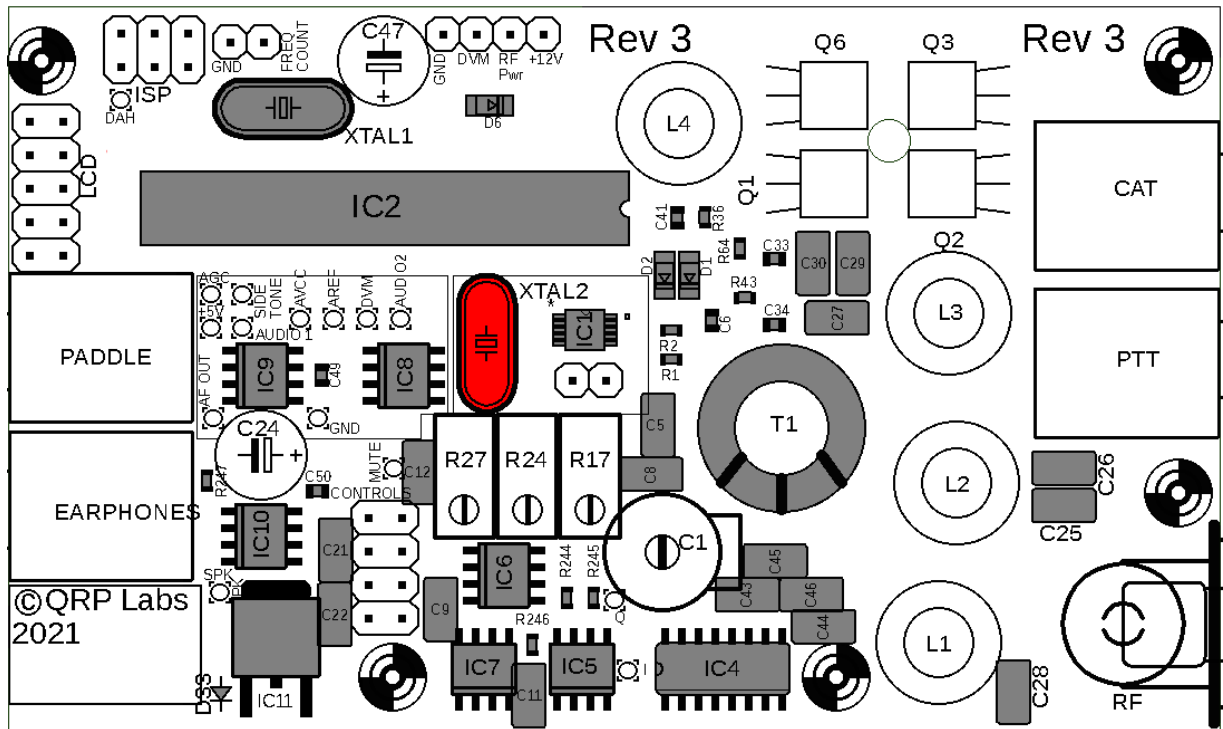

If installing the TCXO module: this is installed in the same position as the 27MHz crystal would have been. There is a rectangle on the PCB indicating the position of the TCXO:

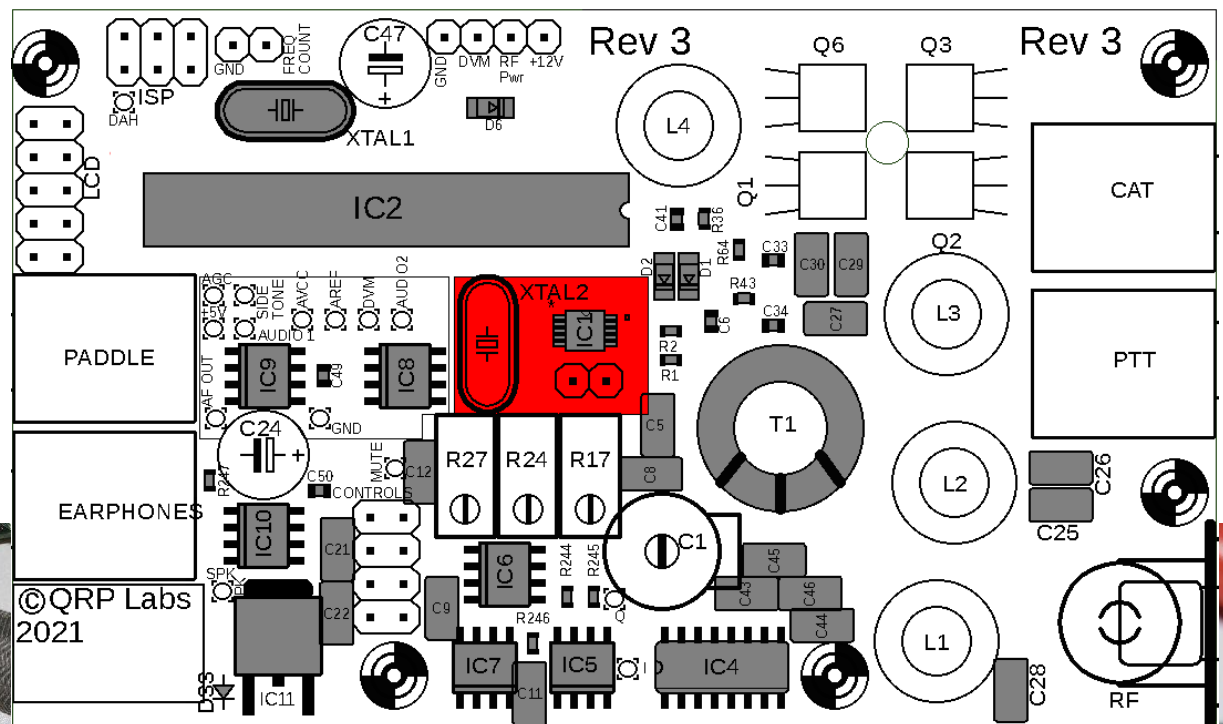

1

2

Find a suitable file.

File the rough edges of the TCXO module flat

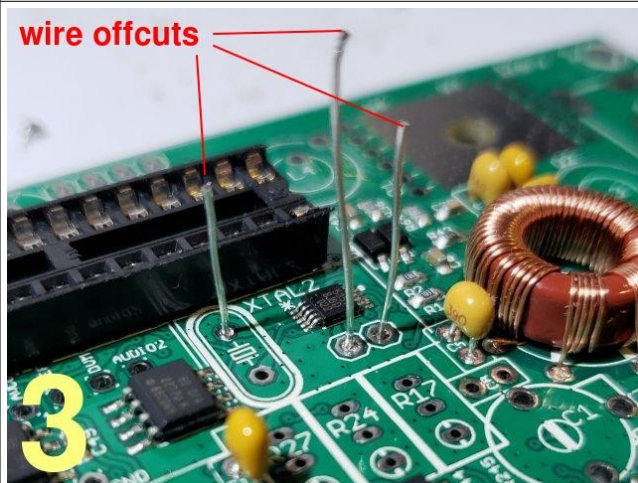

Solder wire off-cuts into the holes shown, and cut any excess wire on the underside of the board.

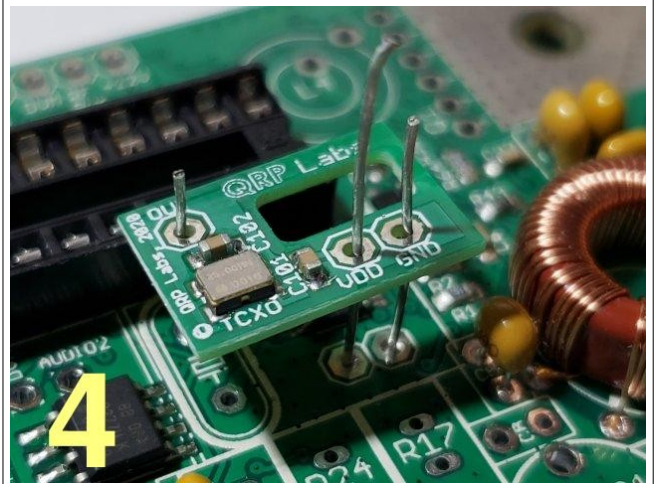

Thread the TCXO module carefully onto the wires. Make sure module is pushed as far towards the 28-pin IC socket as possible.

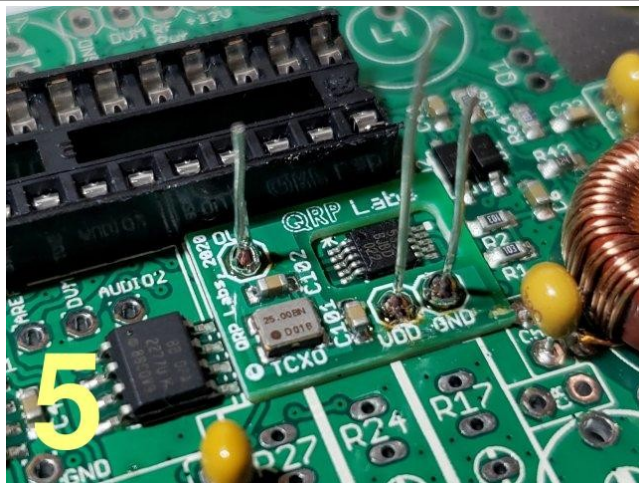

Solder the wires to the pads, holding the TCXO module firmly tight against the 28-pin IC socket.

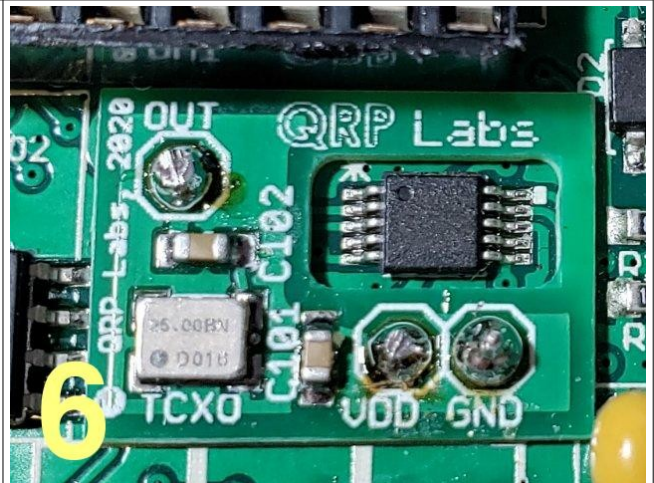

Cut off excess wire; be careful because the TCXO board is single sided without through-hole plating, so the pads are a bit delicate.

Note that when using the TCXO module, the reference frequency setting must be 25,000,000 MHz, not the default which is 27,004,000 MHz. This is further described in the initial set-up instructions, below. This is because the QCX-mini can operate either with 25MHz reference (the TCXO module) or with 27MHz (the supplied crystal), BUT, you have to tell it which one you have installed!

3.15 Install 500-ohm multi-turn trimmer potentiometer

This 24-turn trimmer resistor is the small blue box component with label "501". It is R27.

The trimmer resistor has to be prepared carefully before installation. The resistor has little ledges on either side which make it slightly too high to fit in the QCX-mini PCB assembly. Therefore simply cut off these protrusions with a wire-cutter.

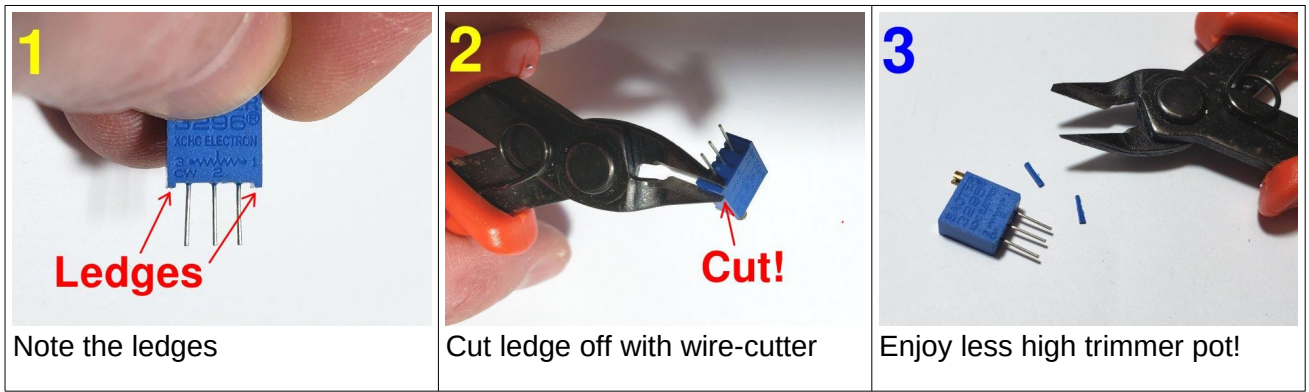

The screw on the resistor must match the screw on the PCB silkscreen and layout diagram, facing towards the lower edge of the board as drawn. Ensure it is firmly seated.

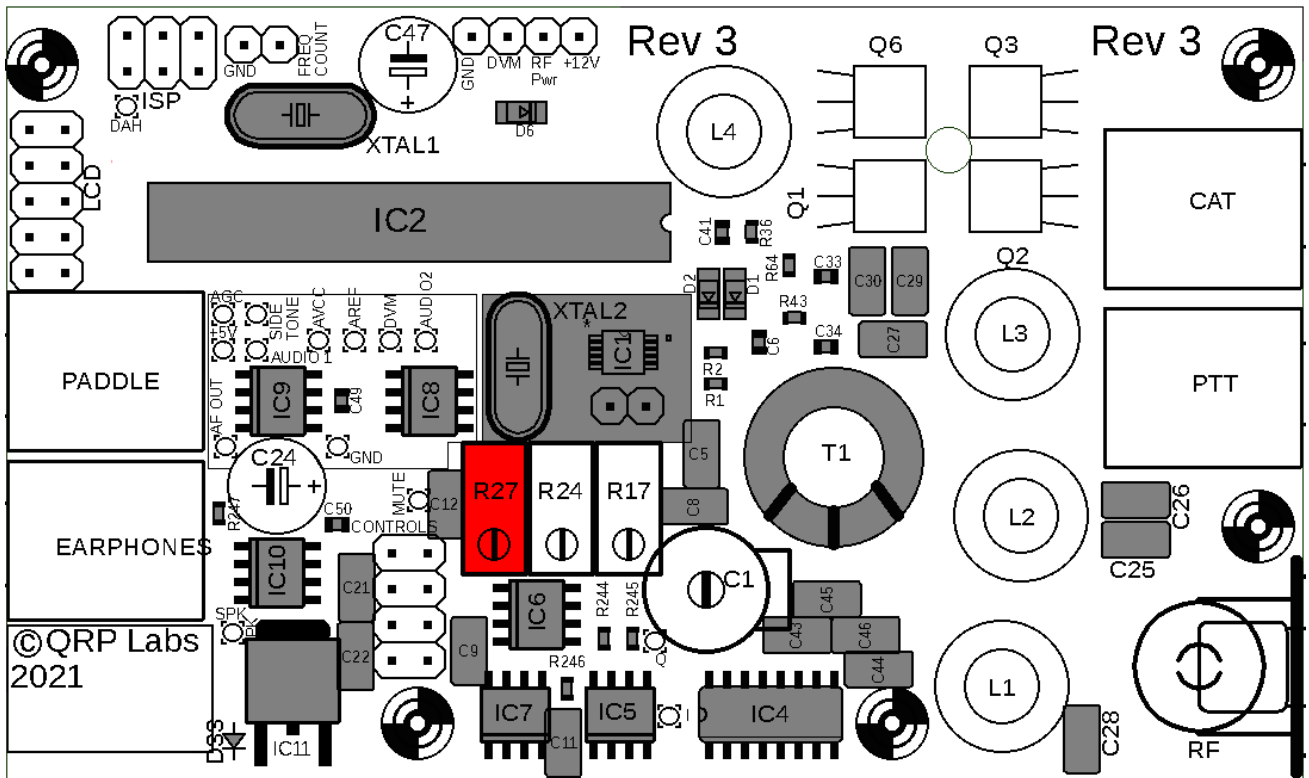

3.16 Install 50K multi-turn trimmer potentiometers

There are two 50K multi-turn trimmer potentiometers, R17 and R24. They are the small blue box components with label "503".

The trimmer potentiometers must be prepared before



installation by cutting off the small plastic ledges with a wire-cutter, as described in the preceding section.

The screws on the resistors must match the screws on the PCB silkscreen and layout diagram.

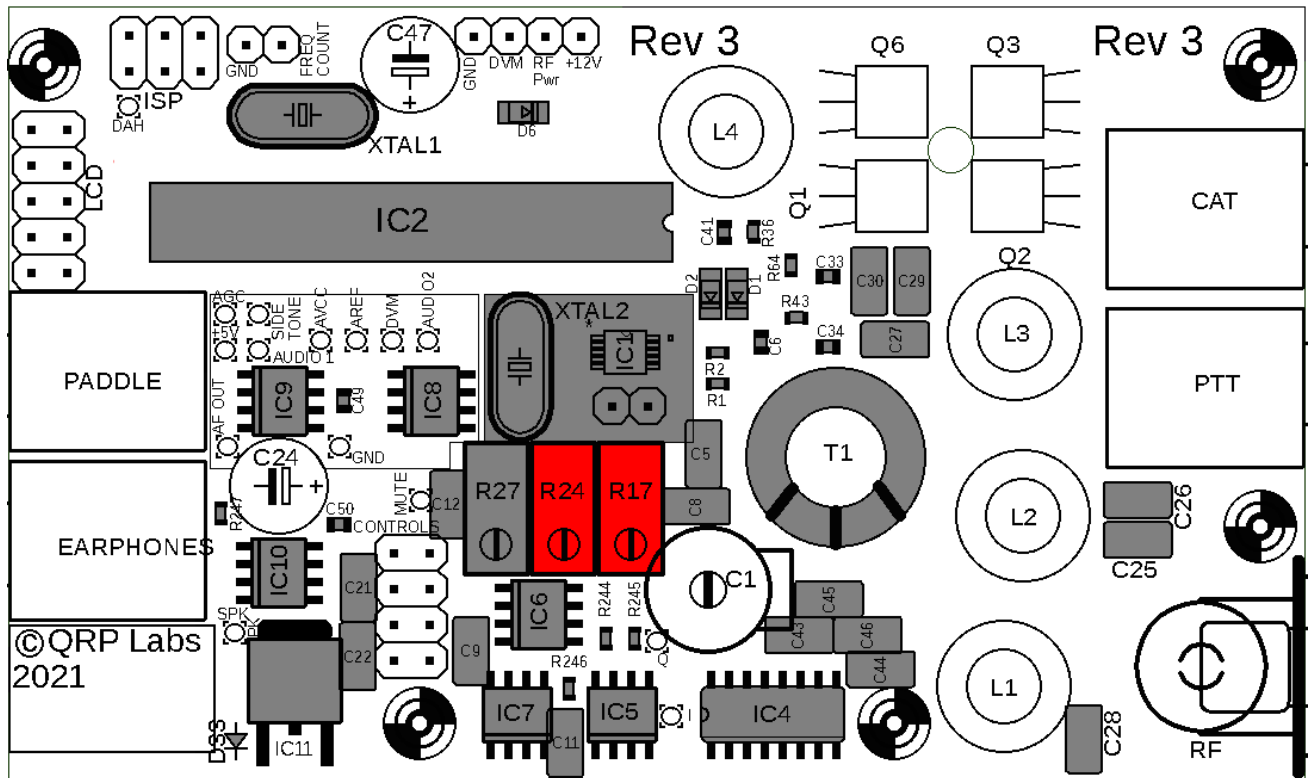

3.17 Install 470uF capacitors

There are two 470uF capacitors in the kit: C24, C47. These are polarized electrolytic capacitors and MUST be installed with the correct orientation! The capacitor NEGATIVE wire must be installed in the hole indicated on the PCB silkscreen and the layout diagram by the solid black bar; the POSITIVE wire must be installed in the hole indicated on the PCB silkscreen and the layout diagram by the hollow bar and the + symbol.

Electrolytic capacitors are also supplied with one wire longer than the other. The + wire is the longer wire, the - wire is the shorter one (see photo, right).



These capacitors must be installed on the PCB so that they are sitting flush with the PCB, with no gap between the PCB and the bottom of the capacitor.

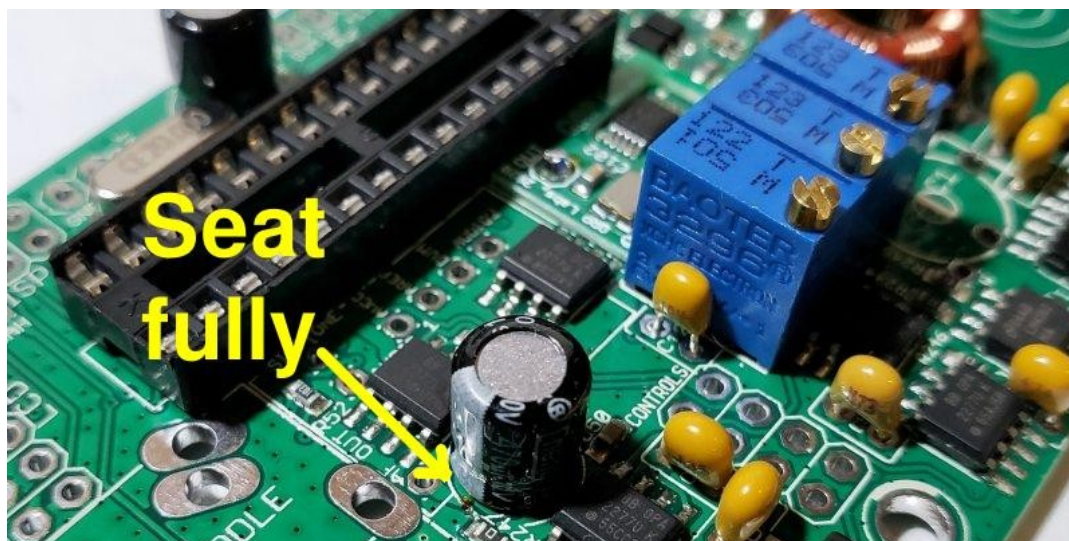
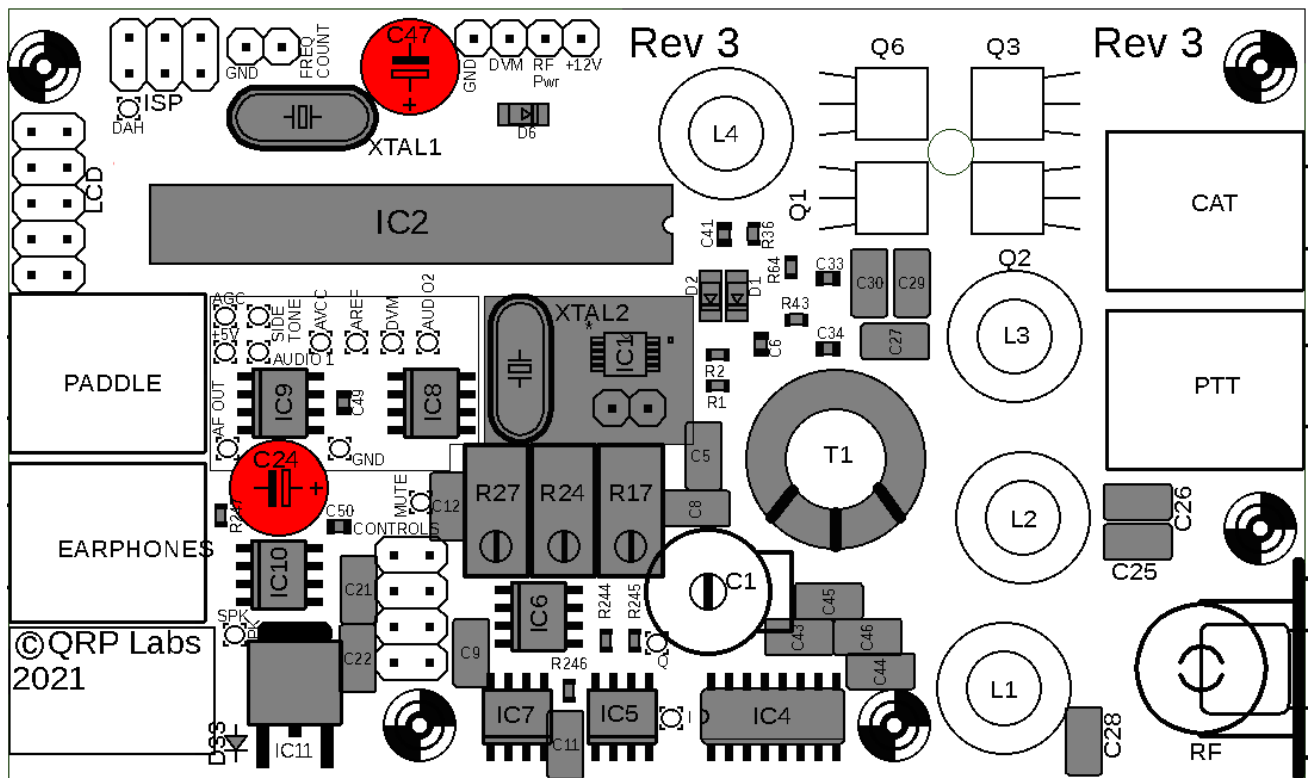

3.18 Install 30pF trimmer capacitor C1

Insert the component pins carefully and with the correct orientation which matches the PCB.

Cut the small pin stubs on the underside (solder side) of the PCB, they only protrude a few mm but when installed in the enclosure could be rather close to the aluminium floor.

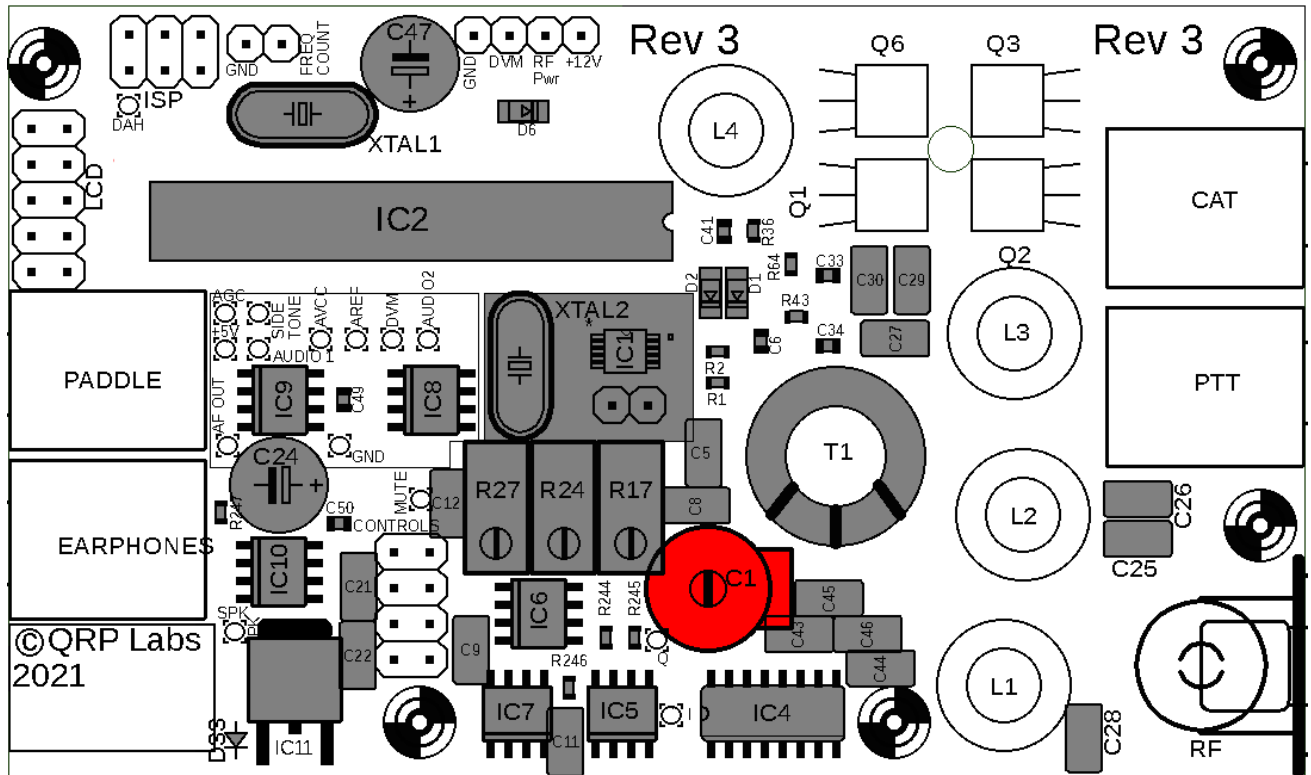

3.19 Install MPS751 transistor Q6

Be careful to correctly identify this transistor by its markings, as the package style is similar to the other transistors. Carefully bend and insert the wires so that the transistor's flat side is flat flush against the PCB surface, and the body of the transistor is aligned with the square on the layout diagram (which is not visible on the PCB silkscreen). The corner of the transistor should not overlap the PCB hole.

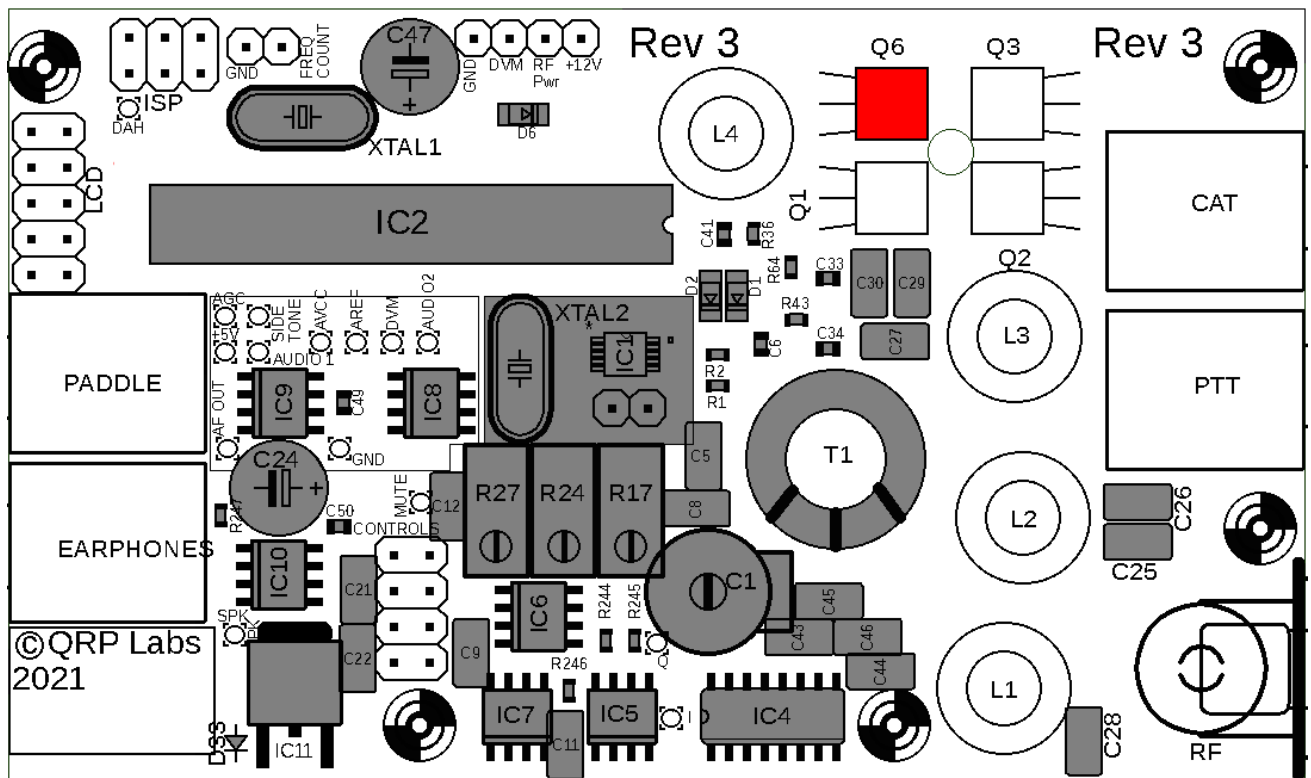
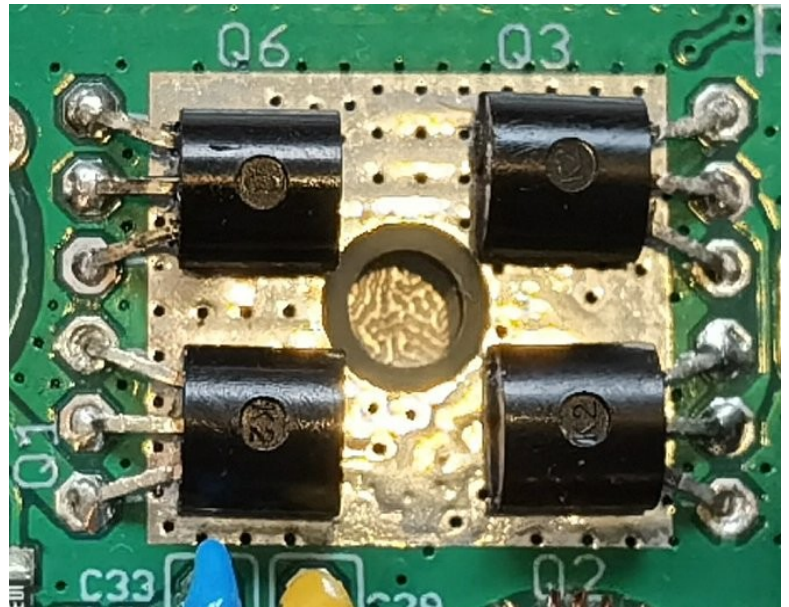

3.20 Install three BS170 transistors

The remaining three transistors in the kit are BS170 MOSFETs: Q1, Q2 and Q3

For Q1, Q2 and Q3, carefully follow the same installation procedure as the previous section, making sure that the transistors are neatly aligned in the correct positions near the hole in the PCB.

After installation, use the supplied 10mm M3 steel screw, 12mm steel washer and M3 nut to bolt the transistors' flat sides firmly flat on the PCB surface, as shown (photo, right).

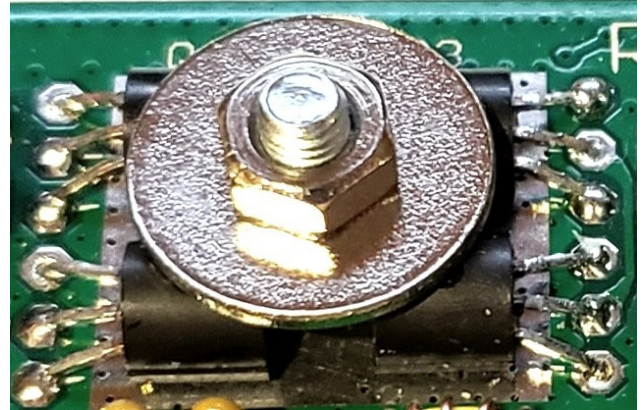

The kit may contain both a 10mm screw AND a 12mm screw. It is essential to use the 10mm screw, not the 12mm screw (which is too tall). 10mm is the desired length of the threaded section.

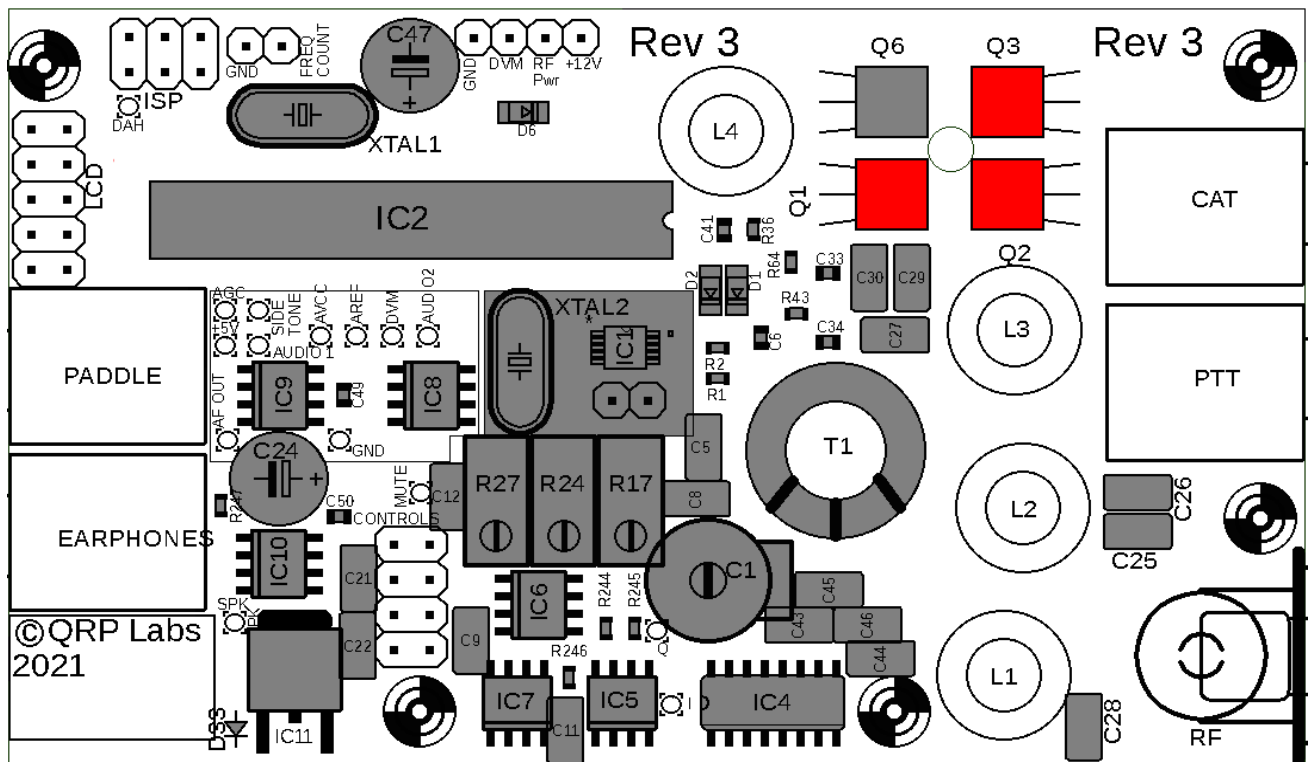

3.21 Install 2x3-pin in-circuit programming header

This male pin header can be used to connect an AVR Programmer to apply firmware updates if desired. Insert the SHORT end of the pins into the PCB. Solder one pin in place first and check that the header is nicely seated on the PCB before soldering the other 5.

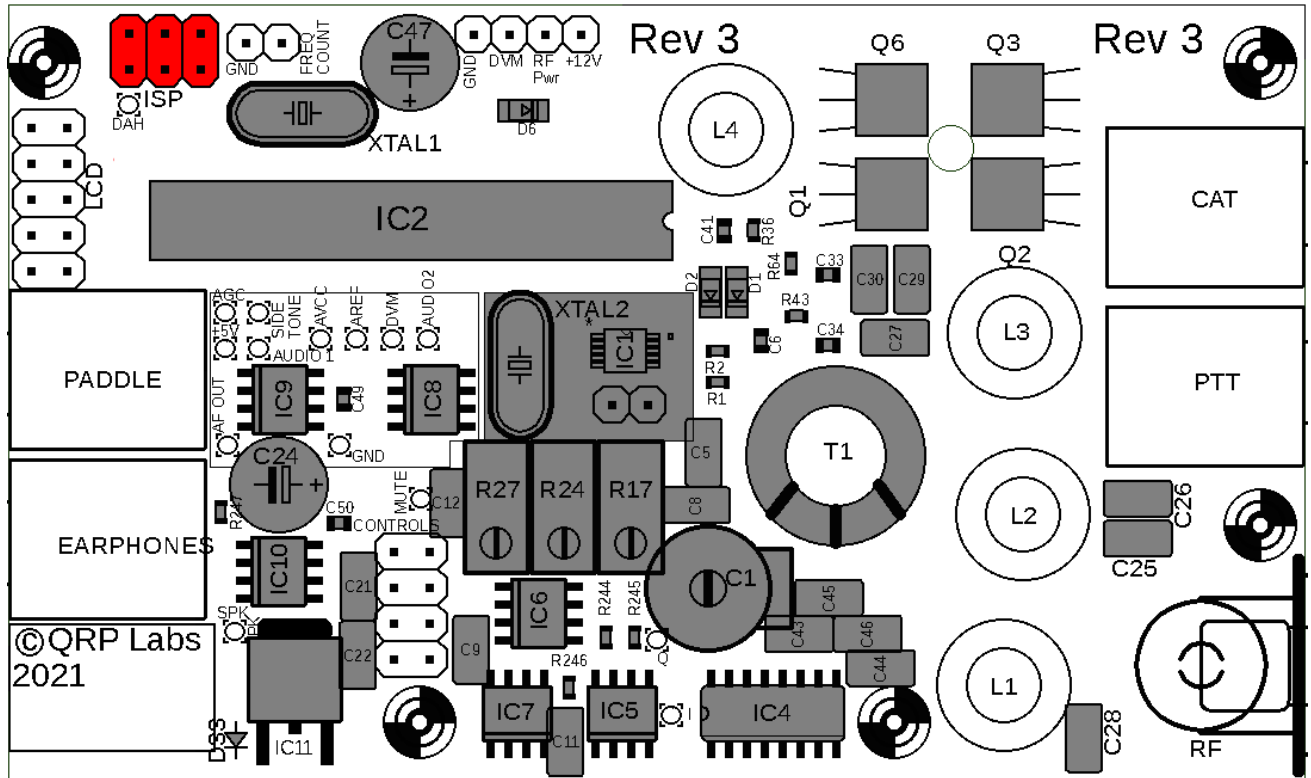

3.22 Install 2x5 LCD header

This female pin header (socket) connects the main QCX-mini PCB to the display board above it. Solder one pin in place first and check that the header is nicely seated on the PCB before soldering the other 9.

Be sure to install the 2x5-pin FEMALE pin header connector (see right), not the male header connector which is installed on the LCD board.

Try to hold the socket as far towards the top side of the board (in the diagram below) as possible, that is, as far away from the Paddle connector as possible. This is because installing the earphones and paddle connectors is a tight fit.

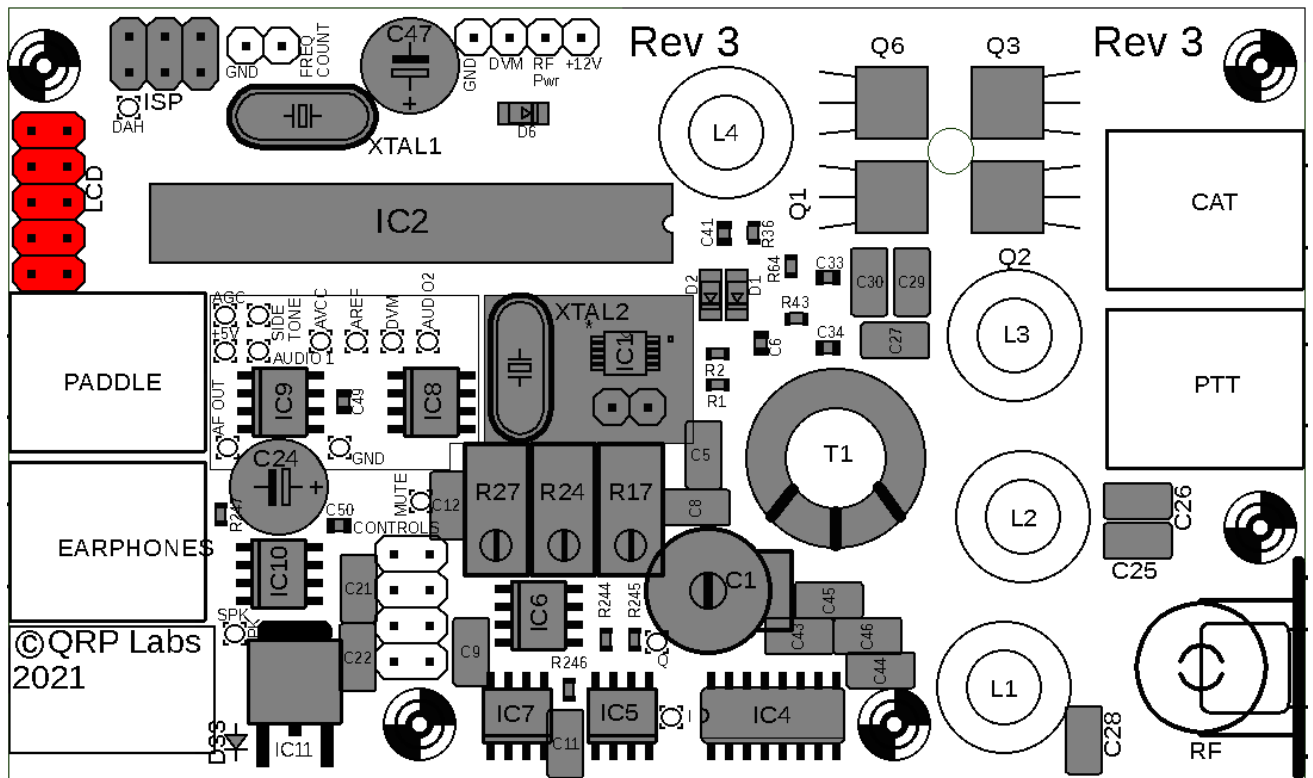

3.23 Install 2x4 UI header

This female pin header (socket) connects the main QCX-mini PCB to the controls board above it. Solder one pin in place first and check that the header is nicely seated on the PCB before soldering the other 8.

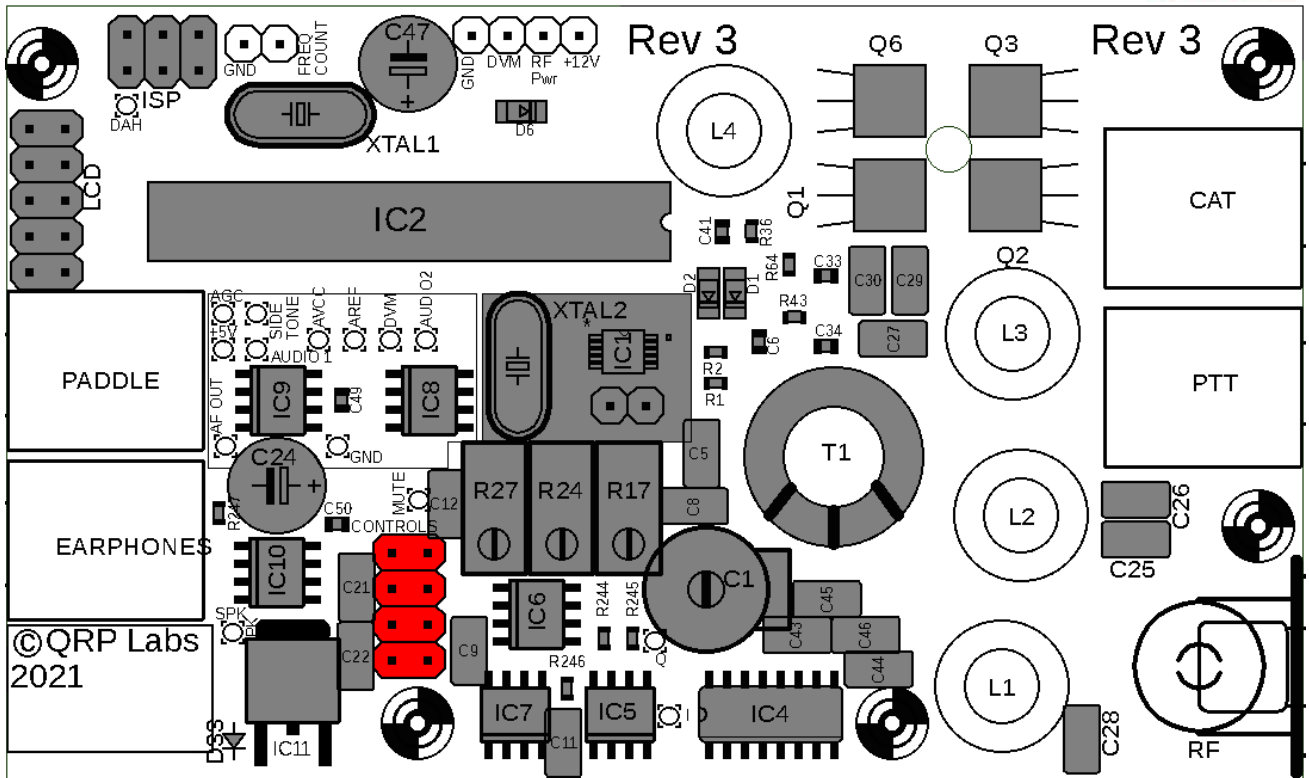

3.24 Wind and install toroid L4

L4 is type T37-2. It is a small ring with red paint on one side. Each time the wire passes through the hole in the middle of the toroid, this counts as one turn. The number of turns depends on the band of your kit, refer to the following table. Inductance values are approximate and will depend on variations in the core, and how tightly you wind the turns. Do not worry about these variations which are not critical in this case.

Band	Value	Turns
160m	1.4uH	19
80m	2.3uH	24
60m	2.3uH	24
40m	1.0uH	16
30m	0.78uH	14
20m	0.40uH	10
17m	0.32uH	9

Try to keep the wire quite tight (but not so tight that you break the wire). Try to spread the turns evenly around the toroid. Leave about 2cm or 3cm of wire at the ends.

The wire is coated with an enamel insulating paint and it is **CRITICAL** to remove this enamel at the soldered joints otherwise there will be no electrical connection through

the toroid! This is the number 1 cause of problems with QRP Labs kit construction: failure to remove the wire enamel.

One method of removing the wire enamel is to scrape it off at the ends, either with sandpaper, or carefully scratching with a knife or wire cutters. However, my favourite method is just to burn off the enamel. For quite a number of years, the type of enamel used on copper wire can be burnt off using the temperature available from an ordinary soldering iron, immersing the wire in a blob of solder. (This was not the case, with much older wire found in vintage valve/tube equipment). You could also use a cigarette lighter to burn off the enamel.

Insert the ends of the wires into the correct holes of the PCB and pull it through tight, so that the toroid sits secure and flat on the PCB.

Bend the wires over so that the toroid does not fall out while you are trying to solder the wires. Cut off the excess wire using wire cutters, leaving only about 2mm protruding through the PCB on the lower side. Now apply solder quite generously from the soldering iron. Hold the soldering iron to the joint for a few seconds – I usually count to 10 slowly – and the solder will surround the wire, which will become hot enough to burn off the enamel. You can sometimes see a small puff of smoke when the enamel burns off.

Carefully inspect the soldered joints with a magnifying glass to make sure that the wire is correctly soldered. If it looks like the solder hasn't flowed nicely and adhered to the wire, then this is usually a sign that the enamel probably hasn't been burnt off.

If you have a DVM it is a good idea to check for DC electrical continuity (zero ohms resistance) between the two ends of the wire. If you do NOT have a DVM and if the radio doesn't work, then we can use the built-in test equipment later, to trace the fault.

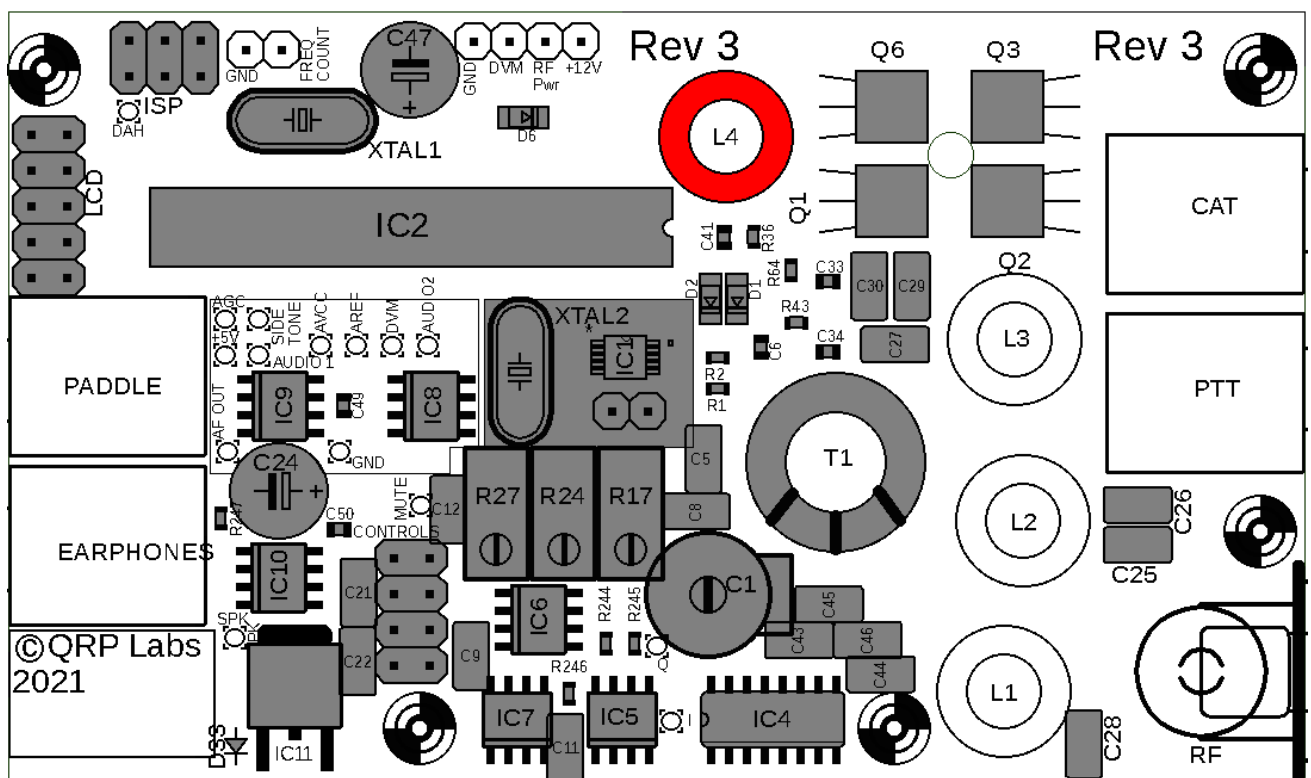

3.25 Wind and install toroid L2

L2 is a small toroid ring painted yellow or red on one side. It is part of the supplied Low Pass Filter kit bag. Installation of the inductor is similar to the previous section. **Remember to remove the wire enamel and check!**

In the QCX-mini kit, there is some advantage to winding the toroid with the turns tightly squeezed together, then installing it, and only then spreading them out evenly. This is because you will probably later want to try squeezing and expanding the turns of the toroids to optimize output power. The way the toroids are installed laying flat on the PCB in the QCX-mini, it's much easier to spread out the turns if they were initially bunched together, than it would be to bunch them up if they were initially spread out. In the latter case the wire will be rather tight to try and bunch up the turns.

The number of turns is band-dependent, refer to the following table. Inductance values are approximate and will depend on variations in the core, and how tightly you wind the turns. Do not worry about these variations which are not critical in this case.

Band	Toroid	Colour	Value	Turns
160m	T37-2	Red	6.4uH	40
80m	T37-2	Red	3.0uH	27
60m	T37-2	Red	2.3uH	24
40m	T37-6	Yellow	1.7uH	24
30m	T37-6	Yellow	1.3uH	20
20m	T37-6	Yellow	0.90uH	17
17m	T37-6	Yellow	0.67uH	15

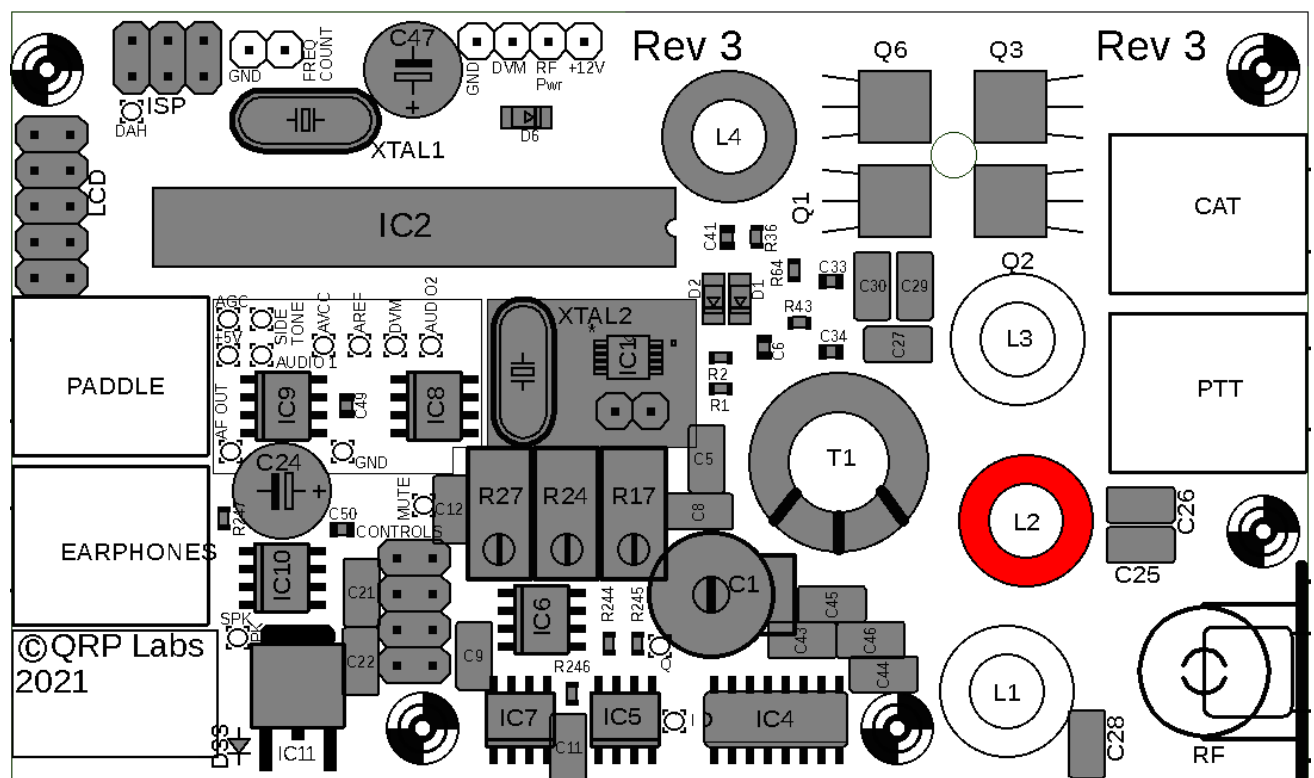

3.26 Wind and install toroids L1 and L3

L1 and L3 are small toroid rings painted yellow or red on one side. They are part of the supplied Low Pass Filter kit bag. Installation of the inductors is similar to the previous section. **Remember to remove the wire enamel and check!**

The number of turns is band-dependent, refer to the following table. Inductance values are approximate and will depend on variations in the core, and how tightly you wind the turns. Do not worry about these variations which are not critical in this case.

Band	Toroid	Colour	Value	Turns
160m	T37-2	Red	3.9uH	30
80m	T37-2	Red	2.4uH	25
60m	T37-2	Red	2.1uH	23
40m	T37-6	Yellow	1.4uH	21
30m	T37-6	Yellow	1.1uH	19
20m	T37-6	Yellow	0.77uH	16
17m	T37-6	Yellow	0.55uH	13

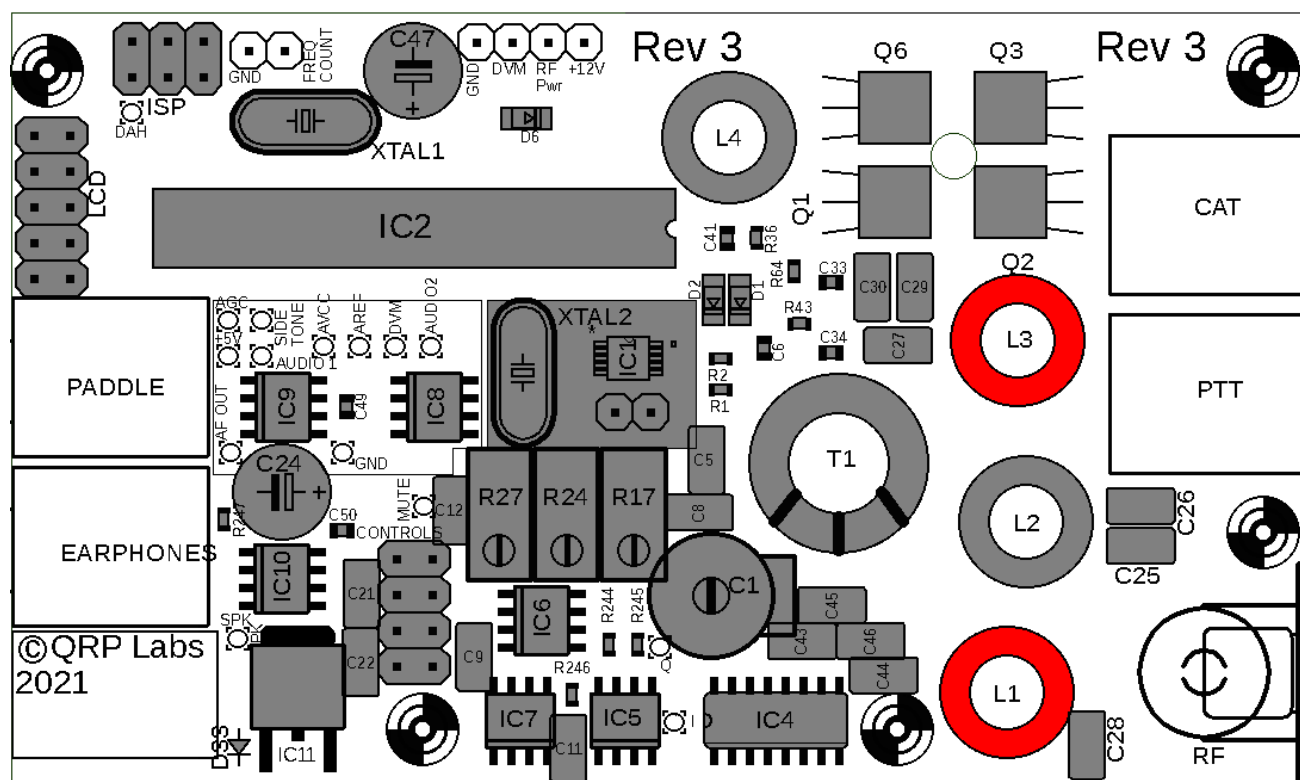

3.27 Install 2.1mm power connector

Install the 2.1mm power connector, orientated to match the PCB silkscreen. It is important to install this accurately so that if you install the QCX-mini in the optional aluminium enclosure, the connector is correctly aligned with the associated panel hole.

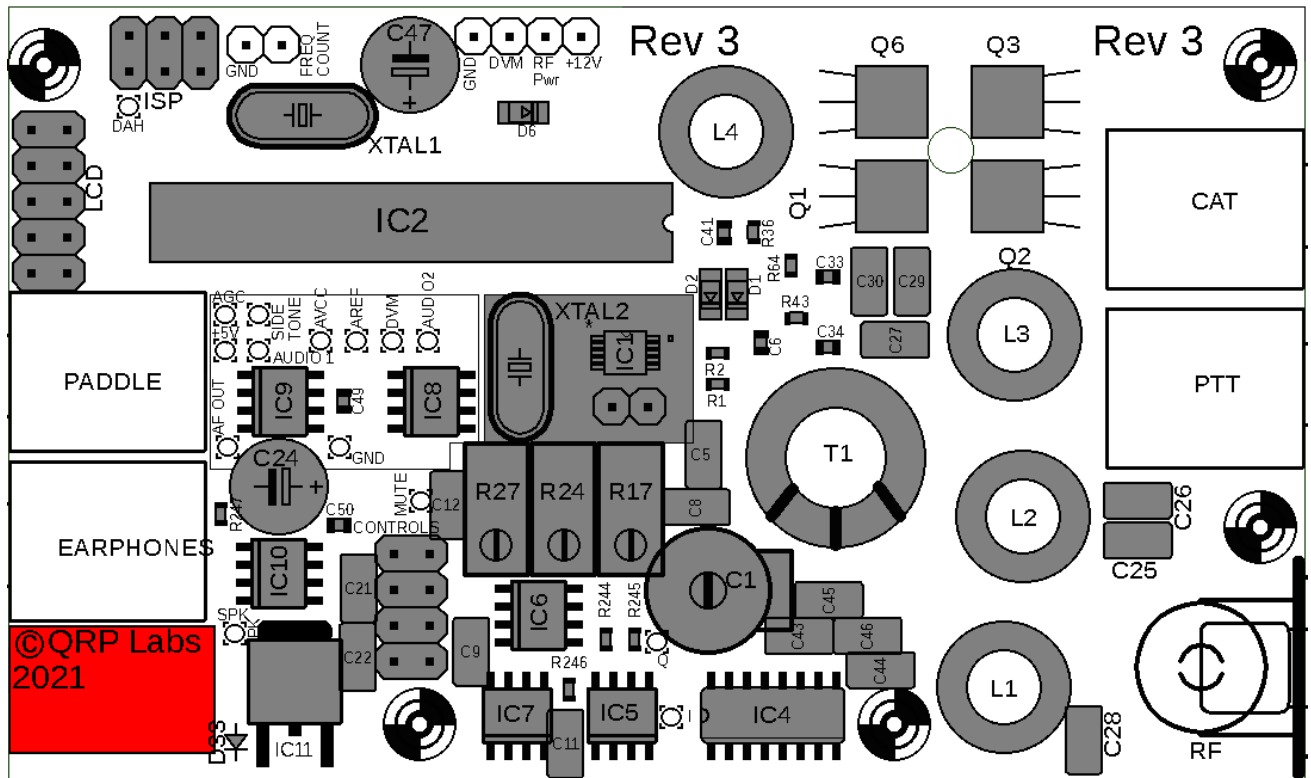

3.28 Install RF output BNC connector

An alternative is installation of a right-angled SMA connector here (not supplied).

Solder the center pin first, to check that the alignment is correct; when happy, proceed to solder the remaining pins. It is easier to ensure good alignment if the washer and nut are removed prior to installation.

Accurate alignment is very important, to ensure that the connector fits into the hole of the optional QRP Labs QCX-mini enclosure (if used). The rim on the connector body should not overlap the edge of the PCB. The BNC connector must sit squarely on the board with the metal body extending at 90-degrees to the PCB edge. Cut the excess wire length of the center pin after soldering.

The metal body of the BNC connector is directly cast to the four ground pins of the connector. Soldering these pins requires a lot of heat! Using a 60W soldering iron during prototype assembly, the iron was held to each pin of the connector for at least 20 seconds to heat it up fully and ensure a good electrical and mechanical bond.

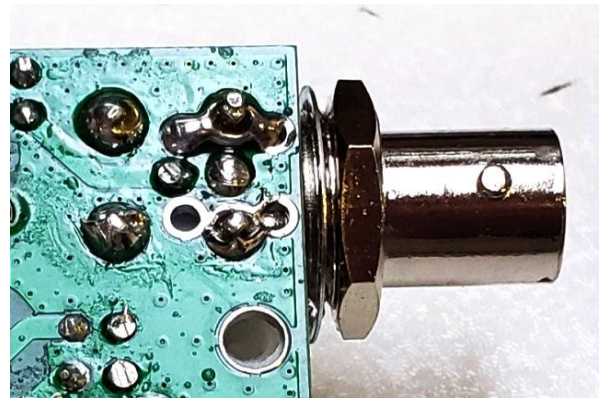

It needs a lot of heat, some time, and a lot of solder... Do not worry if you create solder bridges to the ground pads which are available optionally for the SMA connector; but do make sure that there are no short-circuits to the center pin!

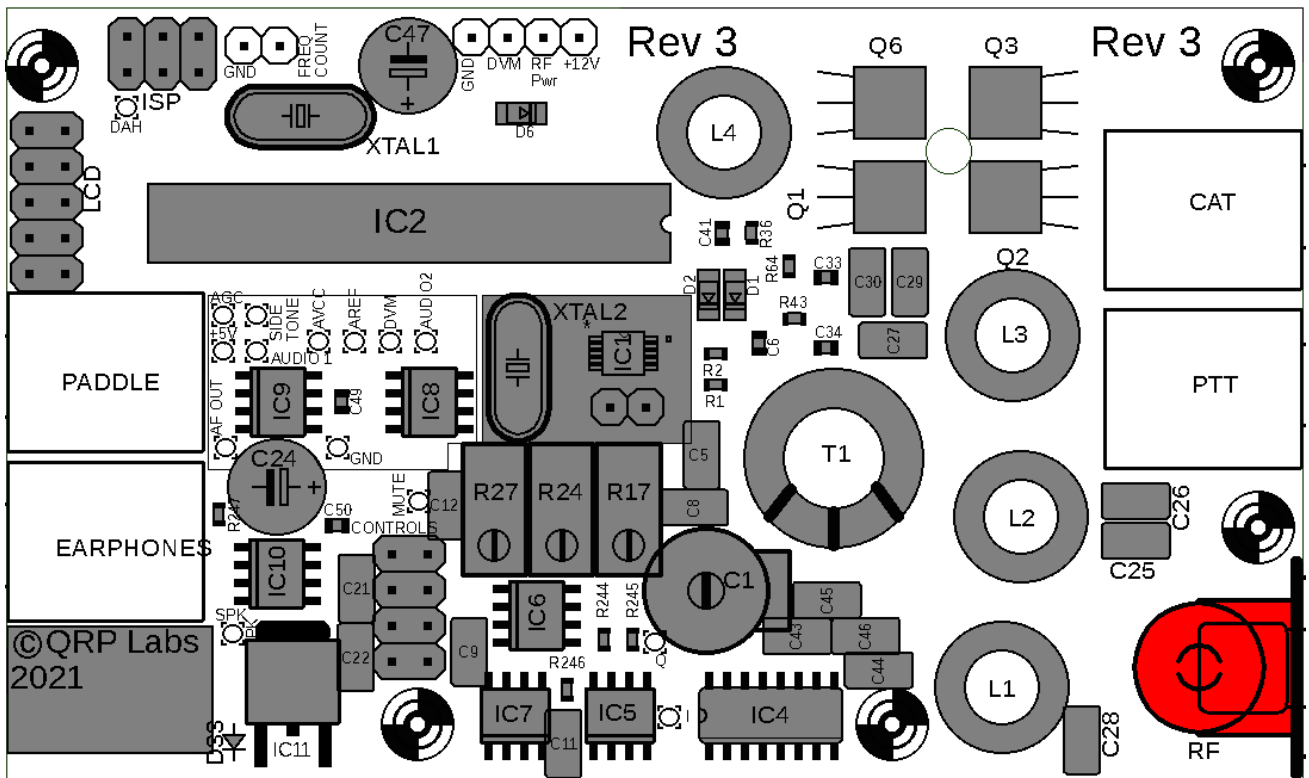

3.29 Install 3.5mm stereo jack connectors

This is the final step in the assembly of the main board. There are four stereo 3.5mm jack connectors, used for the audio output (earphones), optional connection of a paddle, optional CAT connection, and optional PTT output to 50W PA kit (optional QRP Labs kit).

Accurate alignment is very important, to ensure that the connectors fit into the holes of the optional QRP Labs QCX-mini enclosure (if used). The connectors have a tendency to sit at a crooked angle. This must be corrected. One way to ensure precise positioning is to angle some solder a few cm above the workbench, then hold the board in one hand, pushing firmly to straighten the connector, then solder the ground tab (the tab nearest the PCB edge). Next, solder a tab near the inside of the PCB area; then check the alignment again before continuing with the remaining three pins (photo 1 shows PTT and CAT; Photo 2 Audio and Paddle connectors).

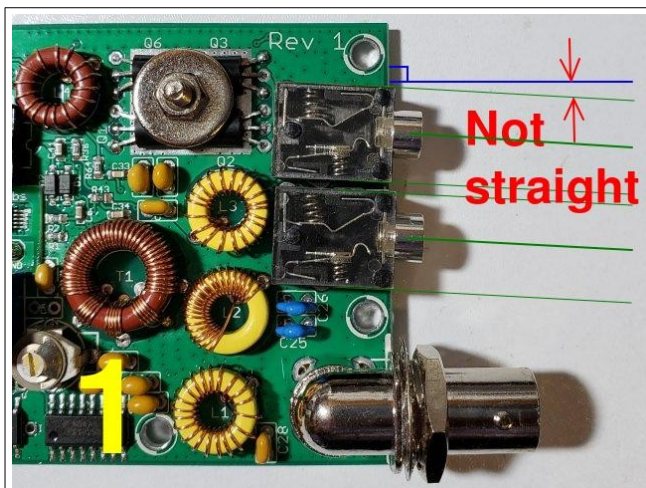

A tendency to sit at a crooked angle...

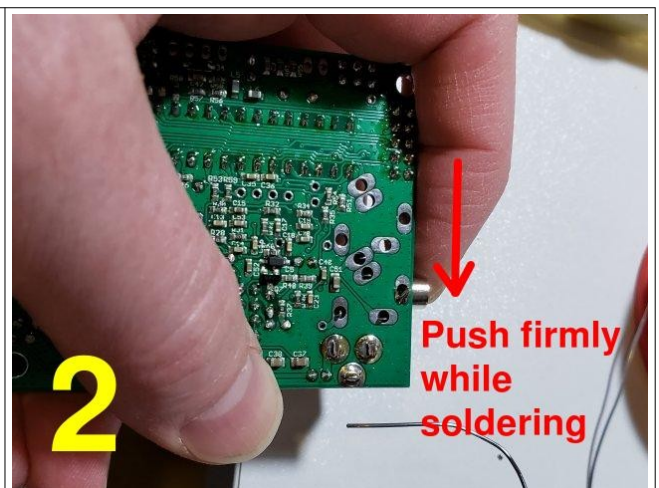

...push firmly during soldering to correct this

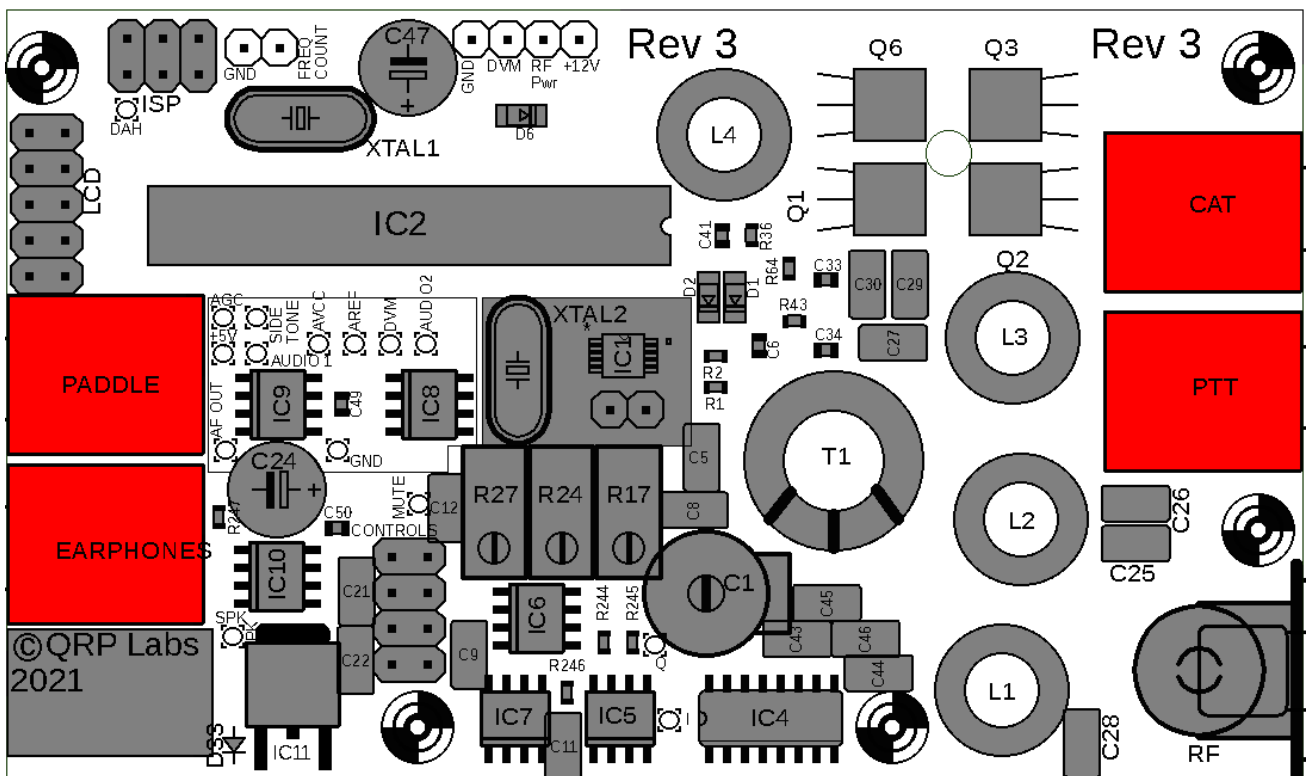

3.30 Break apart inner PCBs of display board

Now that the main PCB assembly is complete, the display board and controls board are assembled next.

The display board panel contains several smaller PCBs which are joined to the display board via thin PCB bridges which have a line of holes, designed to be easily snapped out.

- Controls PCB: this will hold the gain control, rotary encoder (tuning) control and the two buttons.
- Controls board spacers: two tiny PCBs which are fit on the mounting points of the control PCB to increase its height above the main QCX-mini PCB by 1.6mm
- uSDX daughtercard: the PCB for the SSB modification supported by the uSDX group <https://groups.io/g/ucx>

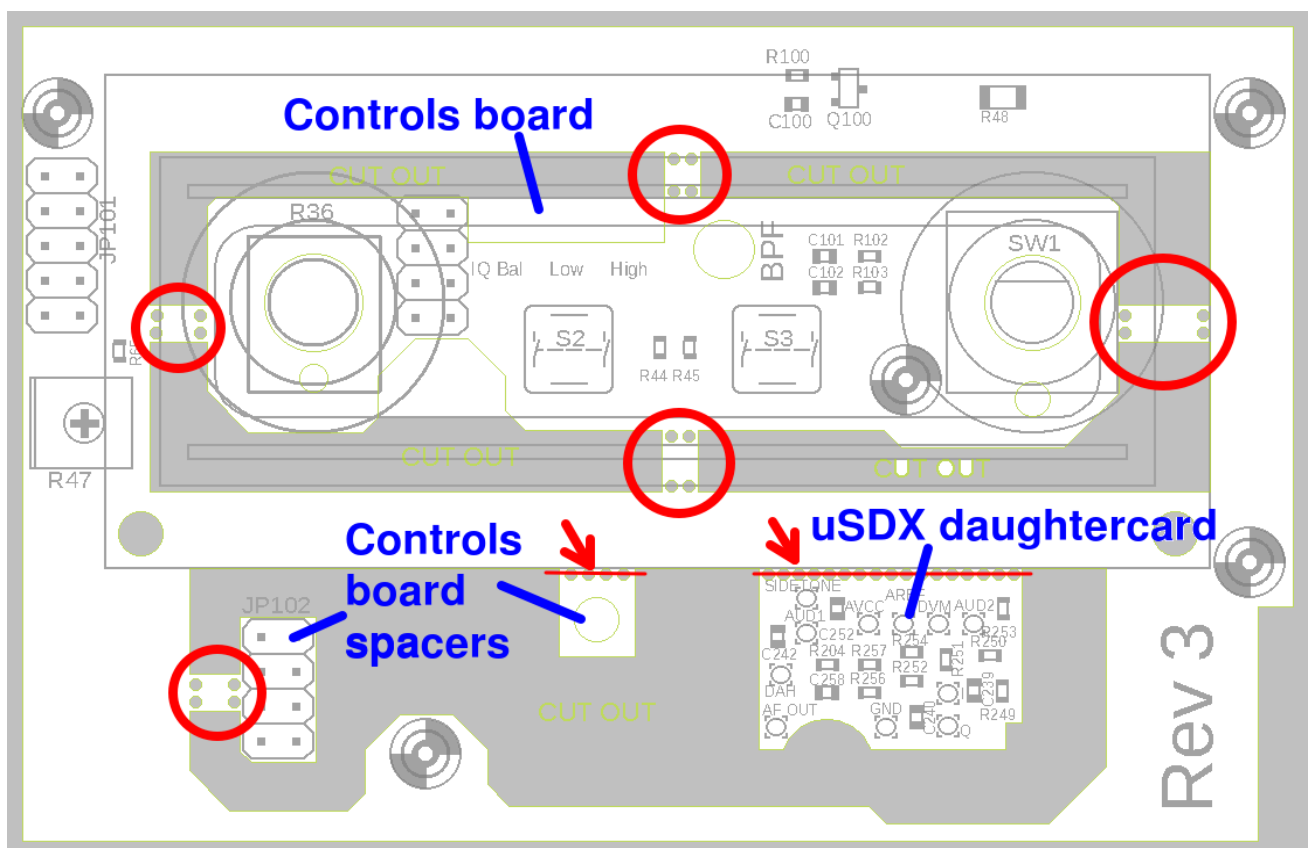

The small PCBs can be snapped out of the panel using needle-nosed pliers or wire cutters or some such similar tool. Breaking out the controls board is easiest, just a twisting action while gripping the thin PCB bridge is enough to break it out. The uSDX daughtercard and control board spacers require a bit more care; particularly the uSDX daughtercard, be careful not to break the main center spar of the display board while snapping it off.

Once removed, it is essential to file the rough edges of all the PCBs (except the uSDX daughtercard – it is only necessary to file this one if you are intending to use it).

The Controls board has to fit through the hole in the lower part of the display board and will not do so unless the rough edges have been smoothed off!

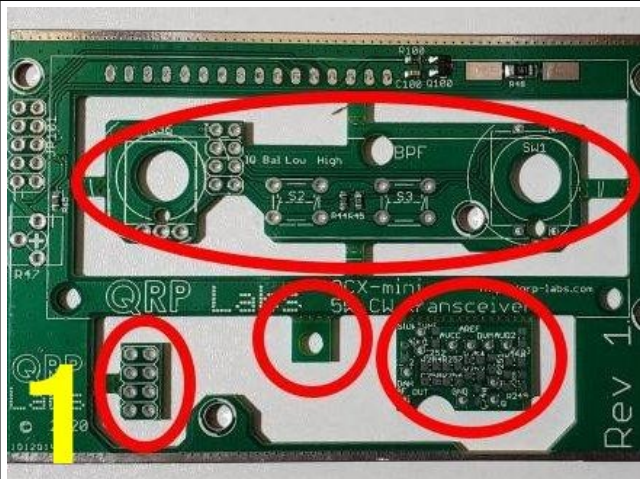

1 Location of five small PCBs to snap out of the display board panel

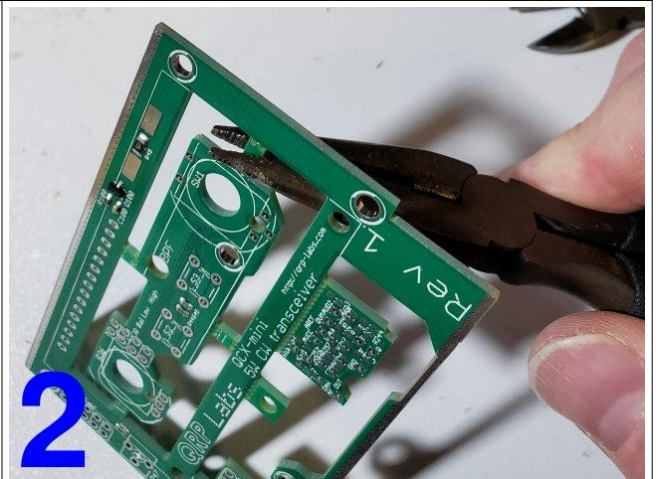

2 Squeeze and twist the PCB bridge to snap out using pliers or wire cutter

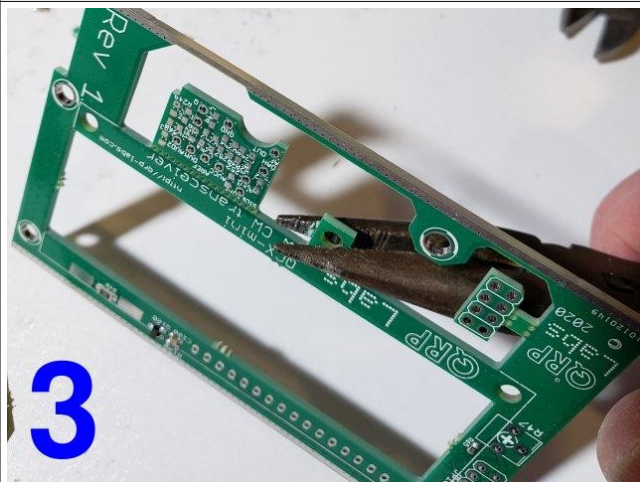

3 Gently grip and bend to remove – but be careful of the central spar of the panel PCB

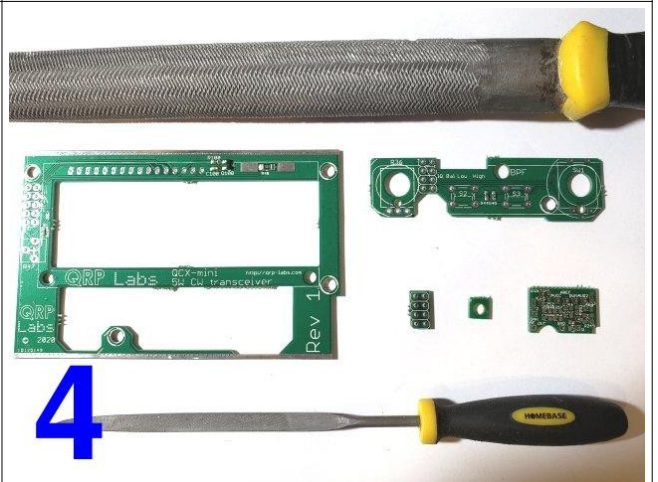

4 File rough edges of the cut-outs in the panel PCB and the broken-out pieces

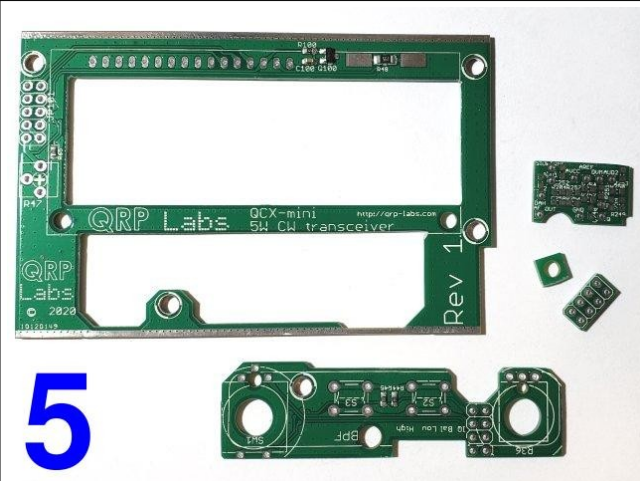

5 All five parts after careful filing

3.31 Install LCD module

Precision assembly is essential – follow the guide below carefully.



Identify the pairs of M3 6mm screws and nuts. They may be nylon or metal.

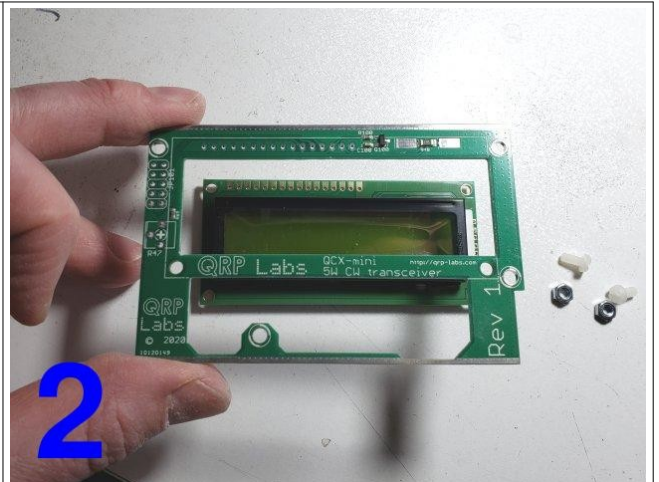

Fit the LCD module from behind the PCB, with its body through the rectangular cut-out

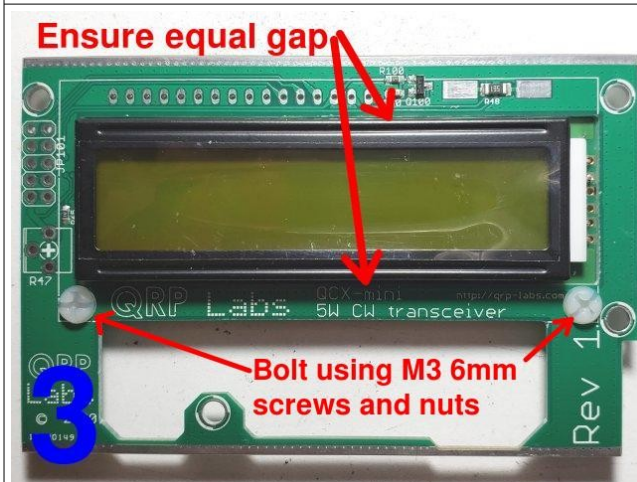

Bolt the LCD module, ensuring equal gaps at top and bottom; tighten screws firmly.

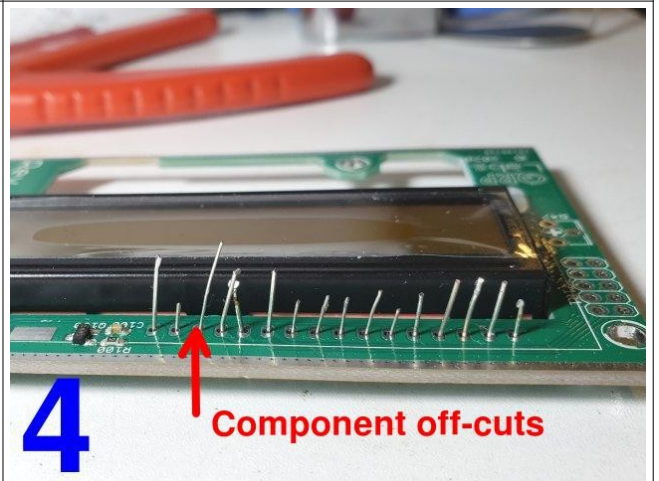

Drop component off-cuts through the 16 holes, their bottom ends sitting on the bench

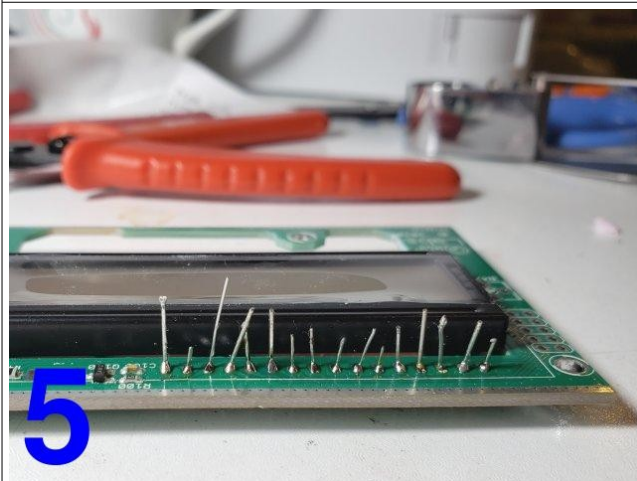

Solder the component off-cut wires to the top of the PCB and trim (cut) the excess wire

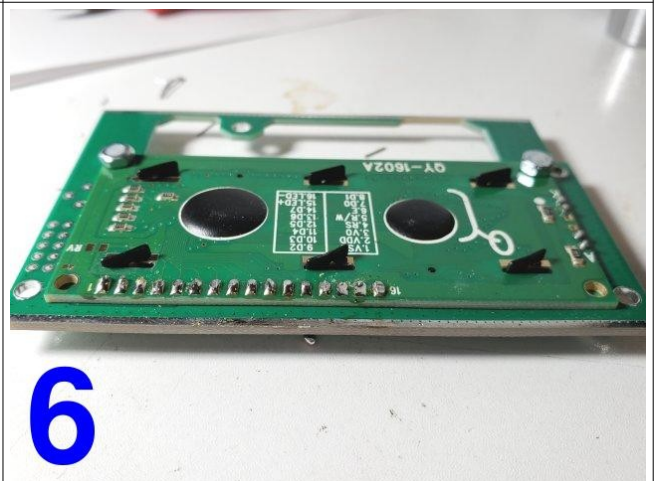

Turn over the PCB. Ensure the LCD sits flat on the PCB before soldering; trim excess. Cut these wires VERY short to avoid touching components on the main PCB later.

3.32 Install 2x5-pin male pin header connector

Install the 2x5-pin male header from below the display PCB; the short-end of the pins should be inserted through the PCB from the bottom side, as shown.

Solder one pin first, and check alignment before continuing with the other nine. Try to ensure that the pin header sits squarely and centrally in its allocated position.

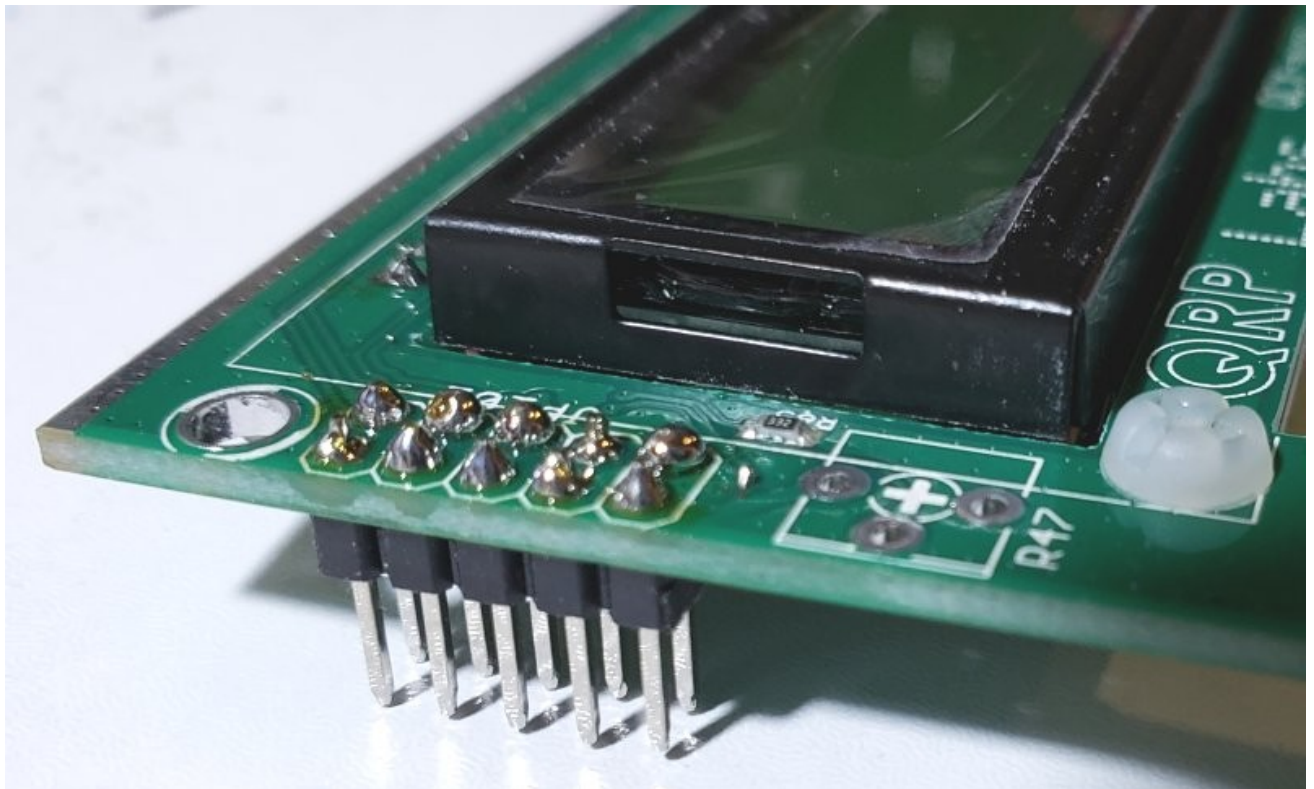

3.33 Install four 11mm nylon spacers

Install four 11mm nylon hex spacers on the underside of the LCD PCB using four 6mm nylon screws as shown.

Ensure the hex spacers are positioned such that a flat side is parallel to the nearby PCB edge, so that no corners overhang the edge of the PCB, which would prevent the enclosure end panels fitting.

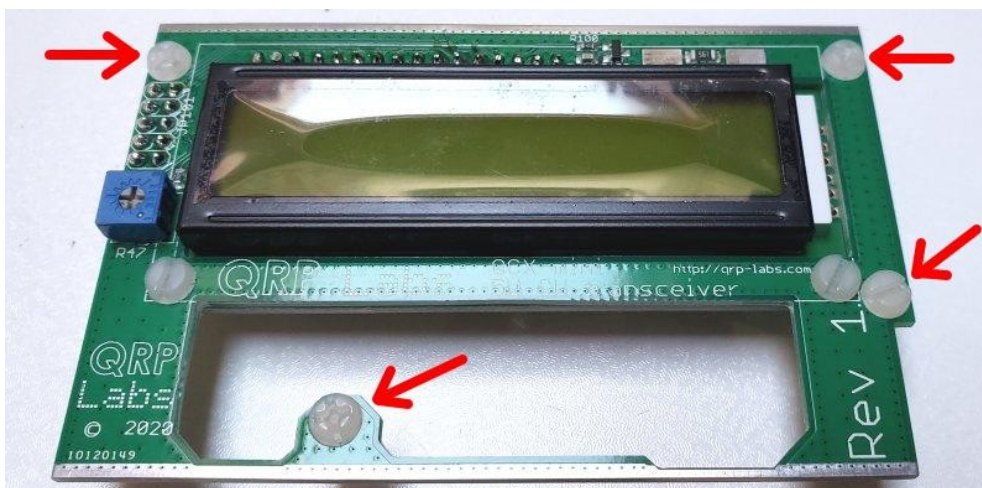
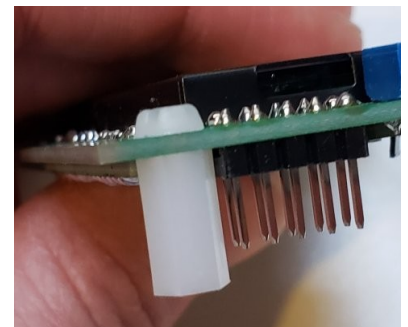

3.34 Install 20K trimmer potentiometer R47

The 20K single-turn trimmer potentiometer allows adjustment of the LCD contrast.

This potentiometer, similar to the 24-turn trimmer potentiometers installed on the main QCX-mini PCB, has four little feet, one in each corner. Unfortunately these make the trimmer too high and it may prevent the PCB from sliding into the QCX-mini enclosure later. Therefore it is necessary to cut off the protruding feet using a wire cutter, so that the potentiometer can sit flat on the PCB.

Follow the steps below to install this part.

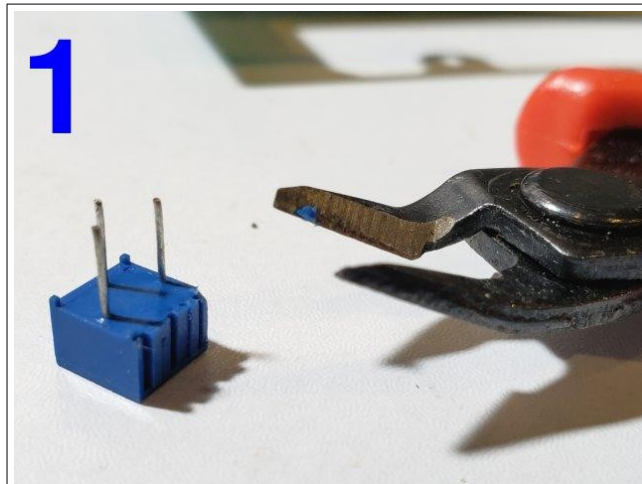

1 Cut each little plastic foot using wire-cutters.



2 It doesn't matter if the corner of the potentiometer body is damaged slightly.

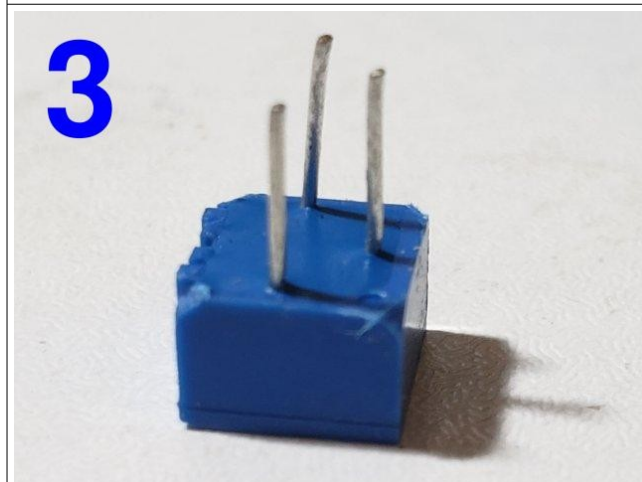

3 In the end it could look like this.

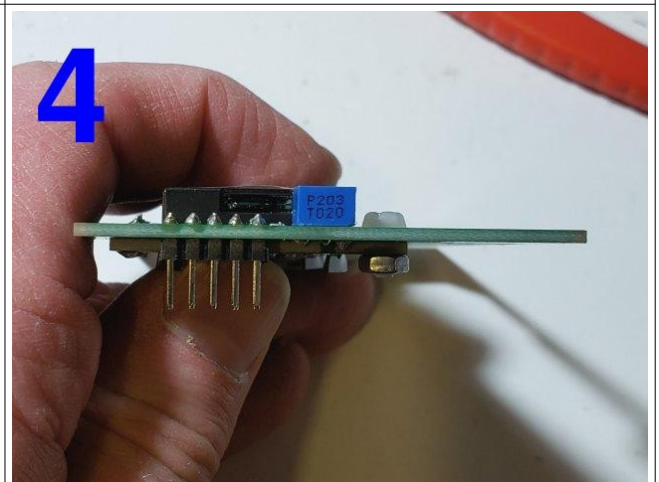

4 Install and solder, with the potentiometer body sitting flat on the PCB as shown. Trim excess pin length from the bottom side.

3.35 Install 2x4-pin male header on controls PCB

Next comes the assembly of the controls PCB, which holds the gain control, rotary encoder (frequency tuning), and the two tactile switch buttons.

If the header pins are LONG, as in the photo, right (around 16-17mm), then please use the steps on the [following page](#), not this page.

The 2x4-pin header must be installed with the small spacer PCB sandwiched between the connector body and the underside of the PCB. Carefully follow the steps below to install this part.

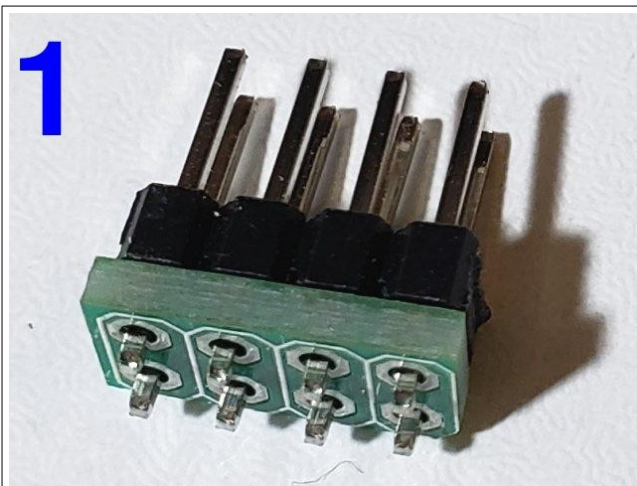

Thread the small spacer PCB having 8 matching holes, onto the short-pin side of the 2x4-pin header.

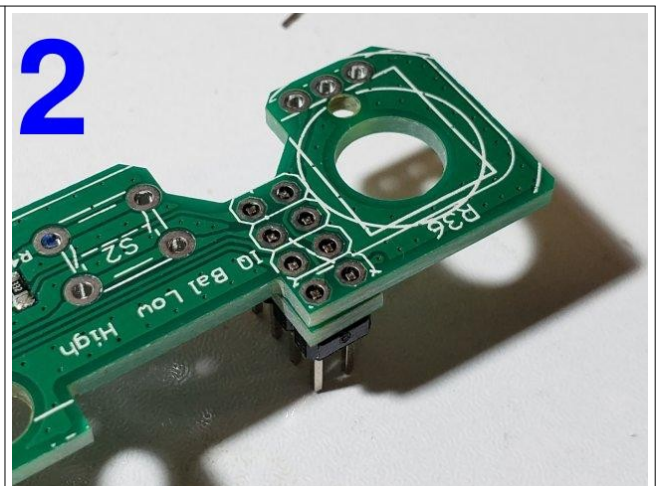

Insert the remaining length of the short pins into the PCB from the under-side, as shown.

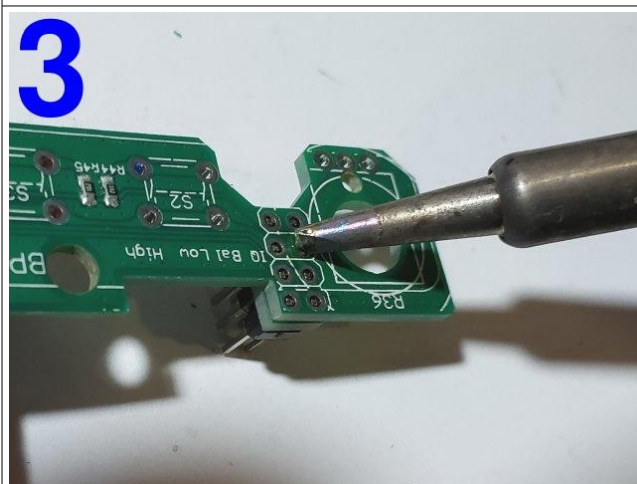

The pins don't protrude from the top side of the holes. However the holes are through-hole plated. Be generous with the solder, and apply heat to the hole for at least 5 seconds to ensure the solder flows down inside the hole and makes a good connection to the pin.

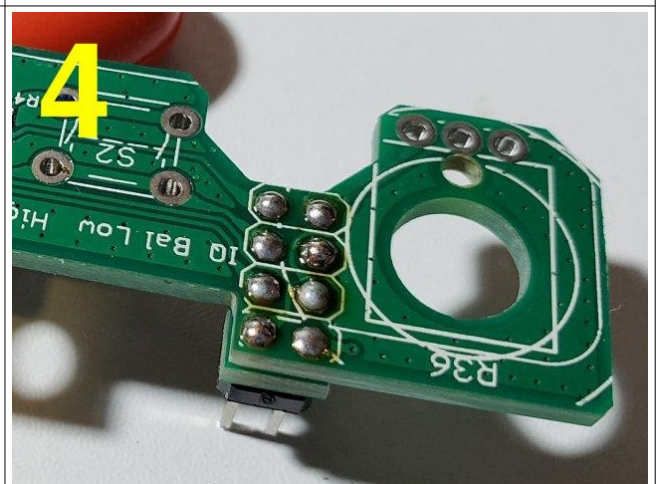

Likewise, solder the remaining seven pins. Don't worry, this method really does work reliably; just ensure the soldering iron is poked into the hole if possible and apply heat for at least 5 seconds on each joint, and plenty of solder.

On newer QCX-mini kits, the supplied 2x4-pin header has longer pins (about 17mm). This change was made, because the shorter pin headers were a little difficult to install with reliable connections, due to their short length; this was a cause of several construction issues.

The 2x4-pin header must be installed with the small spacer PCB (see photo, right) sandwiched between the connector body and the underside of the PCB. Carefully follow the steps below to install this part.

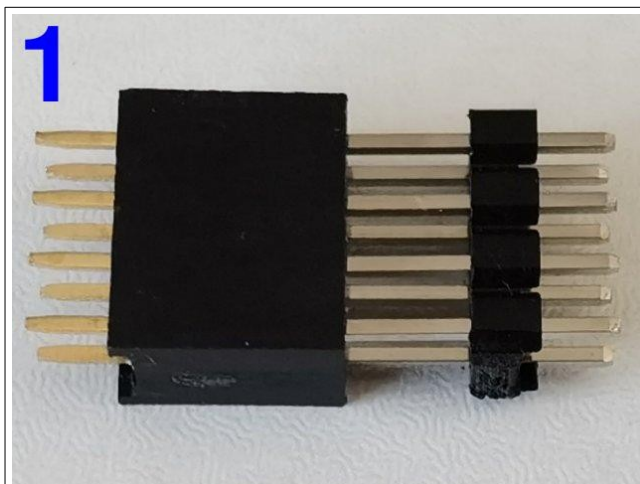

Insert the long pins into the 2x4-pin header socket (that will already be installed on the main QCX-mini PCB, in reality, but is shown separately here for clarity).

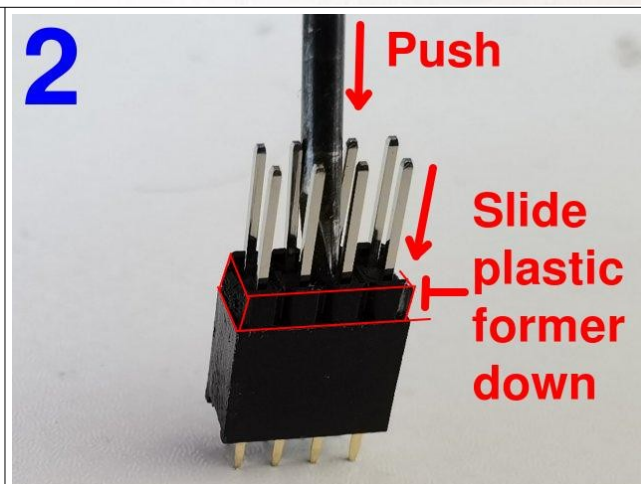

Use a screwdriver to firmly push down on the plastic former of the 2x4-pin header as shown, to slide it down the long pins until it sits flush on the 2x4-pin socket body.

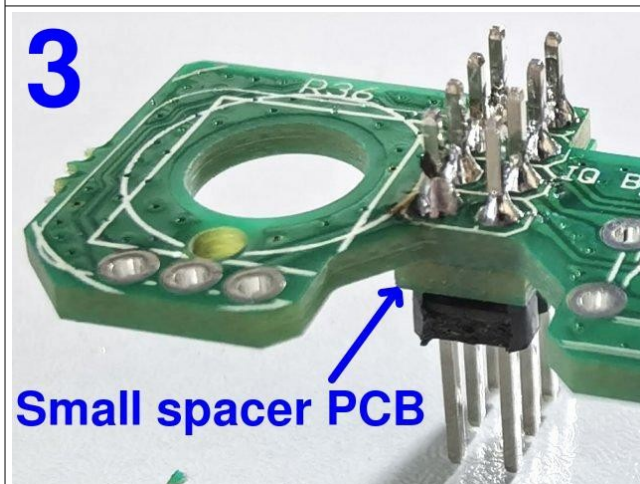

Thread the small spacer PCB onto the top side of the pins, and insert them into the controls PCB from below (silkscreen up, as shown), then solder carefully on the top side, ensuring no shorts. **The spacer PCB is important! Don't forget to install it!**

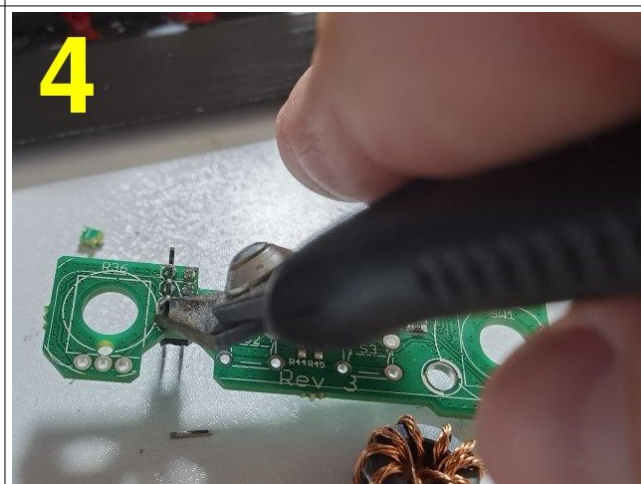

Use wire cutters to cut off the excess length of the long pin headers. They need to be trimmed otherwise they will risk touching the metal of the enclosure when the QCX-mini is installed in its enclosure.

3.36 Install rotary encoder

The rotary encoder is installed in the large hole labeled SW1 on the controls PCB.



1

First cut off two large PCB-mounting lugs as shown using wire-cutters. Do NOT cut pins.



2

Position a flat-headed screwdriver above one of the five switch pins.

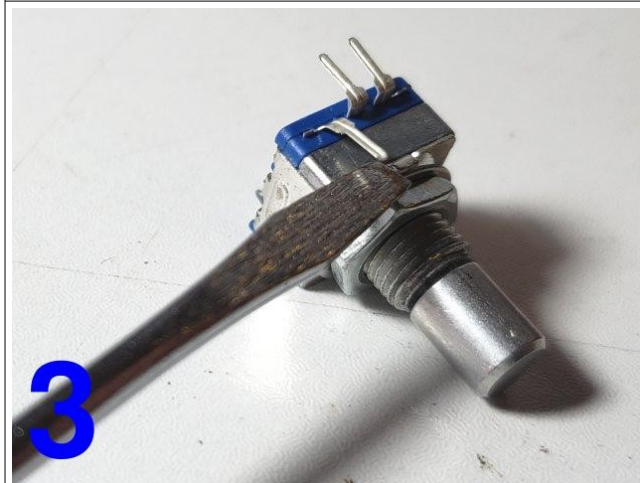

3

Bend over the pin through 180-degrees so that it points to the front of the control.

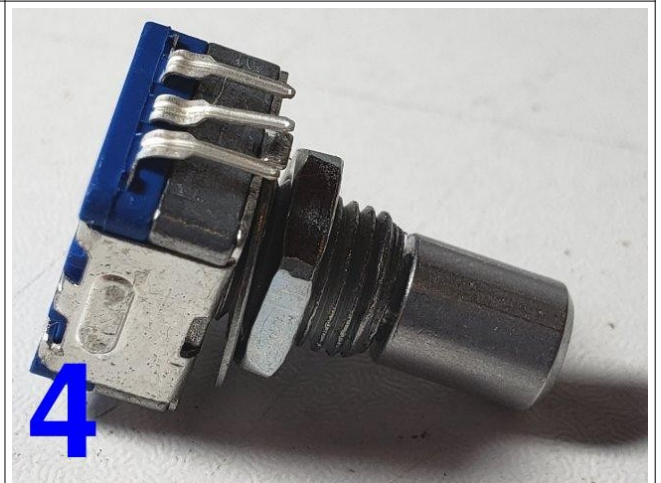

4

Repeat the same procedure for the four remaining pins.

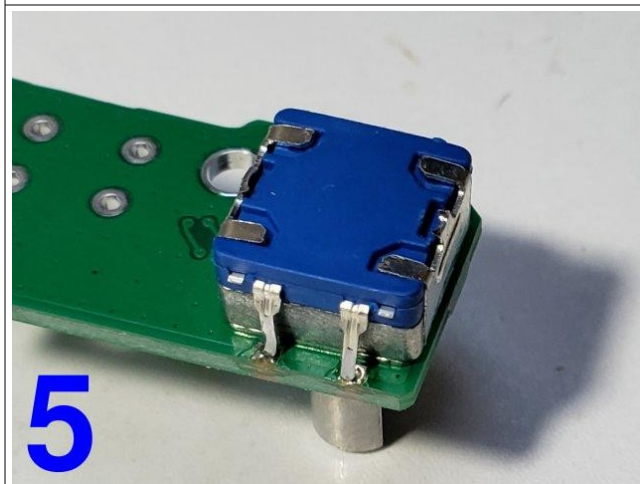

5

Install the rotary encoder, first line up pins so that they fit in corresponding PCB holes. The rotary encoder has a locating tab which fits into a matching hole on the PCB.

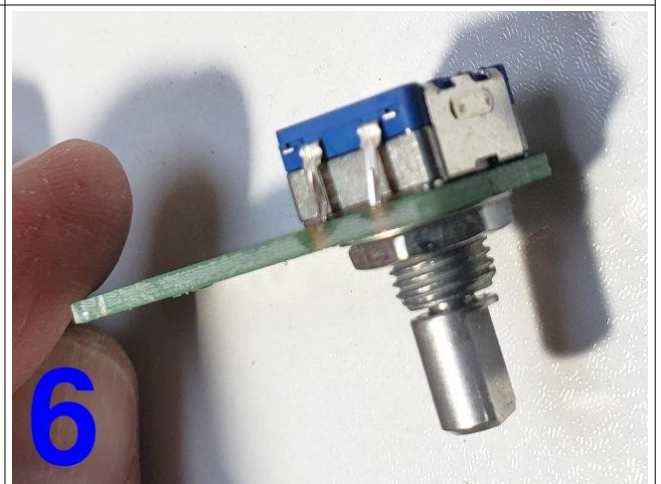

6

Make sure the nut is on the "top" (silk-screened) side of the PCB. Do not use the washer. Tighten the nut.

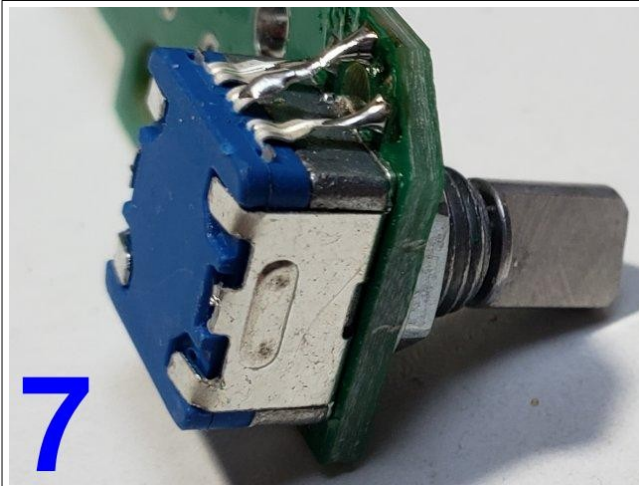

Solder each of the five switch pins, on the underside of the PCB (the side with the blue body of the rotary encoder). The center pin of the three may benefit from a piece of wire off-cut to extend it to reach the PCB hole.

3.37 Install tactile switch buttons

The two buttons should be installed on the control PCB as shown. These have four pins on a rectangular footprint that can only fit into the PCB one way. The only special precaution to observe here, is to make sure that the switch button is seated squarely on the PCB, so that the shaft is perpendicular to the PCB. Solder two diagonally opposite pins first then check the alignment and make any adjustments necessary; when all is well, solder the two remaining pins.

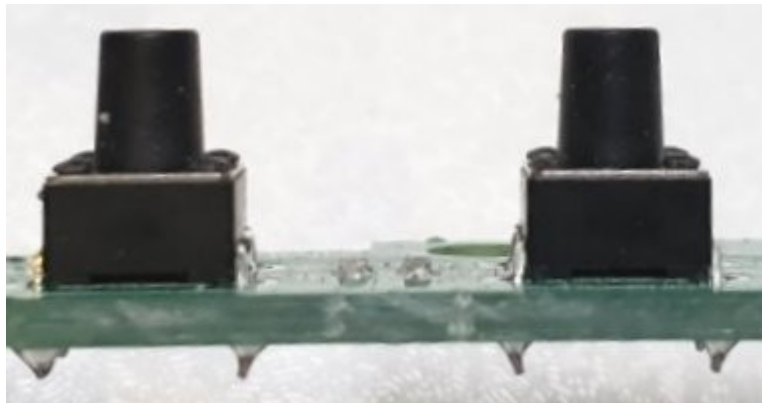

3.38 Install gain control potentiometer R36

Remove the nut and washer from the potentiometer shaft. Install the potentiometer into the position labeled R36. Align the potentiometer squarely with its locator tab in the provided hole in the PCB. Secure the potentiometer in place with the nut (do not use the washer), and tighten.

The pins of the potentiometer will not reach the PCB however much you bend them. Therefore it is necessary to bridge the gap between the pins and the PCB holes using component off-cut wires. Just keep the pins as they are, don't attempt to bend them.

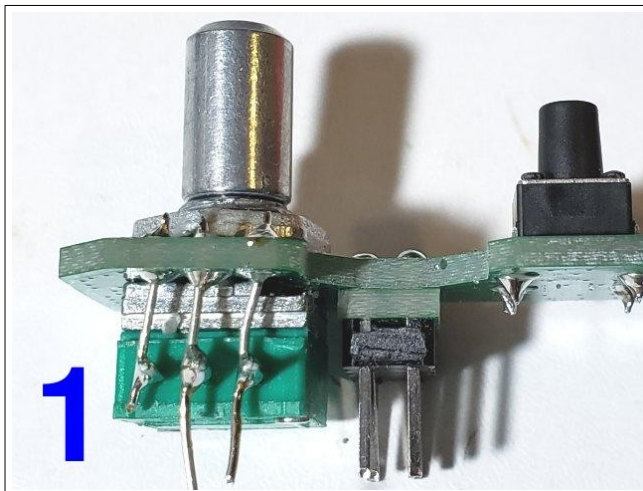

1 Install component off-cut wires, soldering first the PCB end then the potentiometer pin end; make the connection as close to the green potentiometer body as possible.

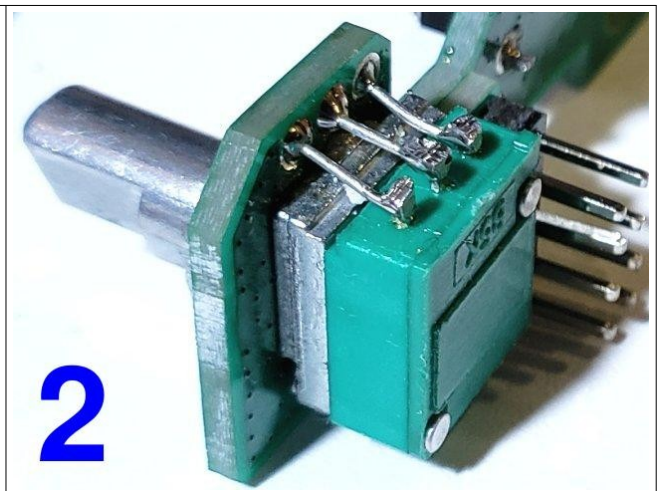

2 Trim any excess length of both the pins, and the off-cut component wires. It is important to trim these as close to the joint as possible so that there are no shorts when the boards are fitted into the enclosure.

3.39 Install 11mm nylon hex spacer

The final 11mm nylon hex spacer is bolted to the controls PCB using an M3 6mm nylon screw. Push the screw through the hole from the front side of the PCB. Thread the small square spacer PCB that was broken out from the Display PCB panel, onto the screw. Then screw on the 11mm nylon spacer.

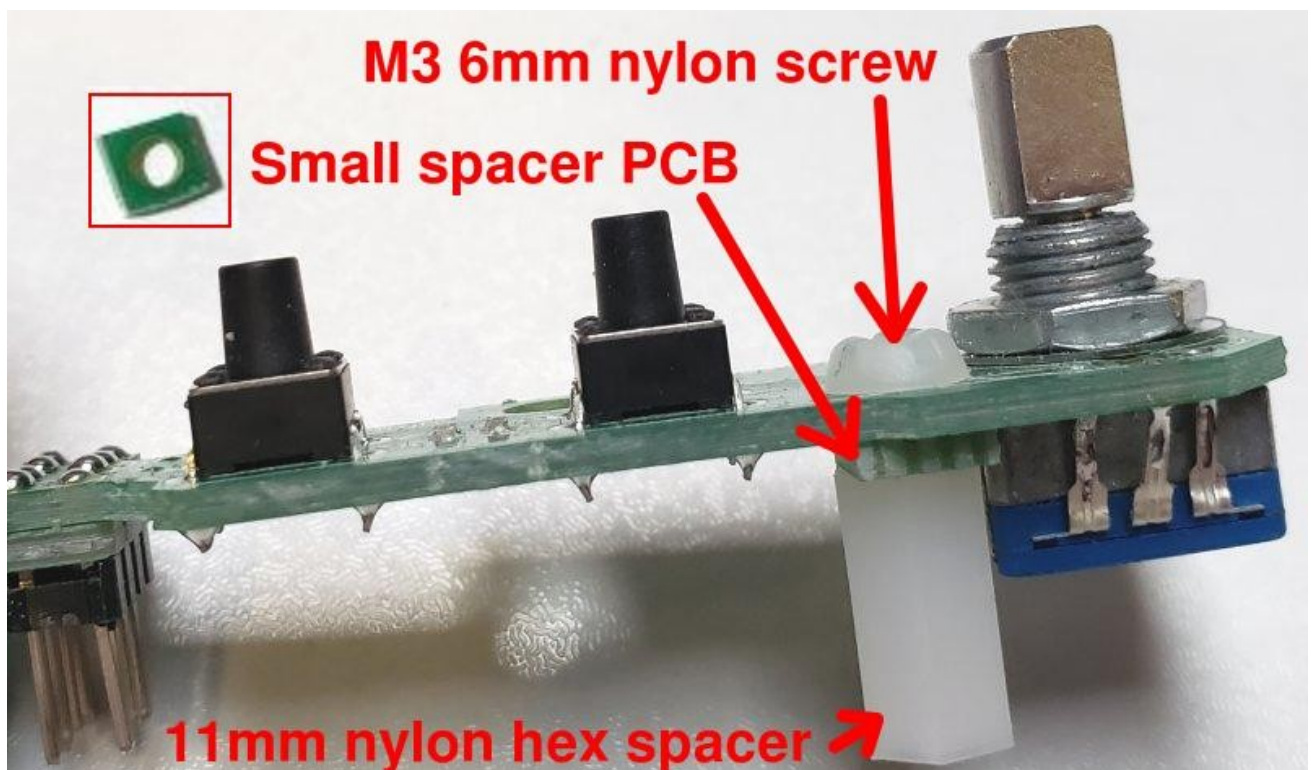

This completes the Controls PCB assembly.

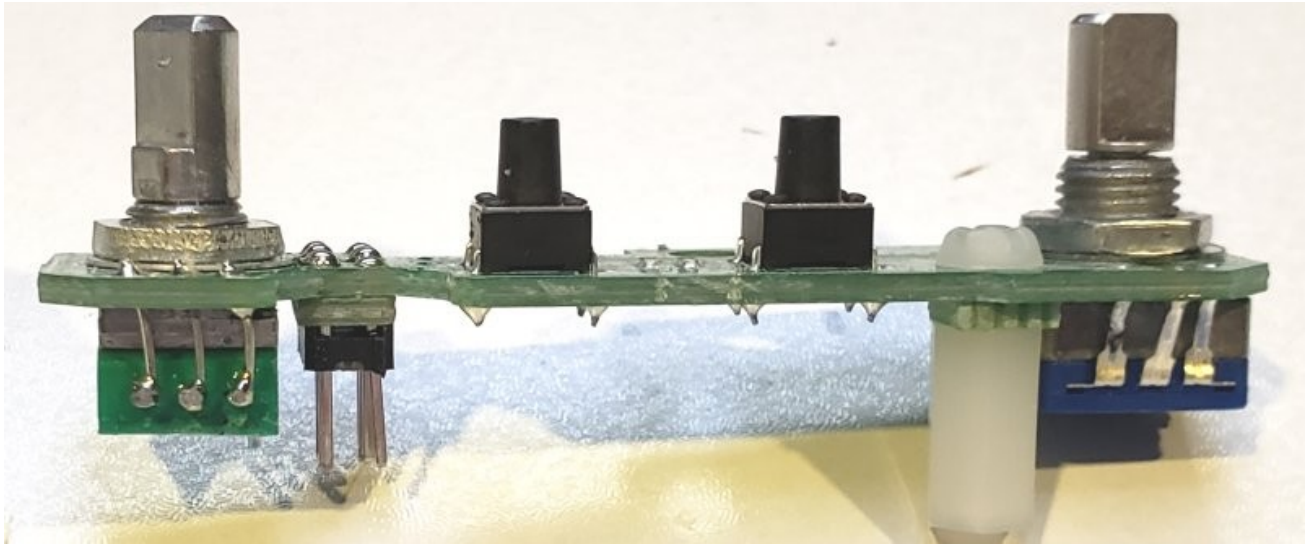

3.40 Fit Controls PCB to main PCB

Now fit the Controls PCB to the main PCB by plugging together the two 2x4-pin header connectors.

Fit an M3 6mm screw from the underside of the main PCB, screwed into the 11mm nylon hex spacer pillar that is fixed to the Controls PCB, as shown in the following photograph.

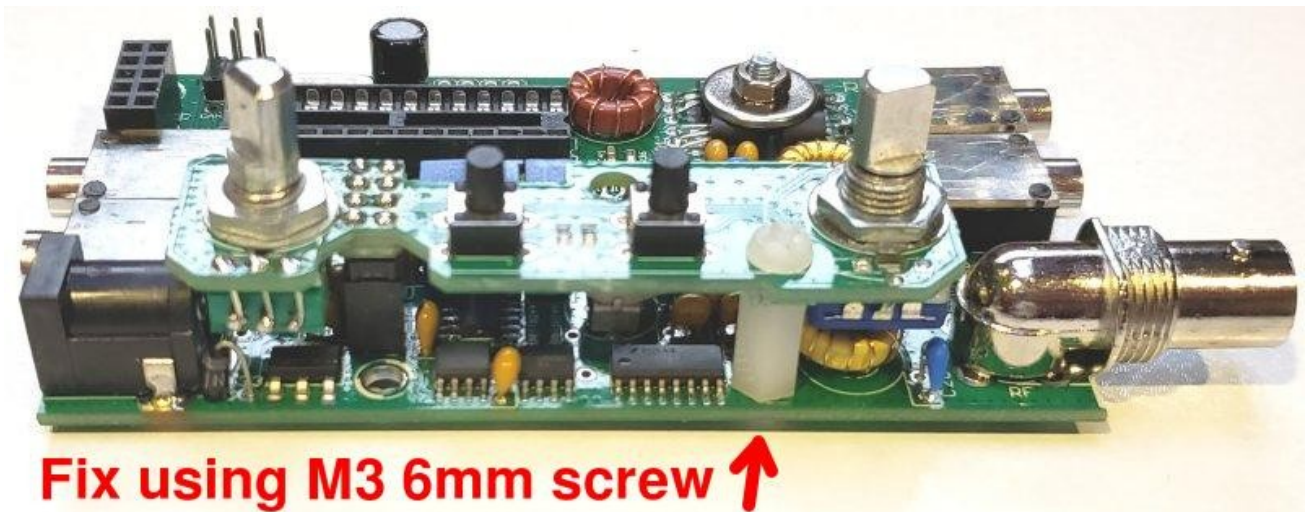

Fix using M3 6mm screw ↑

3.41 Install microcontroller

Install IC2, the programmed ATmega328P microcontroller, in the 28-pin DIP socket on the main QCX-mini PCB.

Be very careful to ensure that the dimple on the chip is aligned with the dimple on the 28-pin DIP socket, which itself should already be aligned with the dimple on the PCB silkscreen.

Note that IC pins are always slightly splayed outward and will not fit into the socket. It is necessary to gently apply pressure on each row of pins on a flat surface such as the workbench, to be able to fit the IC into the socket.



3.42 Plug together the two boards

Now you can carefully plug together the two circuit boards. The best way to do this is to concentrate on getting the 5-pin headers at the top left of the PCBs, to mate accurately with each other. The rest should fall into place by itself.

If you have taken care particularly with filing off the rough edges of the PCBs when the Display board panel was broken out into the sub-PCBs, then you should find that the Controls PCB will fit perfectly (though snugly) through the gap in the Display board, and it will be elevated 1.6mm (one PCB's thickness) above the Display board.

Check that C24 (470uF electrolytic capacitor) isn't blocking the way for the bottom left (as viewed from the front) black metal retaining tab of the LCD body; if it is, you can gently bend the metal tab flatter onto the LCD module PCB to avoid the conflict.

Construction is now complete! Alignment steps must be done BEFORE installation in the optional enclosure.

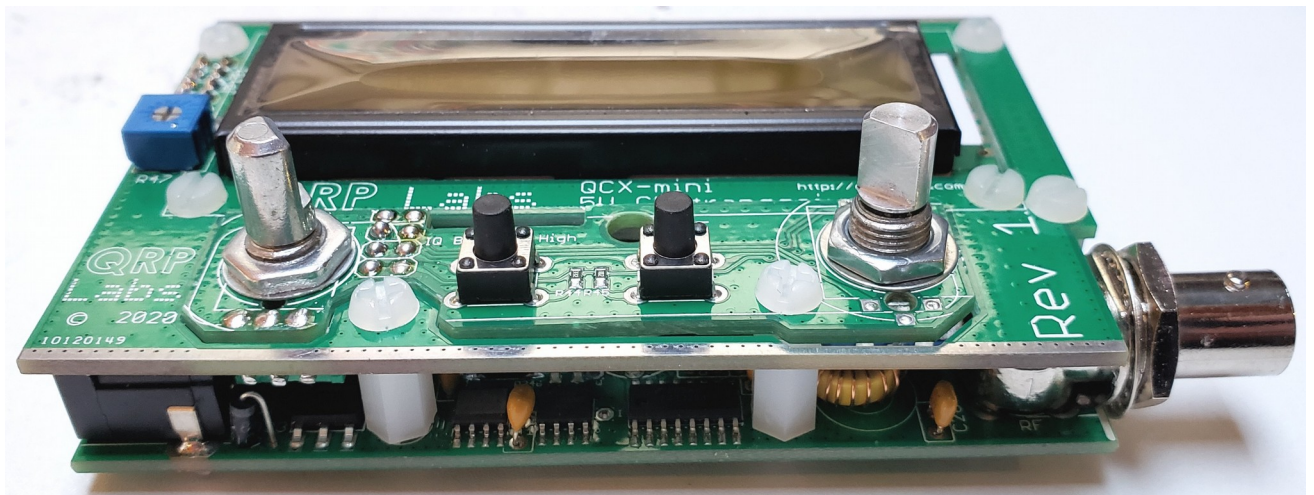

3.43 Connections for basic operation

The following connections are required for basic transceiver operation.

1) Power supply

A power supply is required, which needs to be able to supply up to 0.5A or a bit more, on transmit. The supply voltage may be from 7 to 14V, and the RF power output will depend on the supply voltage (higher output power is produced at higher supply voltages). Operation much above 5W output is not recommended and could lead to overheating and destruction of the final amplifier.

A 2.1mm DC connector plug is required; the center pin is + and the barrel is ground (negative).

2) Earphones

The earphones can be any stereo earphones such as commonly used with audio equipment, mobile phones and so on, with a 3.5mm stereo jack plug. These commonly have a 32-ohm impedance. Some people have noted unstable audio operation when low impedances are connected such as 4 or 8-ohm speakers; this is because the output op-amp IC (IC10) is not able to supply the required power output.

If you want to use a small loudspeaker you will need to ensure this is an “amplified speaker” because the audio output will not be strong enough to drive a speaker directly.

3) Antenna system

The RF output is a filtered 50-ohm BNC output for connection to a usual antenna system (antenna, and matching unit if applicable).

4) Straight key or paddle

To operate the QCX-mini transceiver a straight key or paddle should be connected to the appropriate jack, having a 3.5mm stereo jack plug. The shield (or main body) is ground. It does not really matter which way around the tip and ring connections are (to dit or dah of the paddle) since if they are the wrong way, there is a menu configuration item to swap them around. Similarly if using a straight key, you can select in the firmware either tip, ring or both for the connection; this allows use of a 3.5mm mono plug when using a straight key.

3.44 Notes on fault-finding for the QCX-mini

If your QCX-mini doesn't work at all, or doesn't work properly, don't panic. This is a KIT and as such, often things may not go perfectly as planned and some fault-finding is necessary. The following are some tips to help.

- 1) On first power up, the QCX-mini may look dead, totally dead. No backlight on the LCD module, and no text. This is probably OK! The backlight is controlled by a menu item (in menu 7, the “Other” settings menu) and if that is OFF, then this explains why the backlight is off. Seeing no text on the display is also normal until you have adjusted the LCD contrast potentiometer R47.
- 2) You can remove the Controls board to do certain fault-finding. Since R46 (10K resistor) was thoughtfully placed on the main board, not on the plug-in controls board, this means that if you remove the Controls board, the processor will not register any phantom button presses. The radio will remain in whatever state you put it in, until you plug back in the Controls board. Removing and inserting the Controls board can be done while QCX-mini is switched on.
- 3) If you remove the Controls board however, you are also necessarily interrupting the audio signal path because you have removed R36, the gain control potentiometer. Therefore no audio signal will reach IC10 and there will be no audio output.
- 4) You can remove the Display board and the QCX-mini will continue to work just fine – only you won't be able to see anything on the screen, of course. This can be useful for accessing the main board to check signals at various points. If you plug in the LCD module again while the QCX-mini is powered, you will NOT see any sensible display until you cycle the power, because the display module requires a certain initialization sequence.
- 5) Always connect a 50-ohm dummy load during testing or investigation!
- 6) There is a thorough trouble-shooting guide here:
<http://qrp-labs.com/qcxmini/trouble.html> – it is written originally for the QCX transceiver but the circuit is the same, so it is equally applicable to the QCX-mini.
- 7) There is a trouble-shooting YouTube video see
<http://qrp-labs.com/qcxmini/troublevideo.html>, which explains how to use low cost

test equipment to investigate the signal path of the QCX. Again, this guide was filmed for the QCX transceiver, but since QCX and QCX-mini share the same circuit, it is equally applicable to the QCX-mini.

- 8) **POWER OUTPUT:** Often, the power output is less than you had hoped. If you have power output at all, this is a good indication that the transmitter is working properly. There is a YouTube video about tuning your QCX+ and again, this applies equally to the QCX-mini since the circuit is the same, just a different physical layout. The video explains how to adjust the toroid inductances to achieve at least 4W output with 12V supply (normally closer to 5W) on any band QCX+ 80 to 17m, and at least 5W with 13.8V supply (normally nearer to 6W).
- 9) <https://groups.io/g/qrplabs> is the QRP Labs discussion forum and is full of very helpful people who will be able to advise. Be sure to describe your problem as fully as possible since without this, any faults will be impossible to diagnose.

3.45 Adjustment and alignment

The first thing that you will notice when you apply power to the radio, is that there is probably nothing at all shown on the display. Perhaps the LCD back-light will not even be on (it depends on what configuration is currently saved), and there will be no visible signs of life at all. Don't worry (yet).

This is because you need to adjust the contrast trimmer potentiometer R47 at the top left of the display board! Adjust it with a screwdriver until the display text looks right to you.

You should now see the following text on the display:

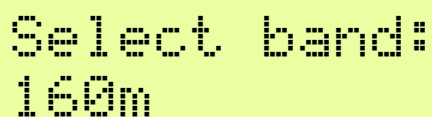

```
Select band:  
160m
```

Turn the rotary encoder knob to select the band you have built the kit for. Then press the left button to make your selection.

If you do NOT see the “Select band” message, but instead the unit appears to be already on a particular band, then please refer to the operation manual and execute a “factory reset” then try again.

There are four more adjustments which now need to be made as part of the alignment procedure. The adjustments are:

- Band-pass trimmer capacitor peaking, C1
- I-Q amplitude balance, R27
- Audio phase shift adjustments, R17 and R24

Until these are adjusted, the sensitivity of the radio will be very low. So, do this first, before going any further!

The location of these four adjustments is very easy to see and use, right above the push-buttons, as shown in the following picture:

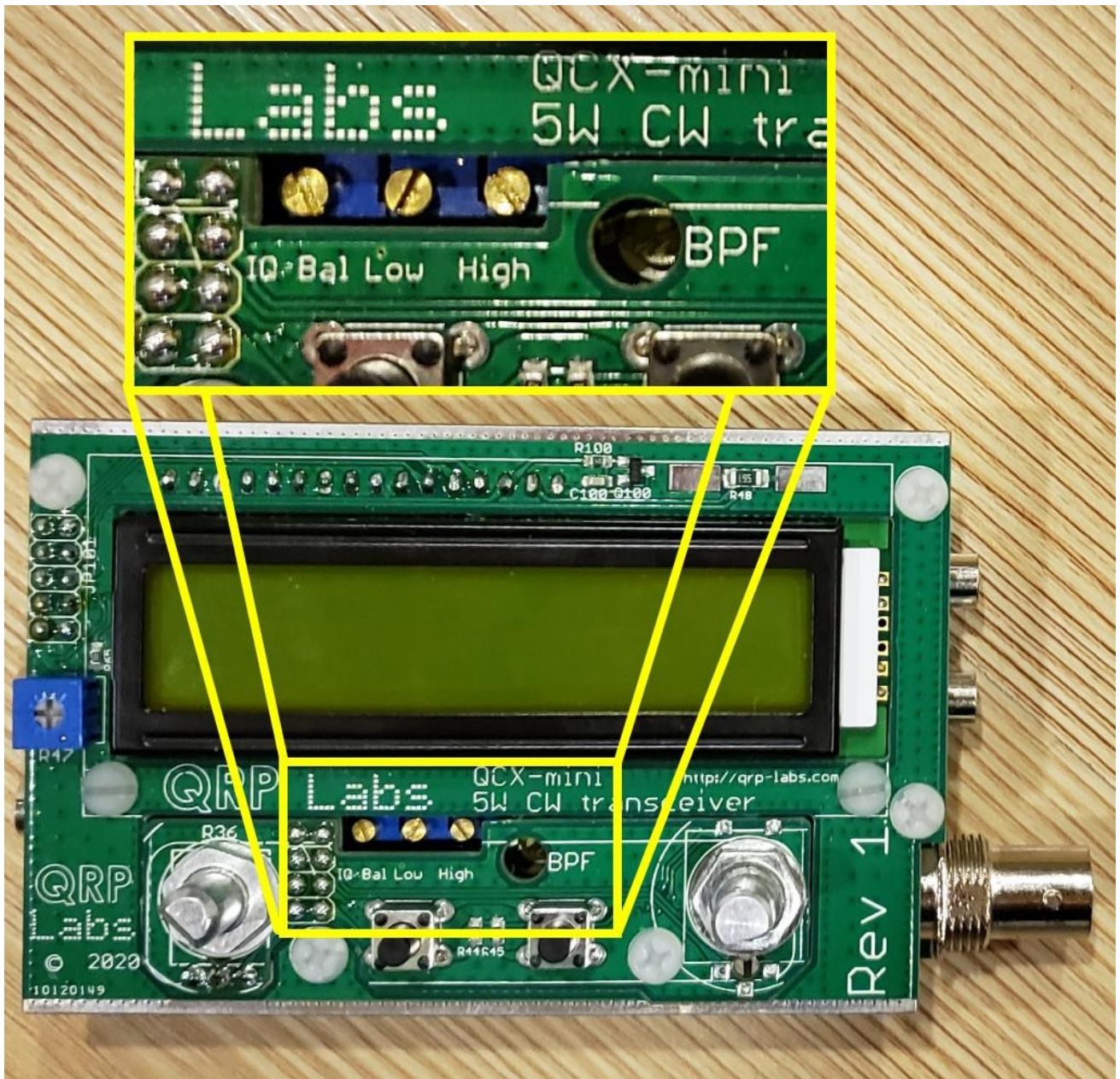

In summary: the alignment tools built into the radio consist of a signal generator which injects a signal into the RF front end, and digital signal processing which adds a 250-Hz digital filter to the existing 200Hz analogue filter, and calculates the amplitude of the signal detected in that bandwidth. During alignment, the amplitude is displayed on-screen as an intuitive bar across the bottom row of the display. Using a screwdriver, you adjust the trimmer component in order to maximize or minimize the displayed amplitude.

Unplug the antenna during alignment of the radio! Connect a 50-ohm dummy load such as the QRP Labs dummy load kit <http://qrp-labs.com/dummy>

When using the TCXO module option, change menu item 8.5 Ref frq to 25,000,000. It is critical to this before any further alignment. Enter the menu system as described below, and turn to menu 8.5, edit it to 25,000,000.

First adjust the band-pass trimmer capacitor C1. To do this, give one long press to the “Select” (left) button. The screen now displays the first menu category:



1 Preset

Turn the rotary encoder until you see the alignment menu:



8 Alignment

Now press the “Select” button, to enter the alignment menu. For example, for 17m operation, the alignment frequency menu item should already be set to a frequency in the CW section of 17m, as follows:



8.1 Align frq
18,120,020

Now turn the rotary encoder until you see:



8.7 Peak BPF
Press Select!

Do as it says! **But if you have earphones plugged in, please take them out of your ears first.** The tone will be very loud. Press the “Select” button to switch on the signal generator so you can adjust the C1 trimmer potentiometer. Now if you have earphones plugged in (and lying hopefully, on your bench), you will hear a loud tone at 700Hz. The display will look like this photograph (QCX/QCX+ i.e. blue display; on the QCX-mini, the display is yellow):



Adjustment of the C1 trimmer capacitor should change the size of the amplitude bar. You need to adjust the C1 trimmer for MAXIMUM amplitude. There will be TWO peaks per rotation, since the capacitor has no stops; either peak is fine. When this is done, the peak of the band pass filter will be centered on the CW section of the band.

It is very important to understand the number at the top right of the LCD, here shown as 09. This is an amplitude scaling factor, expressed as a power of 2. In this example, the actual amplitude is divided by a factor of 512 (2 to the power of 9) then displayed on the screen. In

this photograph, 27 little vertical bars are shown, which means the actual measured amplitude value is 13,824.

If the displayed bar drops below one third of the width of the LCD, then the division factor is reduced by one and the bar is re-displayed. On the other hand, if the displayed bar overflows the right edge of the screen, the division factor is increased by one. This simple method creates an auto-scaling display of the amplitude.

Therefore, to peak the band pass filter trimmer, first adjust the trimmer capacitor while looking at the division factor in the top right of the LCD. Then carry out the fine adjustment using the displayed amplitude bar. The peak is quite sharp.

Be wary because there can be more than one peak (more than one response of this simple band pass filter). So, tune the trimmer capacitor through its whole range, and determine the maximum scaling factor that you see. In my case here, it is 09. You may see 07, 08 etc, no problem. Then make the very fine adjustment necessary to peak the amplitude bar.

When you have peaked the response, check carefully that the C1 trimmer capacitor is not at either end of its range. If it is, this means the resonant circuit is NOT correctly peaked. You need to adjust the number of turns on the long secondary winding of the T1 transformer. Visual inspection will show clearly whether or not the trimmer capacitor is at the end of its range.



Perfect!

OK! The “solder blob” on the top plate is somewhere between the 4 o'clock and 8 o'clock position. The plates of the trimmer capacitor are somewhere nicely in their range, not at the minimum or maximum capacitance. You have found the peak response of the BPF and all is well.



Plates completely closed

Here the fixed and movable sets of capacitor plates are completely meshed, resulting in the highest capacitance. The “blob” is to the right. It means MORE inductance is needed. So carefully unsolder one end of the secondary 3 winding of T1, join a piece of wire, and wind it 5 more turns through the toroid. Then try again. Don't worry if it looks a bit messy.

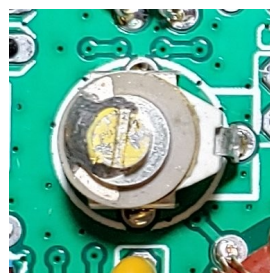

Plates completely open

Here the fixed and movable sets of capacitor plates are completely unmeshed, resulting in the lowest capacitance. The “blob” is to the left at the 9 o'clock position. It means LESS inductance is needed. So carefully unsolder one end of the secondary 3 winding of T1, remove 5 more turns through the toroid, and resolder. Then try again.

Adjustment of I-Q balance

Now turn the rotary encoder “one click” clockwise to measure I-Q balance.

Note that the previous alignment used the audio signal BEFORE the final amplification stage, so the gain control had no effect on the signal level. In contrast, the I-Q balance and audio phase shift adjustments use the audio signal AFTER the audio amplification stage. This is necessary because these alignment adjustments inject a signal into the opposite (unwanted) sideband, and the signal level is much lower, therefore it needs to be amplified for the microcontroller to be able to measure it accurately. In this case therefore, the gain control DOES now have an effect. I suggest adjusting the gain control approximately to mid-way to start with. This will provide enough gain, yet not so much gain that the amplifiers are driven into overload, which distorts the signal and measurements.

You should try to carry out the adjustments with the measured audio values in the range 5 to 10 (as indicated by the division ratio in the top right of the display). If it reaches 12, the operational amplifiers are limiting, clipping the signal which will make it difficult or impossible to make the adjustment accurately. If the displayed value (top right of the display) is only 2 or 3, that indicates the gain is too low. Therefore, adjust the volume control so that the display is something like 9.

The I-Q trimmer potentiometer is R27. It is a multi-turn trimmer potentiometer so it may need to be turned quite a few times to get to the optimum value! For this adjustment, you are looking for the MINIMUM amplitude, not the maximum we adjusted the BPF trimmer to. We adjust for minimum because now the injected signal is measuring the unwanted sideband. We want to MINIMIZE the unwanted sideband level.

Adjustment of 90-degrees audio phase shift

Similarly turn the rotary encoder one more “click” clockwise, which automatically sets the unwanted sideband audio signal to appear at 600Hz, and adjust the “low audio phase shift” trimmer potentiometer, R24. Again, adjust it for MINIMUM signal.

Turn the rotary encoder clockwise one more “click” and adjust the “high audio phase shift” trimmer potentiometer R17, again for minimum signal.

Now it is necessary to go back and forth between these three menu items for minimum unwanted sideband:

- 8.8 I-Q Bal (adjust R27)
- 8.9 Phase Lo (adjust R24)
- 8.10 Phase Hi (adjust R17)

This is because to some extent, these adjustments influence each other. Obtaining the optimum set of adjustments is an iterative process. So, turn the rotary encoder a click at a time anti-clockwise or clockwise, back and forth through these three menu items. Each time make small further adjustments to the appropriate trimmer potentiometer and observe the lower amplitude. Keep doing this until you see that you cannot really manage to get the unwanted sideband any lower in any of those adjustments. Pressing the “Exit” button twice leaves the menu system and returns the radio to normal operation.

Other items in the alignment menu relate to the calibration of the 27MHz reference oscillator of the synthesizer, and the 20MHz system clock oscillator of the microcontroller. These adjustments can be made manually, or by connection of a GPS module such as the QRP Labs QLG1 GPS receiver kit. However, since this calibration is a lot less urgent than

the Band Pass Filter peaking and unwanted sideband cancellation, they are left until the description of these menu items in the operating manual.

Following the adjustment of these alignment trimmers, the radio is ready to use. A lot of settings are available in the configuration menu, and you should read the operation manual to understand and make use of all the features!

You may now bolt the two PCBs together by screwing the four M3 6mm nylon screws into the 11mm spacers which hold the two PCBs at the correct separation; and you may fit the knobs to the two rotary controls. However, if you are going to install the QCX-mini in its optional enclosure, please follow the steps in the following section.

3.46 Installation in the optional QCX-mini enclosure

Installation in the QCX-mini enclosure is simple and requires no wiring. It is important to do the assembly in the correct sequence, as follows.

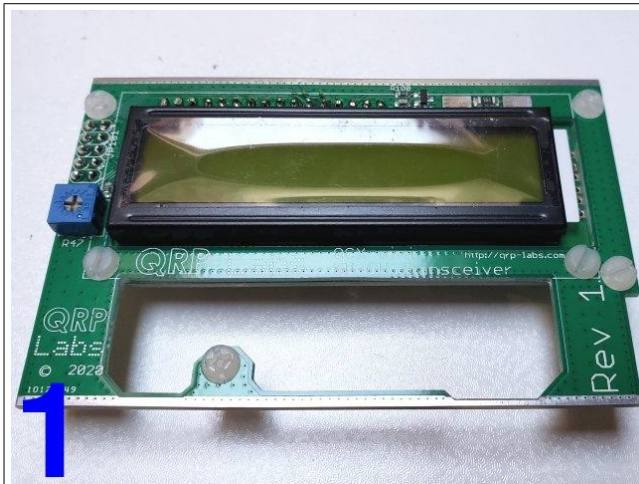

1 Start with the Display board...

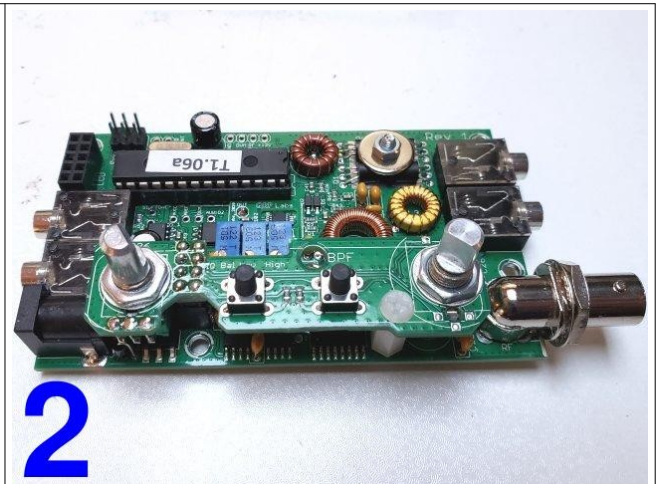

2 ... and the main board, with the controls board bolted in position.



3 Peel off the plastic protective coating from the LCD module.

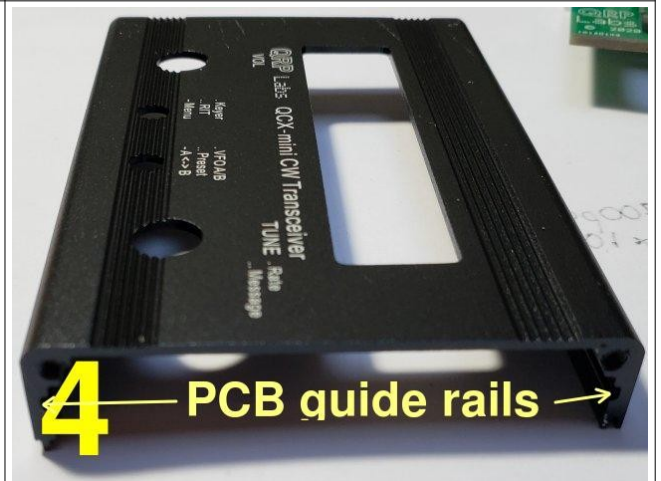

4 Here's the top half of the enclosure. Note the PCB guide rails in the extrusion walls.

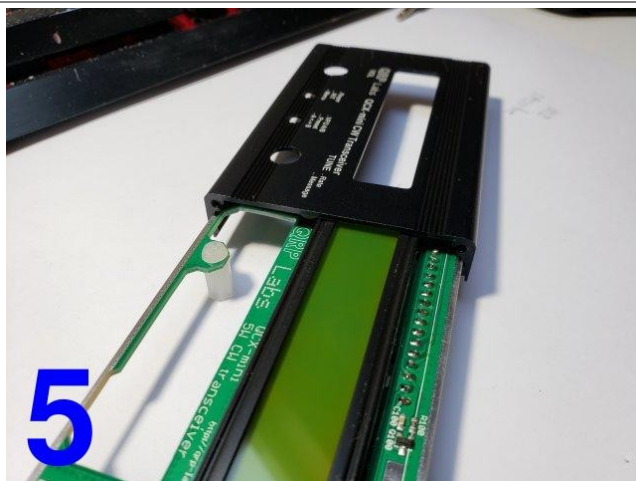

5 Slide the display board into position along the PCB guide rails in the enclosure.



6 Bolt the right-hand side panel to the main PCB using the supplied BNC washer and nut

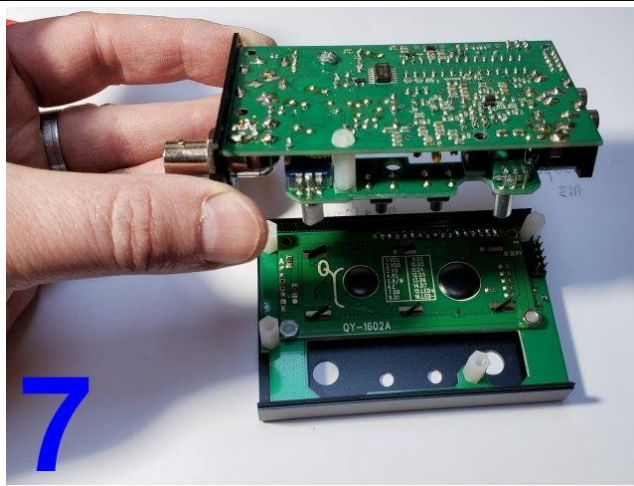

7
Place the front of the enclosure face down on the bench as shown, and prepare to attach the main board.



8
Align the 2x5-pin header connector between the main and display boards; some wiggling will be needed to get the controls to fit through the holes in the front panel.

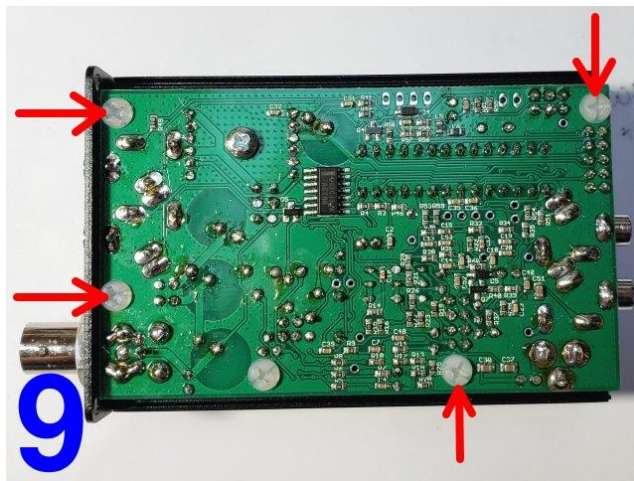

9
Fit four M3 6mm nylon screws in the positions shown



10
This is how it looks from the DC connector end

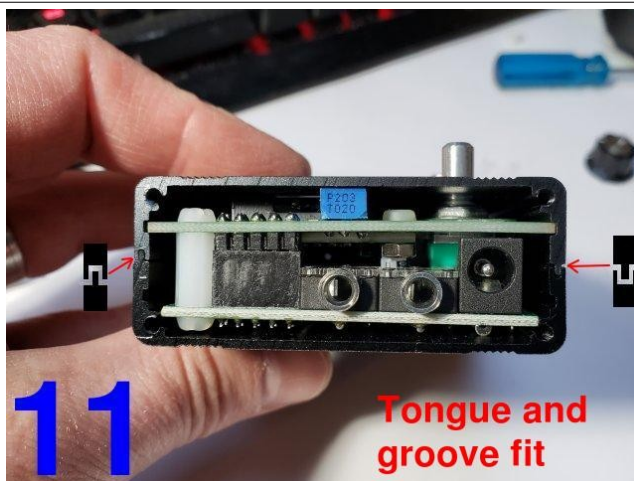

11
Tongue and groove fit
Determine correct orientation of the bottom half of the enclosure; note the tongue-and-groove arrangement which means that the bottom half only fits one way round! Make sure you have the correct way.



12
Now bolt the left-hand side panel to the enclosure extruded top and bottom halves using four of the supplied small black countersunk screws in the panel corners. The screws need to be carefully aligned and should screw in easily (if properly aligned).



13
Screw in the other four black screws in the corners of the right-hand side panel.



14
Apply the supplied four self-adhesive feet to suitable positions on the base of the enclosure if desired (optional).

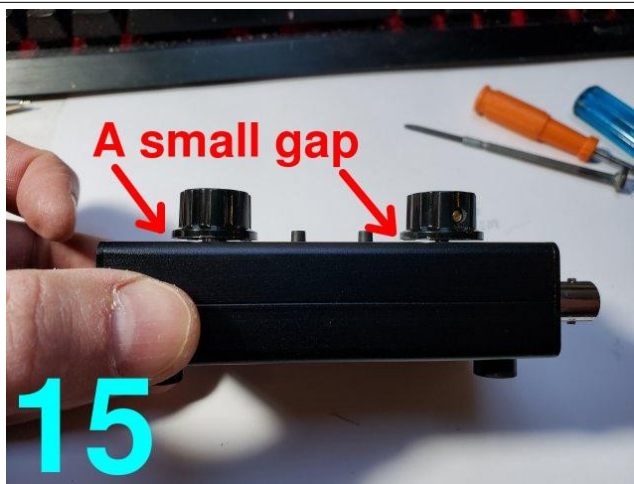

15
Install the supplied knobs by tightening their grub screws. Leave a small gap between each knob and the front panel, to allow the knob to turn easily. The grub screw of the volume control knob should be at the position of the flat on the shaft. The grub screw position on the rotary encoder is not important.



16
Plug in the power...
SUCCESS!
(hopefully)

Disassembly of the QCX-mini should follow similar steps, in reverse.

3.47 QCX-mini GPS interface and PTT output

The picture below shows the connectors on the main QCX-mini PCB.



GPS interface

The QCX-mini has a GPS interface which can be used to:

- Calibrate the reference oscillator (27MHz crystal or 25MHz TCXO module option) and the 20MHz system oscillator
- Keep the oscillators disciplined and drift-free (frequency and time) during WSPR beacon operation
- Set the internal Real Time Clock, which is critical for WSPR options and may be displayed on-screen if you have configured it.

The GPS produces two output signals, PPS (Pulse-per-second) and RxD (Serial data), in addition to ground. Optionally +5V may also be connected, in order to power the GPS module. A GPS such as the QRP Labs QLG1 is perfect for this see <http://qrp-labs.com/qlg1>

The GPS signals (PPS and RxD) use the same microcontroller pins as the paddle Dah and Dit respectively. Therefore you cannot use the Paddle and GPS at the same time. In fact, you should only connect the GPS during the calibration of the synthesizer reference frequency, system clock, and while operating the QCX-mini as a beacon (CW, FSKCW or WSPR).

The following diagram shows the connections.

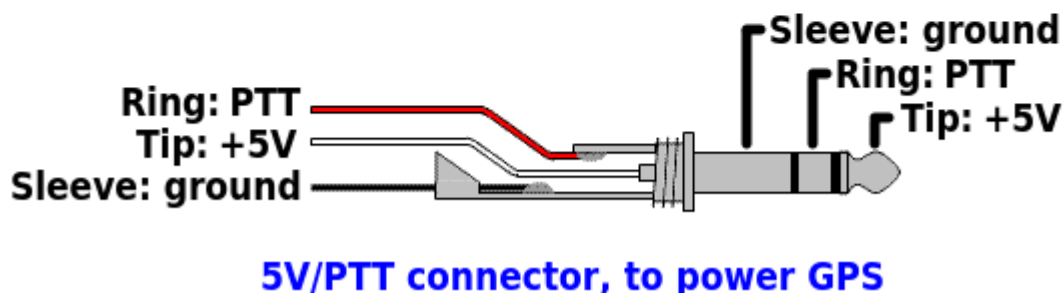
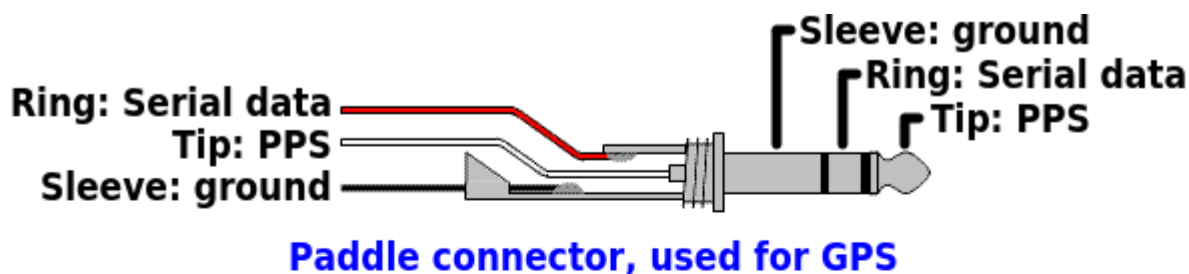

PTT output

The PTT output is at the ring of the 5V/PTT connector jack. This signal is 0V when the QCX-mini is in Receive mode, and +5V when the QCX-mini is in Transmit mode. If you are connecting the QCX-mini to the companion 50W PA kit, then this signal has to be connected to the 50W PA kit to cause it to switch to Transmit mode. A standard 3.5mm stereo audio cable can be used (having a 3.5mm stereo jack plug on each end).

Note that the pinout of the 5V/PTT connector is not the same as the Rev1/2 QCX+ PCBs. In the QCX+, ring is +5V and tip is PTT. This has the disadvantage that plugging in a cable while the QCX+ is powered, can short the +5V to ground. Another disadvantage is that standard 3.5mm stereo audio cables can't be used. For this reason, complete compatibility was broken in this instance. If you wish to use a 50W PA kit with either QCX+ or QCX-mini, the QCX+ manual contains details of the very simple modification needed to swap the tip and ring connections in the QCX+.

3.48 QCX-mini CAT port

The QCX-mini CAT port allows a PC or other CAT-enabled host to control every aspect of the QCX-mini. Operation of this feature is detailed in the operating manual. The connection diagram below shows the connections to the 3.5mm stereo jack socket connector on the rear panel of the QCX-mini.

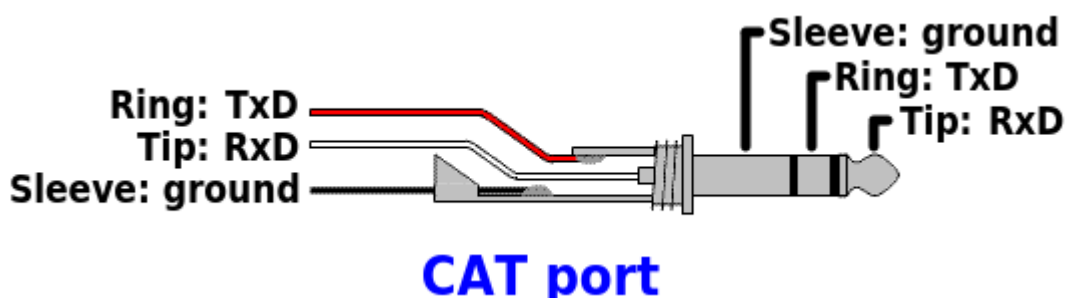

4. Circuit design of the QCX-mini

4.1 Block diagram and summary

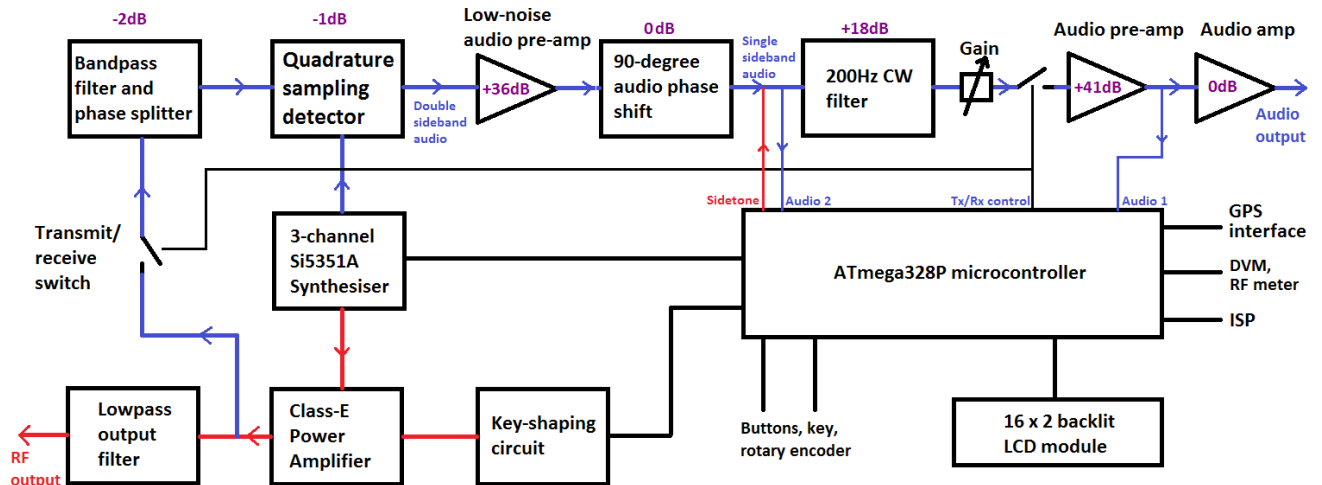

This CW transceiver is a high performance, yet simple and low cost, analogue design. The transmitter uses a high efficiency Class-E amplifier which results in low current draw on transmit, and inexpensive transistors with little or no heatsinks.

The receiver is a direct conversion type utilizing the famous high performance Quadrature Sampling Detector, also known sometimes as the “Tayloe Detector” or even “I-Q Mixer”. This receiver front end architecture has been used in the early Flex Software Defined Radios, Softrock series, Norcal NC2030 and many other SDR’s and other high performance front ends. The detector has very high third order intercept (IP3) and dynamic range, as well as low loss.

The resulting I & Q outputs are at audio baseband and go through a 90-degree phase shift network which cancels the unwanted sideband. A 200Hz bandwidth CW filter is followed by more amplification and drives common earphones.

The oscillators in the transceiver are provided by the modern Si5351A digital phase locked loop IC controlled by the microcontroller.

Permeating the entire design is microprocessor control by the ATmega328P microcontroller. This allows implementation of a large number of functions normally only found in radios costing 10-100x the price!

A really nice feature of the design is the built-in alignment and test equipment, which make it possible to build, align and even debug the assembly of the radio, all with NO additional test equipment.

4.2 Circuit diagram

A bit small to read – but a larger resolution version is available on the web page <http://qrp-labs.com/qcxmini>, and anyway the explanation will be in smaller circuit blocks.

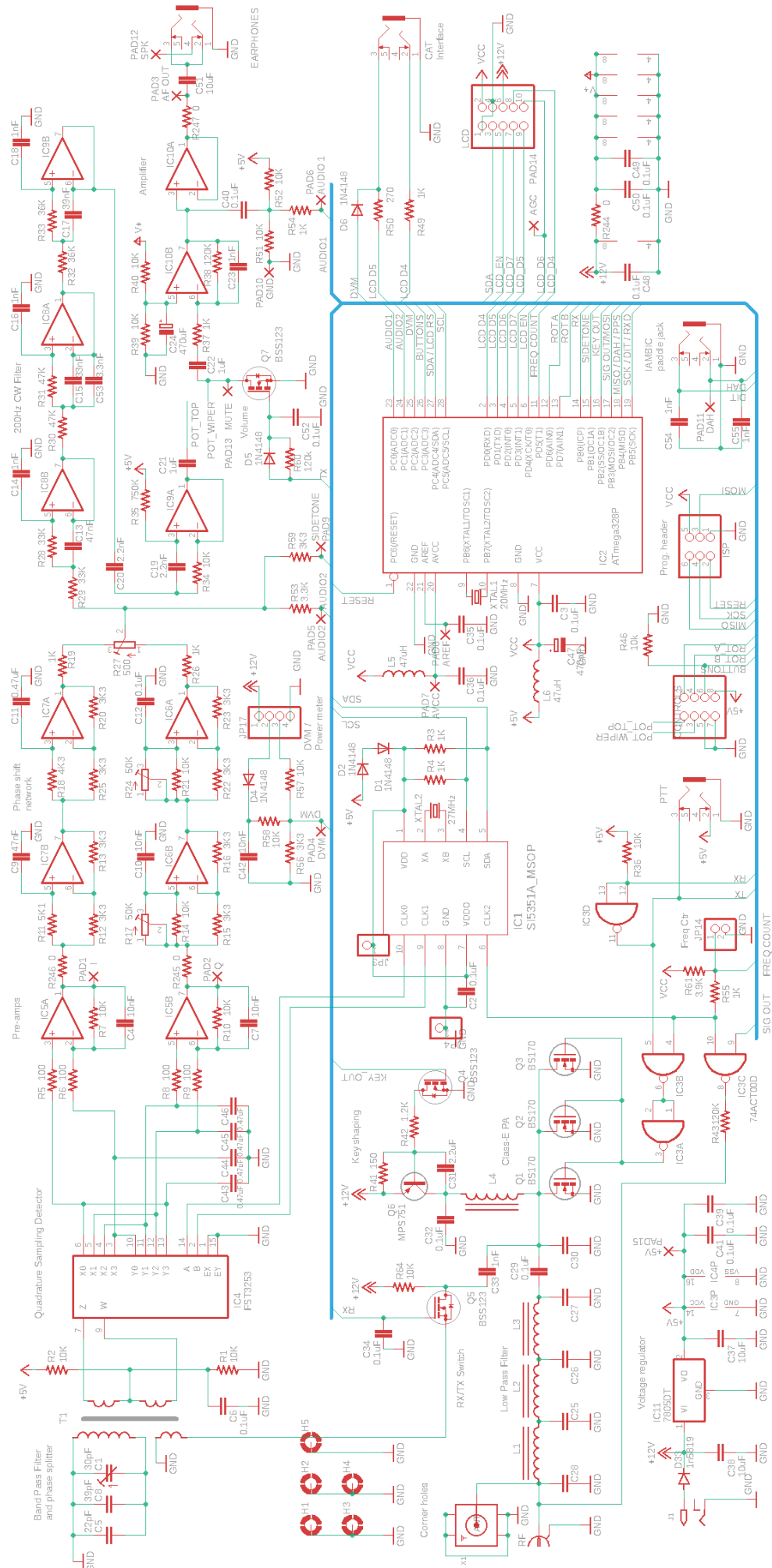

The circuit diagram (schematic) of the main PCB is shown on the previous page. The circuit diagram of the display PCB is shown below.

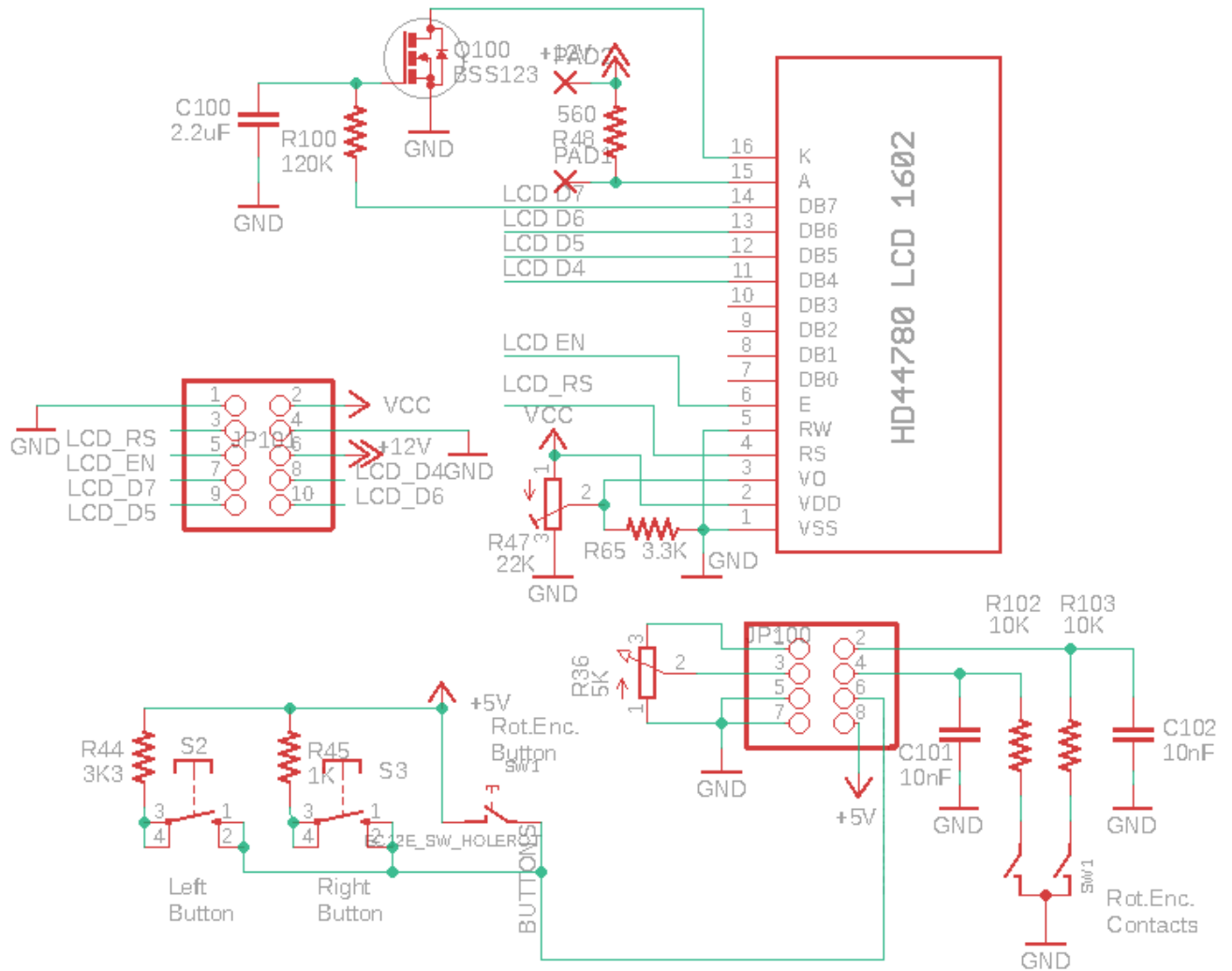

The circuit diagram of the uSDX daughterboard is shown below. Refer to the uSDX groups.io forum <https://groups.io/g/ucx> for details of this modification.

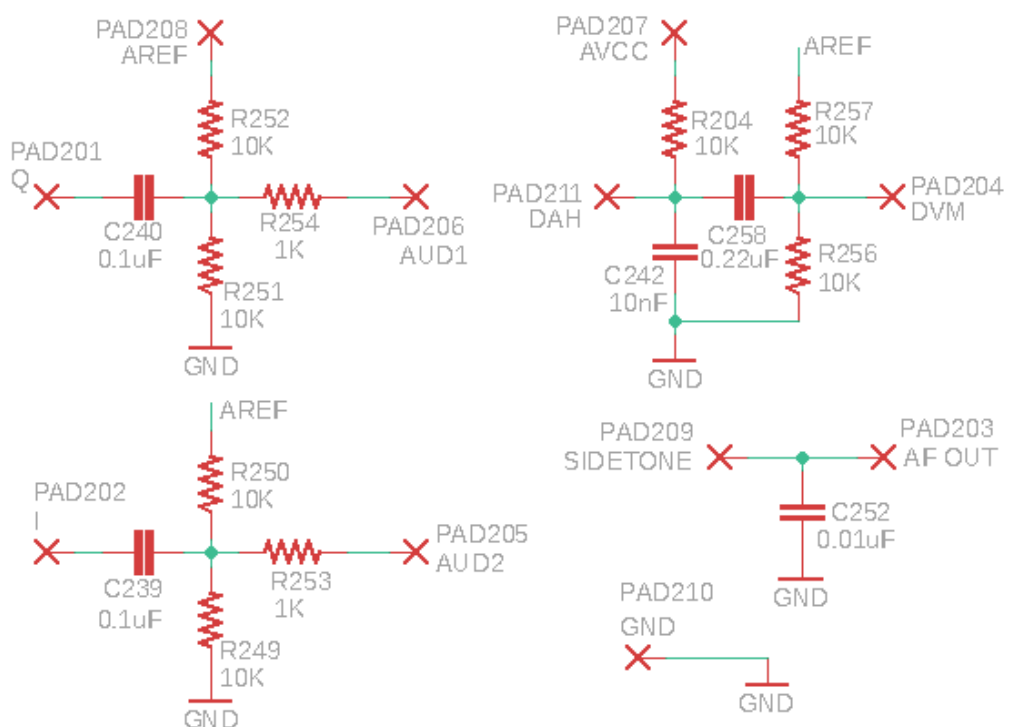

4.3 Synthesized oscillator

I always start with building the VFO of a radio. It was the hardest thing to get right. How to get that analogue LC-tuned VFO accurate, free of drift, free of chirp, tuning over the required range, and with mechanical gearing to be able to make fine frequency adjustments? A real challenge. Not anymore! Now we have Direct Digital Synthesis (DDS) ICs and Digital Phase Locked Loop (PLL) ICs, inexpensive and easy to use, that solve all the problems.

The Si5351A Synthesizer chip used in this design provides three separate frequency outputs, with a frequency range spanning 3.5kHz to 200MHz. The frequency stability is governed by the 27MHz crystal reference. Pretty stable, in other words.

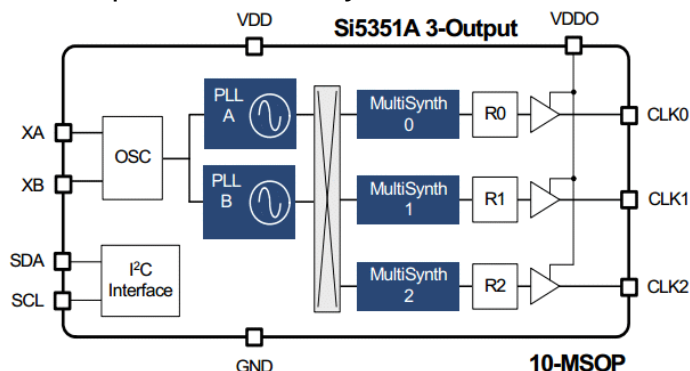

The block diagram (right) is taken from the SiLabs Si5351A datasheet. Briefly, the 27MHz reference oscillator is multiplied up to an internal Voltage Controlled Oscillator in the range 600-900MHz (the PLL), then divided down to produce the final output frequency. The multiplication up and the division down are both fractional and so the frequency resolution is extremely finely controlled. The chip has two PLLs and three output divider units.

For best jitter performance, the Si5351A datasheet recommends the use of even integer dividers (no fractional component) in the MultiSynth dividers and in this CW transceiver design, this recommendation is followed.

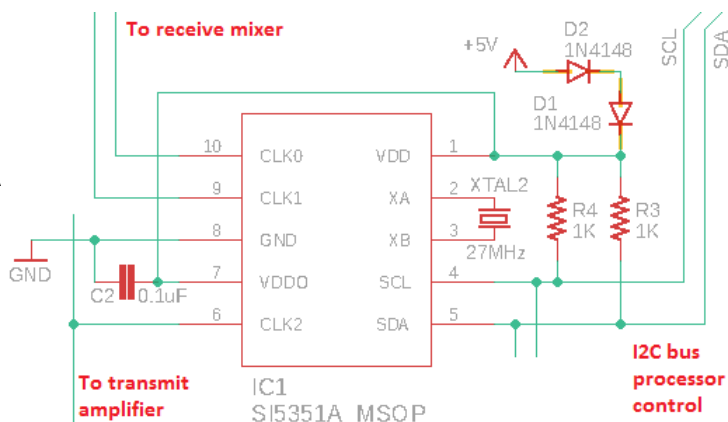

The synthesizer section of the circuit diagram is shown here (right). The Si5351A datasheet dictates the use of a 25 or 27MHz crystal. QRP Labs has always used the 27MHz crystal in our designs because it allowed us to obtain precise 1.46Hz tone spacing for WSPR transmissions all the way up to the 2m amateur band (145MHz). Those calculations don't work out with the 25MHz crystal. This requirement doesn't apply to this CW transceiver design but economies of scale means there are advantages to sticking with the same component values, all other things being equal!

The Si5351A has a large number of internal 8-bit registers to control the synthesizer behaviour, and these are programmed by the microcontroller using the I2C serial protocol. 1K resistors R3 and R4 are pull-ups required for the operation of the bus at 400kHz.

The Si5351A chip requires a 3.0 to 3.6V supply (nominally 3.3V) but the rest of this transceiver's digital circuits operate with a 5V supply. For the reduction of complexity and costs, two 1N4148 diodes in series are used here to drop the 5V to a suitable voltage for the Si5351A. It works well.

There are three outputs of the Si5351A synthesizer and these are all used to good advantage. The Clk2 output is used to feed the transmit power amplifier, and the Clk0/1 outputs are used to drive the Quadrature Sampling Detector (QSD) during receive. These

outputs can be switched on and off under the command of the microcontroller. This provides an opportunity for some simplification because the Clk0/1 outputs can be simply switched off entirely during transmit. This relieves pressure on the transmit/receive switch. There just cannot be any reception during transmit because there is no oscillator input to the receive mixer. Conversely, the Clk2 output is switched off during receive.

A feature of the Quadrature Sampling Detector is that either the RF input, or the LO input, must provide two paths in 90-degree quadrature. This is normally applied at the Local Oscillator where it can be easily controlled for best performance. So, two oscillator signals are required, with the same frequencies but a precise 90-degree phase offset. Generating this quadrature Local Oscillator signal is always difficult. Analogue phase shift circuits have limited accuracy. Often a divide-by-4 circuit is used, to produce quadrature oscillator outputs from an oscillator input at 4x the reception frequency. This also creates challenges particularly as you try to increase the reception frequency to cover higher bands. For example, on 10m e.g. 30MHz, a local oscillator at 120MHz is required and the divide-by-4 circuit must be able to operate at such a high frequency. Devices such as the 74AC74 can do so, but pushing it higher into the 6m band cannot be done with the 74AC74.

The Si5351A has a phase offset feature, which is not really very clearly described in the SiLabs documentation. However, QRP Labs has perfected the technique to put two of the Si5351A outputs into precise 90-degree quadrature, which is maintained without tuning glitches as the frequency is altered. It's a nice development because it eliminates one more circuit block (the 74AC74 divide-by-4 circuit), again reducing complexity and cost. To the best of my knowledge this is the first time the Si5351A has been implemented in a product directly driving a QSD with two outputs in quadrature (no divide-by-4 circuit).

4.4 Transmit/Receive switch

Since the receiver is entirely disabled during transmit, because of the absence of any local oscillator signals to the Quadrature Sampling Detector, the demands on the transmit/receive switch are considerably reduced. Now the circuit does not have to provide the massive amount of attenuation necessary to prevent the transmitter from overloading the receive circuits. All it has to do is provide a reasonable amount of attenuation, enough to stop the 5W signal (45V peak-peak) from damaging the receiver input mixer.

The transmit/receive switch is implemented by a single BSS123 MOSFET. The source is at DC ground (via the primary of input transformer T1). The control signal from the microcontroller switches the MOSFET on or off. Interestingly, capacitor C34 close to the MOSFET gate is found to be necessary to prevent inductive pickup of the 5W RF from partially switching on the MOSFET.

The switch wouldn't provide enough attenuation to mute an operating receiver; but during transmit, our receiver isn't operating; all the switch has to do is protect the Quadrature Sampling Detector from seeing 45V peak-peak which would destroy it.

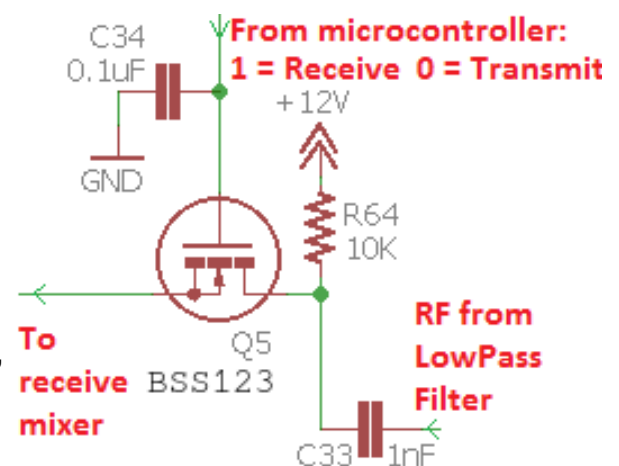

4.5 Band Pass, Phase Splitter, QSD and pre-amps

Since the band-pass filter, Phase splitter, Quadrature Sampling Detector and pre-amp circuits are so tied up together, I am going to consider them all together in this section.

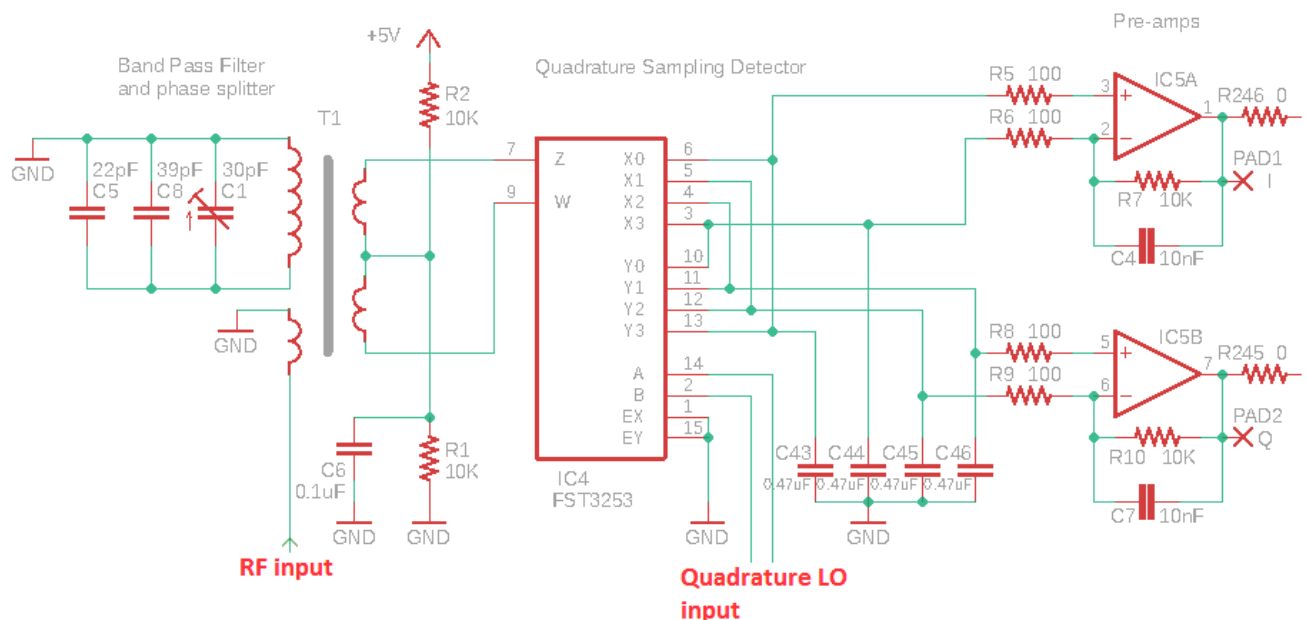

This circuit implements an input band-pass filter and double-balanced Quadrature Sampling Detector with low-noise pre-amps. Yet it does this with a low parts count, and resulting low complexity and cost. The FST3253 is a dual 1:4 multiplexer which is often seen in QSD circuits. It has fast switching times and very low on resistance of only a few ohms. The input signal is switched by the quadrature LO to each of the four integrating capacitors C43-C46 in turn, for 90-degrees of the RF cycle each. The result is that the audio difference (beat) between the RF input and LO input appears across each of the four integrating capacitors, with four phases at 0, 90, 180 and 270 degrees.

The operational amplifier IC5a takes the difference of the 0 and 180-degree outputs and amplifies it, resulting in the I output of the QSD. Similarly, IC5b differences the 90 and 270-degree outputs to produce the Q output.

The combination of the relatively large 470nF capacitors and the low source resistance results in a fast roll-off of the audio response. This is effectively a very narrow band pass filter since any incoming RF more than a few kHz away from the LO frequency is greatly attenuated. The QSD is therefore inherently a very high performance mixer design with high third order intercept and dynamic range, and low loss (0.9dB).

The FST3253 dual switch is often connected with the two switches simply paralleled together (which does half the switch ON resistance). But I prefer the double-balanced mixer configuration which provides higher performance. The double-balanced configuration requires two RF inputs 180-degrees out of phase (opposite to each other).

Despite the high IP3 and dynamic range, it is still prudent to provide some input band pass filtering to protect the mixer from strong out of band signals. In this CW transceiver design, the T1 transformer provides a simple solution to all of these problems with a very low parts count.

The primary couples the incoming RF into the two secondary windings which feed the double-balanced detector. One end of the primary is grounded which neatly keeps the DC potential of the input at ground, so the transmit/receive switch is easily implemented by a

single MOSFET (see previous section). The two secondaries are connected as a center-tapped single winding, which means that the outputs have 180-degree phase difference as required.

The secondary “center-tap” is connected to a DC bias formed by R1, R2 and C6 at mid-rail i.e. 2.5V. This simple bias does not source or sink any significant current due to the balanced nature of the system, therefore no buffering is required. The DC bias feeds through the pre-amps, and into later stages – including the 90-degree phase shift network and the first three op-amps of the CW filter. It is a great benefit not to have to AC couple each stage with coupling capacitors, and then bias each stage individually. In this circuit, the same DC bias flows through all the way from this center-tapped input transformer. This reduces component count and - you guessed it – complexity and cost. Another benefit is that since much of the receiver signal path is DC coupled, it might be easier to reduce the inevitable “thumps” on switching between receive and transmit.

Finally, the band pass filter is implemented by a fourth winding on the same transformer T1, with some fixed capacitors and a trimmer capacitor forming the resonant circuit. It is only a single resonant circuit band pass filter so has limited stop-band attenuation, but it does have the benefit of low parts count, and simplicity of adjustment due to the single adjustment control.

Note that the I and Q outputs each have a 0-ohm resistor (R246 and R245 respectively); removal of these resistors disconnects the I & Q signals from the rest of the audio processing; separate I & Q pads allow the signal to be routed to the uSDX daughtercard if required.

4.6 90-degree audio phase shift

By this stage the I and Q outputs are each double-sideband, and we need to process them to demodulate single sideband.

The circuit used here is an active two-path all-pass phase shift network based on four operational amplifiers. The circuit is based on the same phase shift block as the Norcal NC2030 <http://www.norcalqrp.org/nc2030.htm>

In the real world, nothing is perfect – there are component tolerances to think about. The unwanted sideband suppression is maximized when the amplitude of the two paths are equal, and the 90-degree phase shift is accurate.

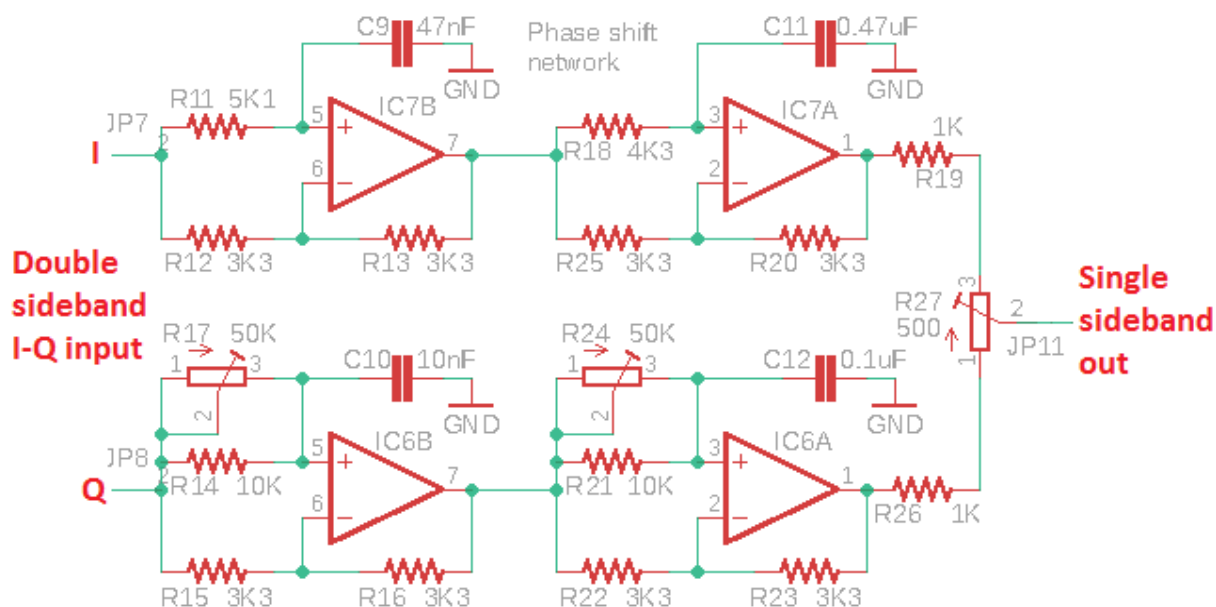

To improve the accuracy of the 90-degree phase shift, R17 and R24 allow adjustment of the phase shift at higher and lower audio frequencies respectively.

R27 allows adjustment of the balance between the I and Q channels, to equalize the amplitude from each path.

This CW transceiver kit includes built in alignment and test equipment, with a signal generator that can inject a test signal into the receiver input. It makes it easy to perform these adjustments, as described previously.

Note the 2-pin header pads JP9, JP10 and JP11 at the output combination potentiometer which allow experimental modifications or connections.

4.7 CW filter

The CW filter used in this receiver has a 200Hz bandwidth. The circuit is based on the HI-PER-MITE CW filter kit design by David Cripe NM0S, available from the Four State QRP group: <http://www.4sqr.com/HiPerMite.php> (thanks David for permission to use it here). This is a high performance circuit specifically designed to avoid objectionable ringing.

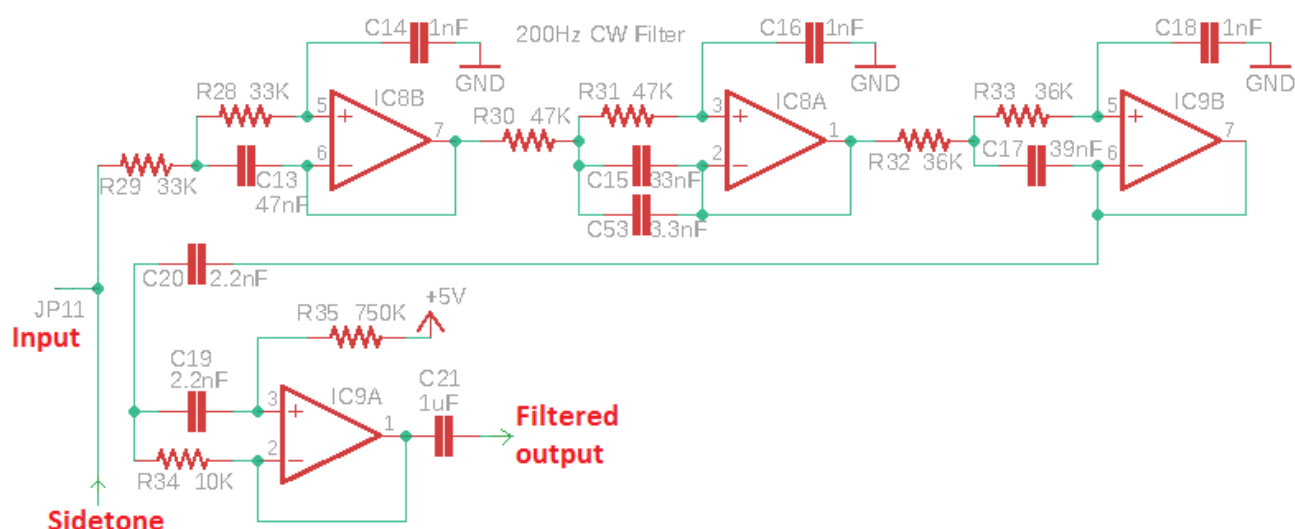

There are three stages of low-pass filtering and one stage of high-pass filtering. The first three stages retain the 2.5V “midrail” bias all the way through from the input transformer T1. The final stage IC9A is biased using the 5V supply (avoiding a few extra components to create a real 6V mid-rail at half the supply).

The CW filter also provides a measured 18dB of gain.

Sidetone is injected at the input to the CW filter, so as to make is sound nice and clean by cutting off the squarewave harmonics leaving a clean 700Hz sidetone.

4.8 Audio amplifier

The final stage in the receiver signal path is the audio amplifier, to drive earphones at a comfortable listening level.

There is a 5K potentiometer on the controls board, used as the gain control. With the wiper fully clockwise the receiver is at full volume. As the potentiometer is turned anticlockwise it forms a potential divider which attenuates the audio signal from the CW filter output. This potentiometer is located on the controls PCB and is not shown on this diagram section (below).

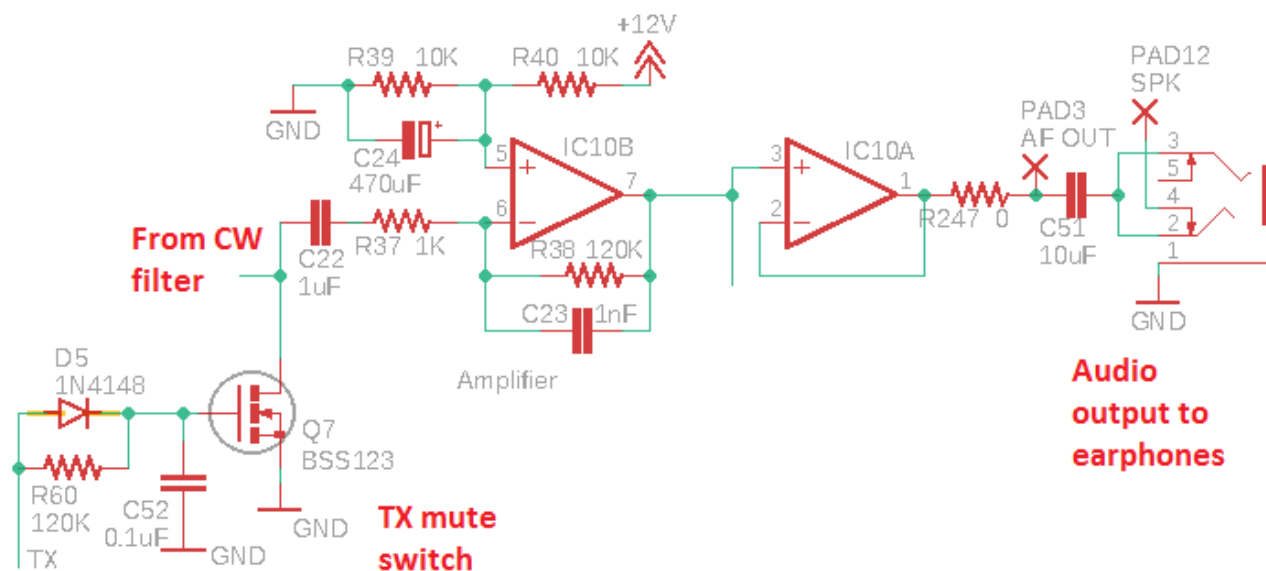

There is also a TX mute switch formed by Q7, another BSS123 MOSFET. This was a late addition to the design: despite all attempts, I could not remove the nasty click on receive/transmit switching. The mute switch helps to attenuate it. The switch is operated by the microcontroller Receive/Transmit switch output. When the BSS123 switch is on, it has a low resistance to ground which greatly attenuates the audio signal.

To reduce the audio “thump” when the transceiver is switched from transmit back into receive, the mute switch needs to remain switched on for a short while after the receiver is switched back on. A small wait while the thump subsides. This delay is achieved by the R-C network formed by R60 and C52. This would also introduce a delayed switch-on of the mute switch, which would allow the thump when switching to transmit to be heard. To prevent this, diode D5 was added, which bypasses the resistor R60 at the receive-to-transmit switchover. It ensures that at the receive-to-transmit event, the mute switch is enabled instantly; but on the transmit-to-receive switchover there is a short delay.

C21 and C22 were originally 10uF electrolytic capacitors in the early QCX PCB revisions. Some constructors experimented and found that if these capacitors are reduced to 0.1uF the residual Transmit/Receive switchover click is even further attenuated. However, 0.1uF also reduces the gain of the receiver chain by 14dB; although overall the receiver has quite high gain, a loss of 14dB may still be too much particularly on higher frequency bands where the noise levels are lower. Therefore, the current kit is supplied with 1uF capacitors, which provide the click attenuation but have negligible effect on the gain.

IC10B is a simple amplifier configured for 41dB of gain. The ½-V mid-rail bias is created by R39, R40 and C24. Using the 5V power line as “mid-rail” was found to add too much noise. Finally, IC10A is a simple unity-gain buffer. Although it is just an op-amp it is found to be perfectly adequate for driving standard earphones.

The effect of the 5K LINEAR (not Log) volume control and the 1K load resistance of the IC10b input is to create an overall logarithmic characteristic. If you would like a more

4.9 Transmit signal routing and PA driver

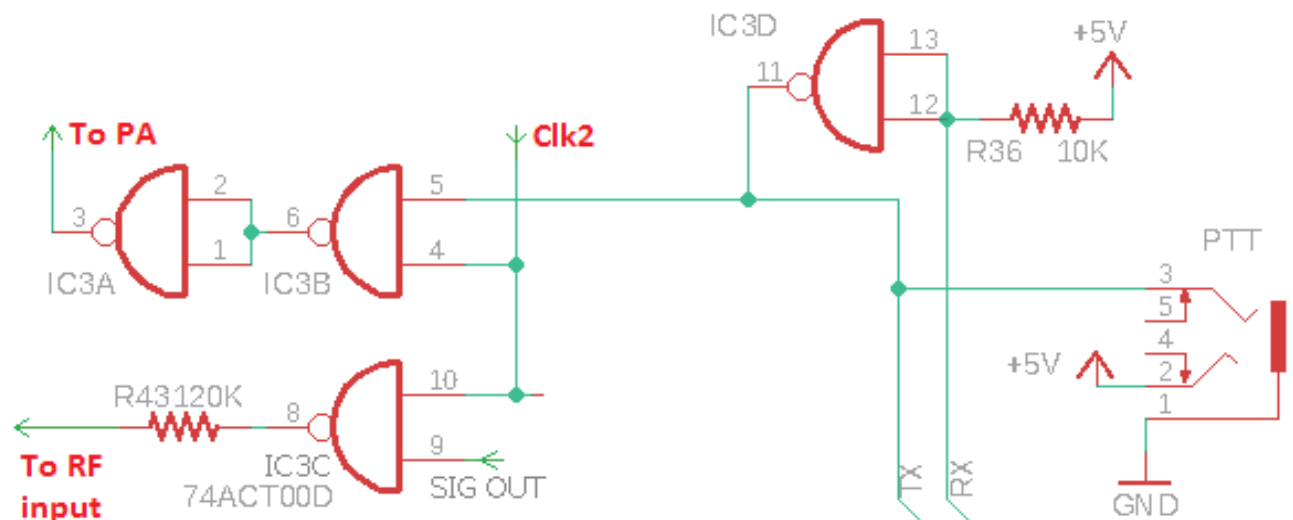

The 74ACT00 is a quad NAND logic gate. The input threshold voltage for a binary “1” is 2.4V which means that the gate is easily switched on by the ~3.3V peak-peak squarewave output from the Si5351A. The output of the 74ACT00 is 5V peak-peak, perfect for driving the BS170 MOSFETs in the Class-E PA into saturation.

The Clk2 signal from the Si5351A is used as the transmit oscillator as previously mentioned. It would have been easy to enable/disable the Clk2 output in software in the Si5351A chip configuration. However, this transceiver design also includes the built-in signal generator feature, for aligning the Band Pass Filter and adjusting the I-Q balance and phase adjustment controls. So, some of the spare gates in the 74ACT00 are used to switch the signal generator on/off and the RF Power Amplifier (PA) signal on/off, separately.

When the SIG OUT control line from the microcontroller is high, the Clk2 signal is enabled as signal generator, and routed via a 120K resistor straight to the RF input of the transceiver.

A TX signal is produced using IC3D as a plain inverter, to invert the logic level “RX” output from the microcontroller and produce a “TX” signal. This TX signal is used elsewhere in the circuit also (audio muting during TX). R36 pulls the RX signal high during the part of a second at power-up that the microcontroller is booting up and has not yet enabled or switched the RX signal high.

When the TX signal is high, the Clk2 signal is routed to the PA. The final inverting gate IC3A is added to make sure that when the TX gate IC3B is off, the driver voltage presented to the BS170 gate is low, so the transistors are off.

4.10 Class-E Power Amplifier

A Class-E power amplifier is a wonderful thing. It has a very high efficiency, sometimes over 90%. This has several important benefits:

- Since not much power is dissipated, we can use smaller (and cheaper) transistors
- So little power is wasted as heat that the requirement for a heatsink is reduced or eliminated
- During transmit the radio requires less current, so the drain on a battery is less – important for people who want to operate portable.

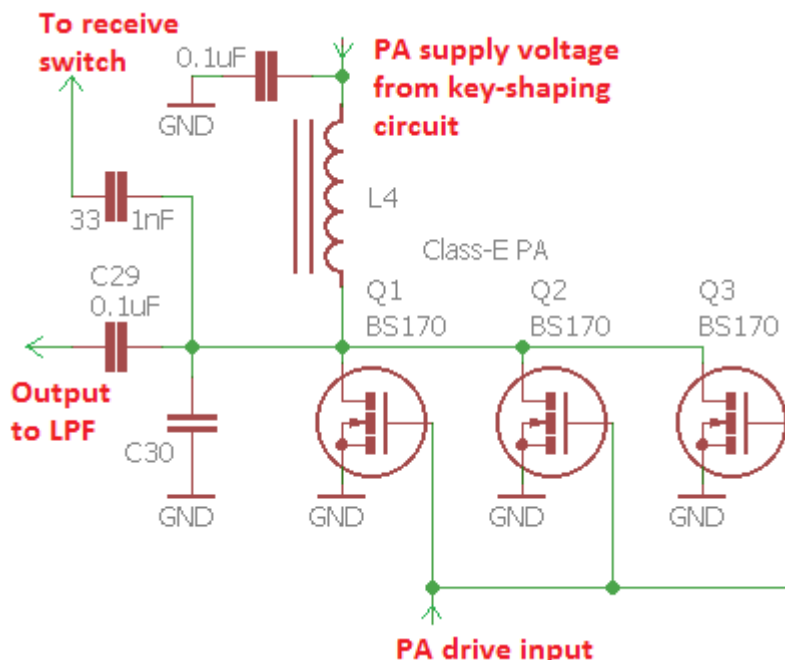

A Class-E Power Amplifier contains a resonant circuit at the frequency of operation, so it is only suitable for single-band use. A lot has been written about Class-E, much of it is very technical and mathematical.

Some excellent background reading are two papers by Paul Harden NA5N:

http://www.aoc.nrao.edu/~pharden/hobby/_ClassDEF1.pdf and
http://www.aoc.nrao.edu/~pharden/hobby/_ClassDEF2.pdf

Paul NA5N describes two defining features of Class-E:

- Use of a square-wave drive to reduce switching losses: the transistors are either on, or off... no lossy region in between
- Reducing the effects of the transistor capacitances. Class-E has a resonant tuned circuit. The capacitance of the transistors, normally an unpleasant lossy aspect, is now a part of the tuned circuit.

Class-E also has a reputation for being difficult to achieve. All those intense mathematics Google will help you find, don't help. In reality, once you realize the secret – it is not so difficult. Calculation of the impedance of a resonant circuit is simple, and there are many online calculators which will do the job for you. For example, <http://toroids.info/T50-2.php> which allows you to type in the operating frequency, and the desired resonant circuit impedance. Then the calculator computes the required inductance, capacitance, and the number of turns required for a certain toroid (in our case we use a T37-2).

The Class-E design process is simple. Choose the output impedance. We choose 50-ohms, because this is the input impedance of the Low Pass Filter we will use. The online calculator will tell you what inductance is needed, and how many turns to wind on the toroid. The online calculator also tells you the required capacitance to bring it to resonance at the operating frequency. Here we resort to experiment, because it is a little difficult to know what the output capacitance of the transistor is. The device capacitance varies depending on supply voltage and whether it is on or off. A simple experiment is required,

adding different small capacitances to the circuit, and measuring the efficiency (measure supply voltage and supply current to calculate power input; then measure RF power output. Divide one by the other to get the efficiency). It is easy to find what additional capacitance is required to peak the efficiency. The resonance is quite broad and non-critical.

In this implementation, three BS170 transistors are used in parallel. The BS170 is inexpensive and small, but is rated for 500mA drain current and up to 830mW of dissipation. Per device. Three in parallel provides plenty of capability to achieve a 5W output on a single band.

There are always minor variations between device characteristics from one transistor to the next. If these were bipolar NPN transistors, we would not be able to parallel them in this way. If one transistor takes more of the load and starts to heat up, its resistance further decreases and this causes it to get even hotter. This process is known as “thermal runaway” and results (quickly) in destruction of the transistor. Emitter resistors are used to help balance the load. But with MOSFETs, their resistance INCREASES as the temperature goes up – so there is an inherent self-balancing when multiple devices are used in parallel, without any need for additional balancing resistors which would increase component count and waste some power.

This oscilloscope screenshot shows the classic Class-E waveform. Please ignore the ringing due to poor set-up of the 'scope probes etc. The lower (blue) trace is the 5V squarewave at the gate of the BS170 transistors. The upper (red) trace is the voltage at the BS170 drain. It peaks at approximately 40V in this example. This measurement was done with 12V supply and on 40m (7MHz).

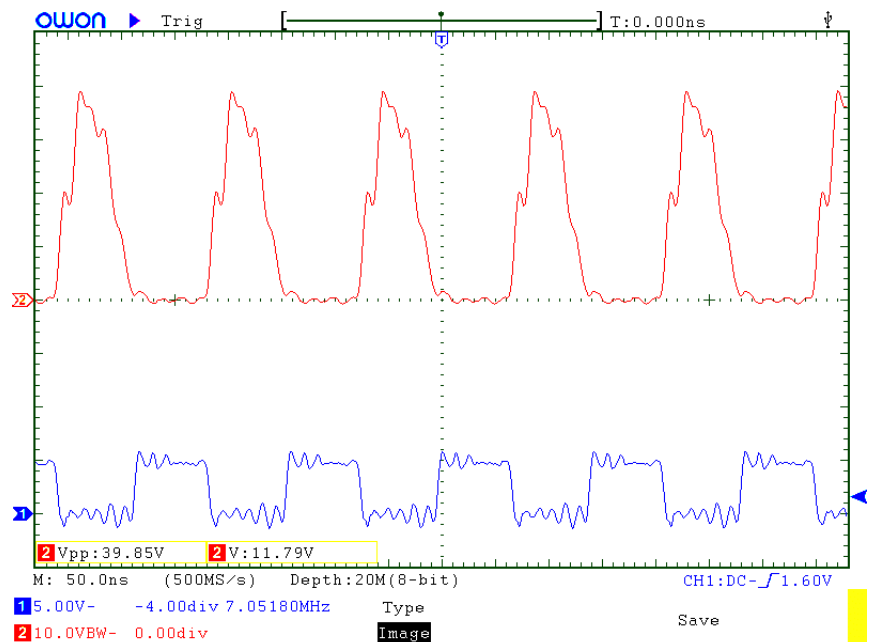

The important point to note is that when the BS170 are switched ON (the gate voltage is 5V), the drain voltage is zero. When the BS170 is OFF the drain voltage pulses nicely to a large amplitude. Class-E!

The summary: Class-E is actually quite easy to achieve in practice! Perhaps all the complicated mathematics might help to squeeze out another % or two of efficiency. But for practical purposes, it's a wonderful building block to use in a single-band CW transceiver.

4.11 Low Pass Filter

The transmitter output is rich in harmonics and must be followed by a good Low Pass Filter, to attenuate the harmonics and satisfy regulatory compliance.

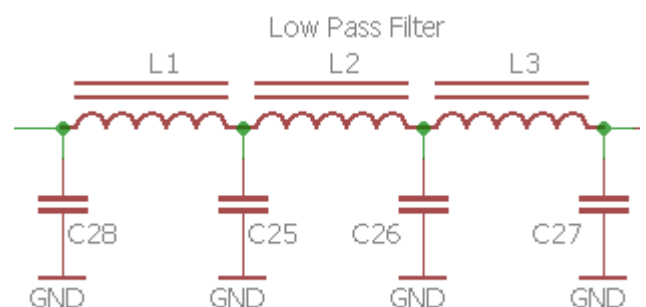

The standard, well-proven QRP Labs Low Pass Filter kit <http://qrp-labs.com/lpfkit> is used here. To save space and cost, the components are installed directly on the PCB, not on a plug-in board.

It is a 7-element filter design originally by Ed W3NQN then published for many years on the G-QRP Club web site's technical pages.

4.12 Key-shaping circuit

A hard-keyed CW transmitter generates clicks many hundreds of Hz away from the transmitted signal that can annoy users of adjacent frequencies. This is purely a consequence of the mathematics of the Fourier transform and is unavoidable. Any time you switch a signal instantly on or off, you WILL splatter energy onto unwanted nearby frequencies.

To combat this, any good CW transmitter should include an RF envelope shaping circuit to soften the key-down and key-up transitions. The ideal envelope shape is a raised cosine, but this is difficult to implement without significantly increasing the complexity of the circuit.

The simple key-shaping circuit used here uses only a few components but produces good results.

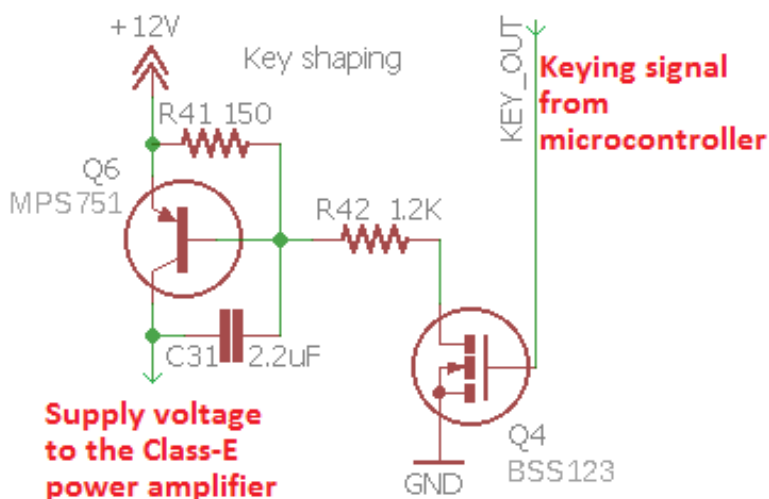

This circuit was derived from one published by Don Huff W6JL, see <https://www.qrz.com/db/W6JL/> though as he says, “*this integrator-type keying circuit is found in many published homebrew designs over the past 40 years or so, so it is nothing new*”. It uses a PNP transistor (Q6) and R-C integrator circuit. Don W6JL uses this key-shaping circuit to drive a 600W Power Amplifier.

On key down the Q4 switch is “closed” by a high signal coming from the microcontroller. In a really simple transmitter, Q4 could just be replaced by a straight Morse key to ground! But in our case, the microcontroller implements automated stored message sending, beacon modes, and Iambic keyer – so we need the microcontroller to be the boss of everything. The microcontroller reads the state of the straight key or paddle, and processes it to produce a key output. When in straight key mode the microcontroller transfers the signal straight through from the key input, to the key output control line – but in other modes the processor must generate the keying signal.

The component values set the rise and fall time. With the components shown, the rise and fall time is about 5 milliseconds.

The following oscilloscope screenshots show a 40m band (7MHz) transmission, keyed with a continuous series of CW dits at approximately 24 words per minute. The amplitude is approximately 3.8W into a 50-ohm dummy load (with 12V power supply).

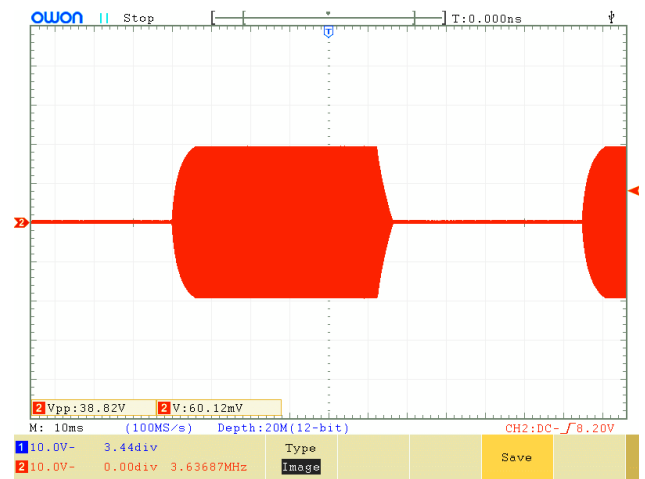
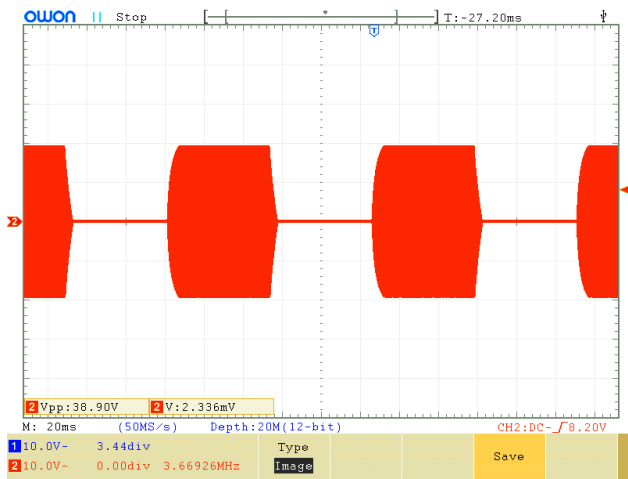

4.13 Microcontroller

The ATmega328 microcontroller circuit controls many aspects of this transceiver. Below is this section of the transceiver circuit. Several points are worthy of discussion.

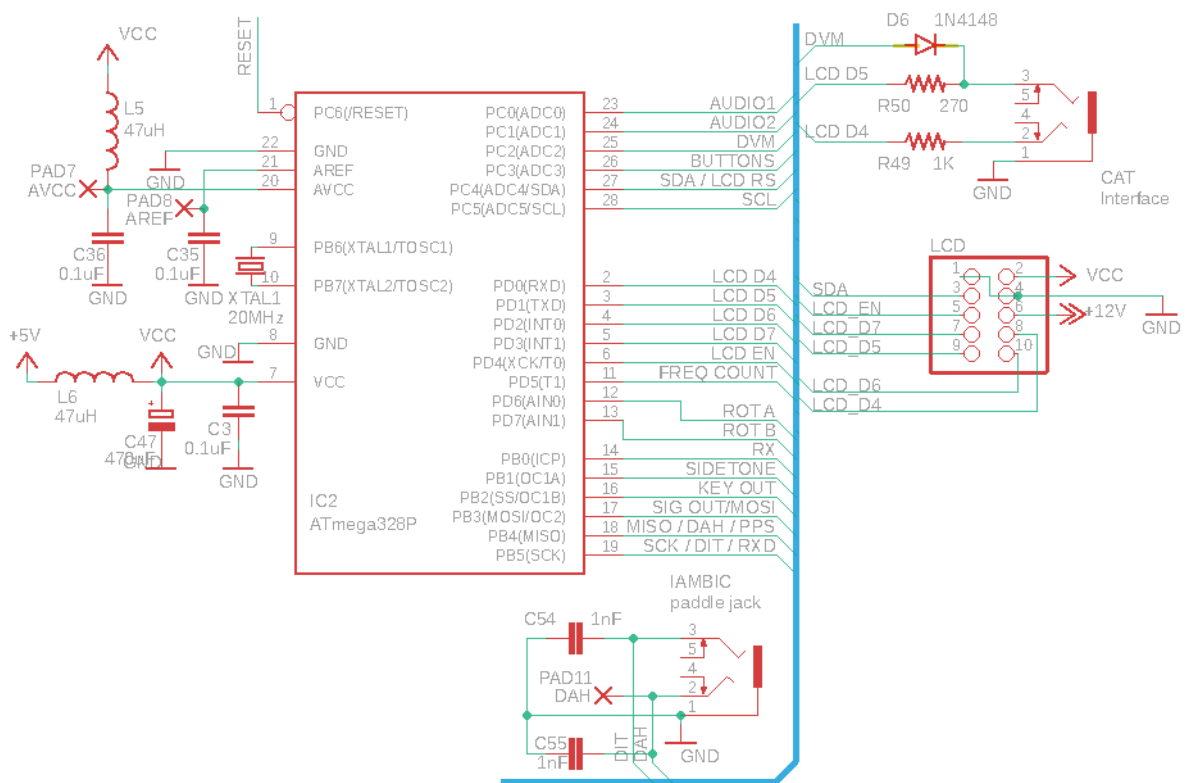

ATmega328P processor

The ATmega328P was chosen because it has enough processing power and I/O to handle all the tasks required here. It is also common and inexpensive, and lots of QRP Labs products already used it, bringing economies of scale in both the kit preparation and the coding. The processor is operated at its maximum rated 20MHz system clock speed.

The code is all written in C and is not open source. While the same ATmega328 processor is used in the popular Arduino Uno products, there is no relation between code written for the Arduino environment and the custom code written for this CW transceiver.

Elimination of tuning clicks

Some constructors of radio receiver projects that use the Si5351A report loud clicks every time the frequency is changed. The cause of these clicks is one or both of two underlying issues:

- a) Faults in the software configuring the Si5351A
- b) Power line or radiated noise from the microcontroller/LCD back into the sensitive receiver

The first of these is not an issue here since we have already extensive experience using the Si5351A and have perfected its configuration.

The second issue is important to address. Every time the microcontroller updates the Si5351A configuration to cause it to change frequency, it typically also writes the new frequency to the LCD. There is a burst of activity in the microcontroller, and on the digital control signals to both the Si5351A and the LCD. The LCD controller chip will also be doing some work to effect the changed display. All of these digital transitions can radiate noise into the receiver front end. Changes in power consumption cause noise on the supply lines which can also be converted into noise detected in the receiver front end.

To combat the radiation issue, the ATmega328P microcontroller is sited away from the RF and audio signal paths, right at the front of the PCB so that the connections between the processor and LCD module and the microcontroller are kept as short as possible, to minimize radiated noise.

To keep noise out of the supply, the 5V supply to the microcontroller and LCD module is filtered by 47uH inductor L6 and 470uF capacitor C47.

In combination, these measures ensure that there are no “clicks” in the audio when tuning the receiver; just a small “flutter” as I call it, which is a natural consequence of the sudden change in frequency (Fourier rules).

Liquid Crystal Display module

The transceiver uses an HD44780-compatible LCD Module with 16 characters by 2 rows. The LCD is operated in the 4-bit mode in order to minimize the I/O pins used. No data is read back from the LCD which means the Read/Write pin can be grounded. In total only 6 I/O pins are used for writing to the LCD.

A yellow/green LCD module is used in the QCX-mini kit because even with the backlight switched off, this type of LCD are still perfectly viewable in ordinary lighting conditions, and even in direct glaring bright sunlight.

The LCD is mounted on the display PCB and the circuit section (below right) is a part of the display PCB.

The usual contrast adjustment trimmer potentiometer is R47 and must be set to obtain a readable display.

The LCD back-light consumes about 15mA of current with a 560-ohms series resistor (at 12V supply). A 270-ohm series resistor was used in the QCX/QCX+ and resulted in 30-35mA current consumption. The larger resistance value was chosen here because the backlight brightness really does not need to be extreme, and for portable operations on battery power, minimizing current consumption is more important.

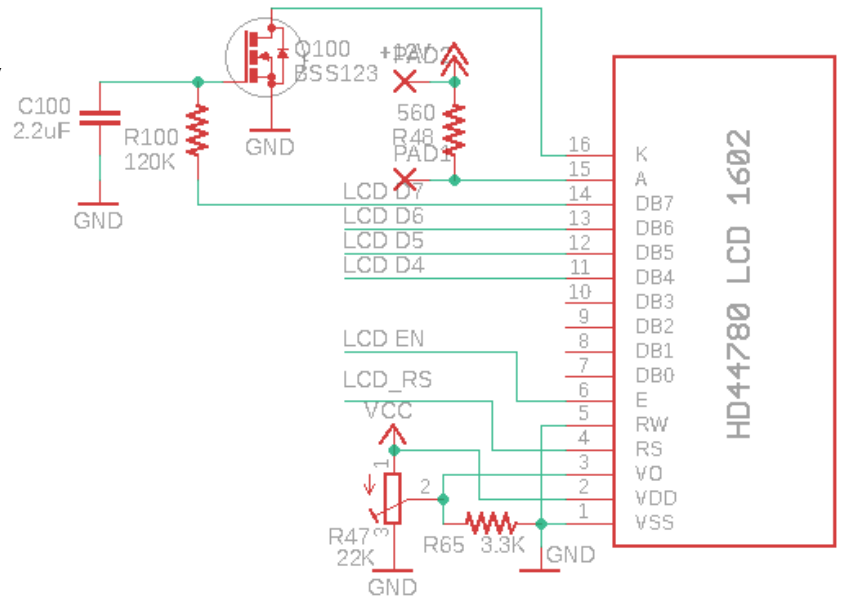

The back-light could be connected directly to the 5V supply but this would somewhat increase the power dissipation of the 5V voltage regulator. In order to avoid overheating the regulator, this back-light is powered instead directly from the +12V rail via R48, a 560-ohm resistor.

A different resistor value could be installed for the LCD backlight series resistor; large pads are provided on the PCB for this purpose (facilitating easy installation of a standard through-hole ¼W resistor).

Unlike its predecessors the QCX and QCX+, the QCX-mini transceiver has a means to switch on or off the backlight under firmware control, via the configuration menu. This is achieved using LCD data pin 7. Whilst this pin is used for communication from the microcontroller to the LCD module, this is only a brief data burst lasting a few microseconds. The rest of the time, the pin can be left in a high or low state, under processor control.

MOSFET Q100 is used as a switch, in series with the backlight LCD. It is switched ON by +5V on the gate pin. However, to avoid potential RF noise getting back into the sensitive QCX-mini receiver circuits, capacitor C100 and resistor R100 form an integrator, the effect is to filter out the burst of data that occurs when the microcontroller writes to the LCD. The time constant is 0.26 seconds. Its very slow, plenty slow enough for the data burst to be totally ignored by the LCD, and therefore no RF interference is generated.

Sidetone

In the early firmware versions of this transceiver, the sidetone was generated by Pulse Width Modulation using the ATmega328's Timer1 peripheral. The frequency and volume of the sidetone were configurable in the software via the configuration menu. In order to control the volume, the microcontroller adjusted the duty cycle from 50% (maximum volume) down to under 1% (for minimum volume).

In firmware version > 1.02 and above, the sidetone generation method was changed. The former method was a simple squarewave, with variable duty cycle, in order to change the volume. However, this also changed the average level, leading to a DC bias at low volume levels; on switching from Transmit to Receive (and indeed, vice versa), the DC bias through the audio chain, being suddenly restored the nominal 2.5V, generated a large click.

The resolution to this was generation of sidetone by superimposing a PWM duty cycle change, for example from 51% to 49%, on a much higher frequency squarewave (42kHz is used at 700Hz for example; the higher frequency is given by 60 x sidetone frequency). This duty cycle change at a rate of 700 times per second, creates a small 700Hz squarewave superimposed on a full size 42kHz squarewave; the average duty cycle is 50% and therefore no click occurs during RX TX switchover. The volume is changed for example, made louder, by a larger change in duty cycle; for example 60/40% instead of 51/49%.

The sidetone is injected into the receiver path via a 3.3K resistor at the input to the CW filter. The sidetone generated by the microcontroller is a squarewave, rich in harmonics. As the volume is reduced, the duty cycle percentage drops and the amplitude of the 700Hz fundamental tone also drops. There are many harmonics of course, and the CW filter does a great job of removing these, so what is left in the earphones is a pleasant and pure 700Hz sinewave. This is why the sidetone is injected at the CW filter INPUT.

During transmit, when the sidetone is operational, the mute switch Q7 is also closed – but there is enough leakage through the imperfections of this switch that the sidetone gets through anyway. The 3.3K sidetone feed resistor R59 is chosen to pump enough signal through that it overcomes the attenuation of the mute switch. Without the mute switch, R59 would be a much higher value.

Key paddle, rotary encoder switch buttons

The microcontroller keeps an eye on all the buttons, key paddle inputs, and rotary encoder switches. When button or switch closures occur as the operator activates a control, the microprocessor responds immediately as required.

The paddle inputs, and the rotary encoder switch, are read using dedicated microcontroller I/O signals. In PCB Rev 3, the paddle inputs each have a 1nF capacitor to ground, whose purpose is to get rid of any stray RF that may have been picked up on the paddle cable. The correct solution to this problem is really to fix the antenna using a choke to suppress common mode feedline currents (“RF in shack”) however in recognition of the fact that in portable situations sub-optimal antennas may often be used, the capacitors were added to resolve any potential issues.

All mechanical switches exhibit switch bounce, where the switch contacts generate multiple transitions for a short time when the switch is activated. It is common to see in many projects, resistor-capacitor networks to debounce switches (including the rotary switch). Simple debounce circuits involving a resistor and a capacitor inevitably involve a compromise when choosing the R-C time constant. It is easy to miscalculate and make the time constant too short (bounce noise still gets through) or too long (rapid switch closures are missed). In some cases it is impossible to find the sweet spot in between these two extremes.

In my opinion, resistor/capacitor debouncing is a poor solution to the problem, when the circuit contains a microcontroller. It is easy to debounce the switch edges in software! This allows you to control time-constants or other debounce logic much more precisely. Of course, it saves those additional resistors and capacitors too, which all helps reduce the cost and complexity of the kit! This is the

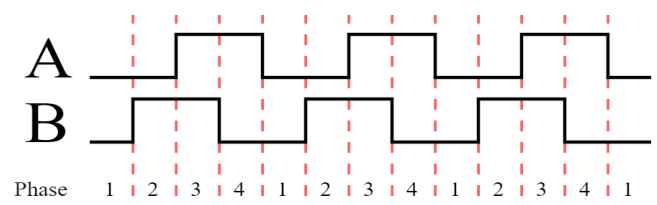

reason why in this kit, you will not see any resistor or capacitor debouncing of any of the controls. Everything is done in the software.

The rotary encoder is debounced using a state machine, rather than any timing loops. The rotary encoder produces two switch-closure outputs which have a 90-degree (quadrature, again) phase shift. The microcontroller can monitor these transitions and determine the number of “clicks” of the rotary encoder, and the direction the knob was turned in, and at the same time debounce the switch transitions.

Another unnecessary component often seen is a pullup-resistor on a switch signal to a microcontroller, so that when the switch is open (not pressed) the microcontroller sees a “high” voltage. This is unnecessary because modern microcontrollers such as the ATmega328P all contain configurable internal pull-ups!

I had a little more trouble when it came to the “Select”, “Rotary” (shaft of the rotary encoder) and “Exit” push-buttons. Despite thinking that the microcontroller had plenty of I/O signals available, when I came to implement all the features I had in mind, I realized there weren’t enough I/O signals to read the buttons!

The solution was to analogue-multiplex all three buttons onto a single input signal to the microcontroller, which is one of the Analogue to Digital Converter (ADC) channels. No microcontroller internal pull-up is used because I need to have precise control over the voltage levels.

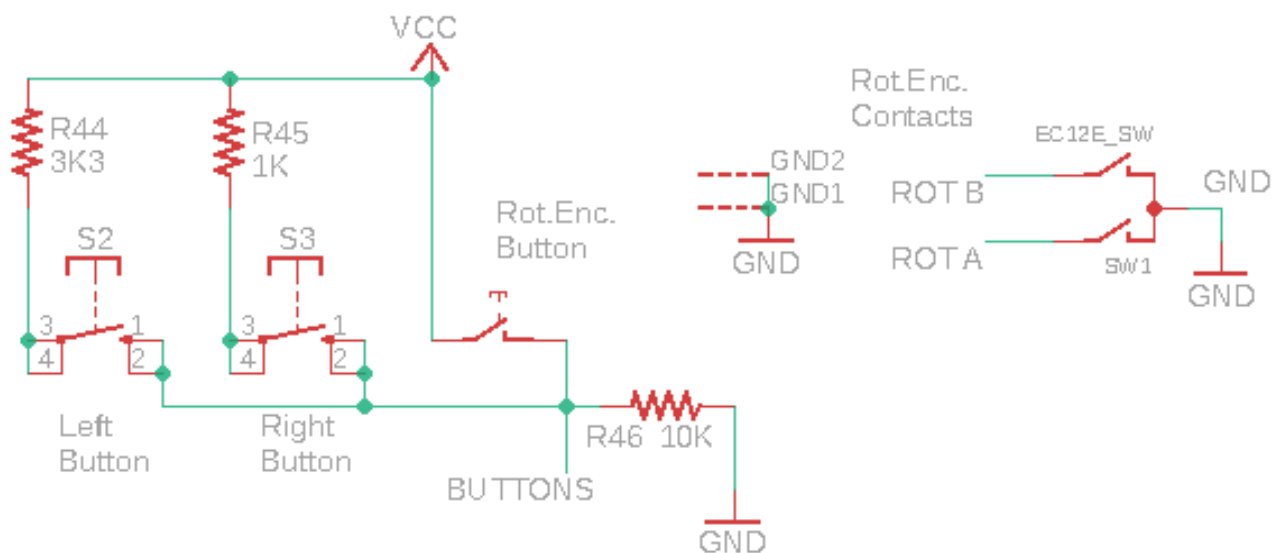

The circuit fragment above shows the rotary encoder, and the three buttons (two tactile switch buttons, plus the button internal to the rotary encoder shaft) which are located on the front panel PCB.

Note that in PCB Rev 3, there are additional R-C filters on the ROT A and ROT B signals containing a series 10K resistor and 10nF capacitor to ground; these are shown on the schematic of the whole front panel board. The purposes of these filters is to suppress clicks that occur on tuning. The clicks are at a low level and not normally audible except on dummy load (on an antenna, the band noise normally masks the clicks). The exact origin of these clicks is unclear and they do not occur on the QCX+ and QCX-classic. Tests were undertaken that prove the clicks do not arise due to microphony and neither are they due to a PCB layout issue. Anyway, the R-C filtering attenuates them greatly.

The input signal is pulled low by a 10K resistor R46. One side of all three buttons is connected to the I/O pin. The other sides of the buttons are connected to 5V via different

resistors: 3.3K (R44) for the left (“Select”) button, 1K (R45) for the right (“Exit”) button, and direct connection for the center (“Rotary”) button. When one of the buttons is pressed, the resistors form a potential divider that sets the voltage to the microcontroller depending on which button is pressed. Some calculation results in the following table of voltages depending on which button is pressed:

Button pressed	Voltage
None	0.00V
“Select”	3.76V
“Rotary”	5.00V
“Exit”	4.55V

In all three cases, the voltage when a button is pressed, is higher than the 3V logic “1” threshold of the microcontroller. I am able to use a pin-change interrupt to detect that a button has been pressed, then read the ADC channel 3 and compare the measured voltage to the table, to determine which button was pressed.

It’s a nice trick for reading multiple buttons on a single ADC input, and it would work also for a larger number of buttons! Each one just needs a different resistor value and eventually, some care would need to be taken to ensure that the voltage differences could be read reliably, not masked by ADC noise or component inaccuracies. For three buttons, none of these problems arise.

TX/RX Switch control, and Key Out signals

As already discussed, the Key Out signal either reflects directly the state of a straight key, in Straight keyer mode, or it is a processed keyer signal when using the Iambic keyer modes or Beacon function of the transceiver. The Key Out signal is generated by the microcontroller with precise timing in the Beacon and Iambic keyer modes. It is routed to the RF envelope key-shaping circuit discussed previously.

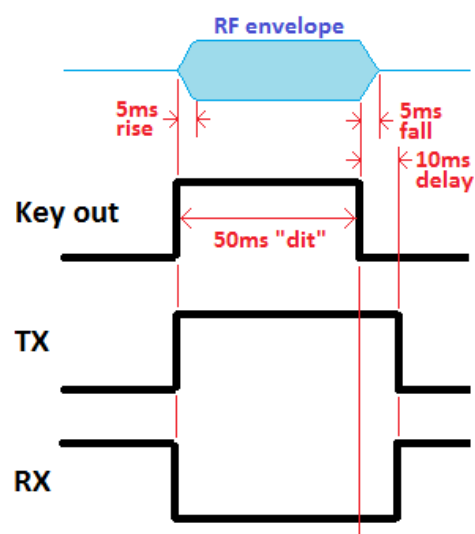

The Transmit/Receive switch must remain in “transmit” state for a short time after key-up, in order for the RF envelope of the key-shaping circuit to drop gently down to zero, which takes approximately 5ms. Due to this, the microcontroller implements a 10ms delay between key-up and switching the radio back to receive mode.

The diagram (right) illustrates the relationship between these signals, for an example 24 words per minute “dit”. The Key out signal has a “high” period of 50ms exactly. The ramp-up and ramp-down of the RF envelope has 5 millisecond (approximately) rise and fall times. The “RX” control line generated by the microcontroller switches on the receiver (allows RF through to the receive mixer) when it is “high”. It is held in the “low” (transmit) state for 10ms after key up completes.

The “TX” signal is the inverse of the “RX” signal, and it switches the gate of the audio mute switch Q7 during transmit. One of the NAND gates IC3D is used as the inverter to create the “TX” signal from the microcontroller’s “RX” output.

4.14 Optional GPS interface

The GPS was a late addition to the design. It is added to facilitate several useful features:

- Calibration of the 27MHz reference oscillator
- Calibration of the 20MHz system clock
- For WSPR, discipline of the frequency (drift correction)
- For WSPR, setting and discipline of the real time clock
- For WSPR, setting the Maidenhead Locator square

The optional GPS interface is provided by the same connector as the paddle (Serial, PPS and Ground); +5V is available at the tip connection of the PTT connector. The QLG1 GPS receiver kit is ideal for the QCX-mini. However other GPS modules could also be used. The following requirements of the GPS module must be met:

- Positive-going (leading edge) 1 pulse per second signal with a reasonable pulse width – e.g. some older GPS modules have a 1µs pulse and this will not be long enough. The QLG1 GPS receiver provides a 100ms (0.1s) duration pulse, though shorter pulses would also work.
- 9600 baud serial data sending standard NMEA 0183 GPS sentences
- “TTL” voltage levels i.e. 0V “low” and 5V “high” (or at least, below 1.5V and above 3.5V)

The GPS is therefore wired directly in parallel with the paddle. The GPS may not be used at the same time as the paddle. This would cause the transmitter to be keyed by the 1pps and serial data signals. **Always put the kit into Practice Mode (see menu 4.7) before connecting a GPS, to avoid accidentally frying the PA.**

The ATmega328P has a USART serial data peripheral. However, the pin assignments were already made, so far down the design process, at the time the GPS receiver option was included. Furthermore, the I/O pin availability was already scarce. So, the two GPS signals share the same I/O as the paddle inputs. A software-emulated USART peripheral module now reads the GPS serial data, at 9600 baud.

If you connect a GPS and forget to put the kit in practice mode, it will automatically recognize serial data at the paddle input and temporarily enable practice mode (an ‘A’ appears in the display) to protect the PA circuit.

4.15 In Circuit Programming (ISP) interface

A 2x3-pin header is installed on the PCB to facilitate In Circuit Programming (ISP) of the ATmega328P microcontroller in future, if new firmware versions become available.

Firmware updates can be done with a simple USBASP AVR programmer available from eBay for under \$2 including international shipping. The 2x3-pin header pinout matches the standard AVR programmer cables.

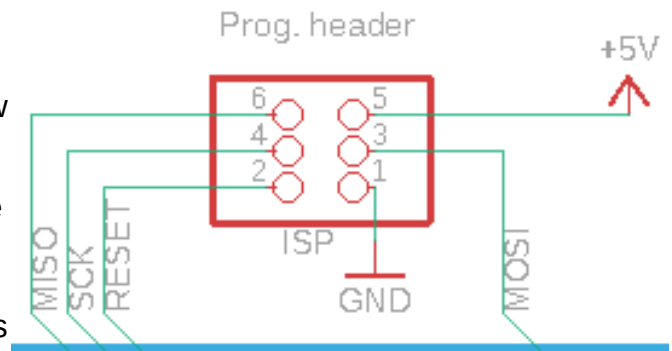

The ISP interface uses the same I/O pins as the GPS interface and the Paddle. When upgrading the firmware, be sure to disconnect the GPS (if you had one connected). And do not press any paddle key while doing the firmware update!

Some AVR programmers require a 5V connection to sense the target programming voltage; some do not. +5V is connected to pin 5 of the ISP header. If you do not want this connection in your particular case, you would need to cut the track to this pin

4.16 Test Equipment

The built-in test and alignment equipment is a really nice feature of this CW transceiver kit.

DVM and RF Power meter

The DVM and RF Power meter is implemented using the 10-bit ADC channel 2 input to the microcontroller.

When measuring voltage, connect the voltage to be measured to pin 3 of the 4-pin DVM/RF Power connector. The voltage is dropped by the potential divider formed by R56 (3.3K) and R57 (10K). This applies a division by a

factor of 4.03. Since the ADC can measure voltages up to 5V, this means the DVM function has a range of 0V to 20V maximum, and each ADC bit has a resolution of 0.02V.

When measuring RF power, connect the RF to be measured to pin 2 of the 4-pin DVM/RF Power connector. In this case D4 and C42 form a simple RF detector. The RF is rectified by D4 and smoothed by C42. R56 (3.3K) and R58 (10K) again form a potential divider that divides the rectified voltage by a factor of 4.03. The resulting range of the power meter is from 0 to 5W approximately.

For normal operation of the radio, if you wish to see a battery voltage icon on screen, then connect pin 1 to pin 3 of the 4-pin header. This connects the voltmeter input to the 12V supply of the radio.

In the unlikely event of accidentally overloading the RF power input or the DVM input, the 10K resistors R57 and R58 limit the

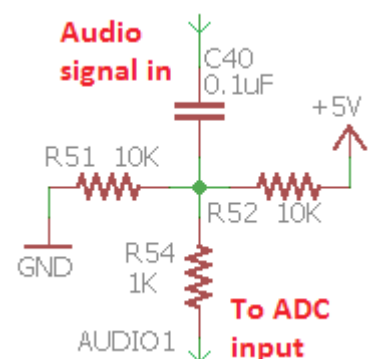
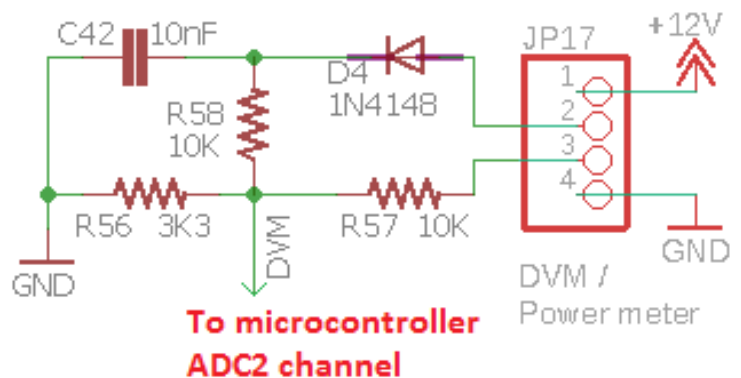

damage to the ATmega328P processor or maybe prevent damage altogether. Perhaps. (don't feel tempted to try it intentionally).

Audio ADC

There are two audio connections from the receiver signal chain to the microcontroller. One is connected at the output of the I-Q balance adjustment potentiometer. In other words, the input to the CW filter. The second audio connection is connected after the final audio amplification gain stage. Both of these audio signal channels are fed to Analogue to Digital Converter (ADC) inputs of the microcontroller.

The circuit diagram (right) shows the circuit at AUDIO 1 (ADC channel 0) which is connected to the audio amplifier output. The purpose of the circuit is to remove the DC bias from the audio signal, and apply a new bias of 2.5V, to bias it to the middle of the ADC's input range. The 1K resistor in series with the ADC pin is intended to provide some kind of limited protection to the microcontroller in the event that the voltage falls outside the range 0-5V. A simpler circuit is used on the AUDIO 2 channel as the DC bias is already 2.5V so the signal is within the range 0-5V.

The ADCs in the ATmega328P have 10-bit resolution which translates to about 5mV. The ADC conversion result is a number in the range 0-1023, with 512 representing zero. An audio voltage of +/- 2.5V can therefore be measured. In practice, the audio signal is much less than this, which means the full ADC range is not really used. The AUDIO2 channel (connected at the CW filter input) has even less amplitude so is not used for anything except the BPF Alignment procedure, which has a very strong signal.

Frequency Counter

The frequency counter test pin input is connected directly to the microcontroller's 16-bit Timer1 input pin.

There is a 1K series resistor (R55) to connect it also to the Si5351A's Clk2 output. This is used during the optional GPS-disciplined 27MHz reference crystal frequency measurement. In this function, the Si5351A is configured to route its raw 27MHz output, divided by 4, to its Clk2 output. This passes through the 1K resistor R55, to the microcontroller. The 1K resistor provides protection to the Si5351A in the event you accidentally have something connected to the FREQ input pin, and the Si5351A is operating its Clk2 output at the same time.

Since the 3.3V peak-peak signal from the Si5351A is rather marginal for operating the Timer1 input, a 3.9K pullup resistor increases its center point. Now "low" is 1.02V and "high" is 3.65V, which is enough to trigger the Timer1 input reliably.

The frequency counter can operate from 0 to 8MHz theoretically, assuming a clean 50% duty-cycle squarewave signal of sufficient amplitude. The 8MHz upper bound is a limitation of the AVR processor which has a synchronous timer input, and can only count to 40% of the system clock frequency (40% of 20MHz is 8MHz).

The signal to be counted must satisfy the logic thresholds of the ATmega328P, namely a "low" or "0" is less than 1.5V, and a "high" or "1" is greater than 3.5V.

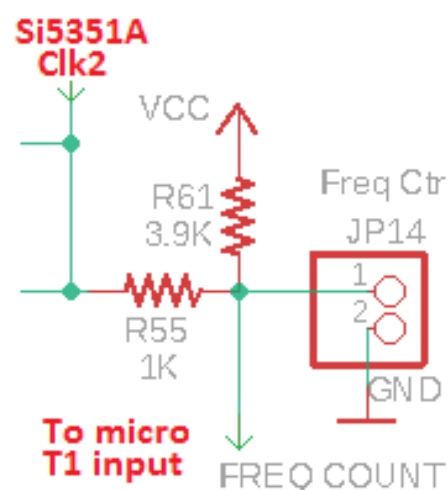

Signal Generator

The signal generator mode was also discussed in the operating manual section. The signal output is taken from the Clk0 or Clk1 output of the Si5351A (there are no pads for this). Care should be exercised not to draw excessive load (e.g. short circuit) from these pins, which could damage the Si5351A. It will be very difficult to replace a damaged Si5351A.

Self-test of Signal Generator and Frequency Counter

Note that once the Signal Generator has been activated by scrolling to the Signal Generator menu item, and pressing the “Select” button to enable it – the Signal Generator remains active on the set frequency, until you press the “Exit” button and leave the Test Equipment menu.

Press the “Select” button to enable the signal generator; an underline cursor appears under the digit that will be tuned by the rotary encoder. Adjust the signal generator to produce a frequency some way under 8MHz. Let’s say, 6MHz. When you leave edit mode, by pressing the “Select” button until the cursor disappears off the right side of the 1’s digit, OR by pressing the “Exit” button, then the cursor will no longer be shown on the display. Turning the rotary encoder 1 click anticlockwise shows menu 9.5, the frequency measurement. Now if you connect a wire from the FREQ input to the CLK0 output, you will measure the signal generator’s frequency. This is shown here in the photograph (right, original QCX not the QCX-mini); clearly the 2kHz low reading indicates I have not calibrated the 27MHz reference value and/or the 20MHz system clock value!



In the photograph, the white wire shown looping around the rotary encoder connects the FREQ pin (just under the “M” character of the LCD, in the photograph) to the Clk0 output pin (just under the “z” character of the LCD).

This is a convenient way to get the frequency counter to verify the correct operation of the signal generator (and hence the Si5351A synthesizer). The signal generator output is available at both the Clk0 and Clk1 pins, hence you can test them both.

4.17 5V voltage regulator

5V for the microcontroller, Quadrature Sampling detector chip, LCD module and IC3 (quad NAND gate) is provided by IC11, a AMS1117-5.0

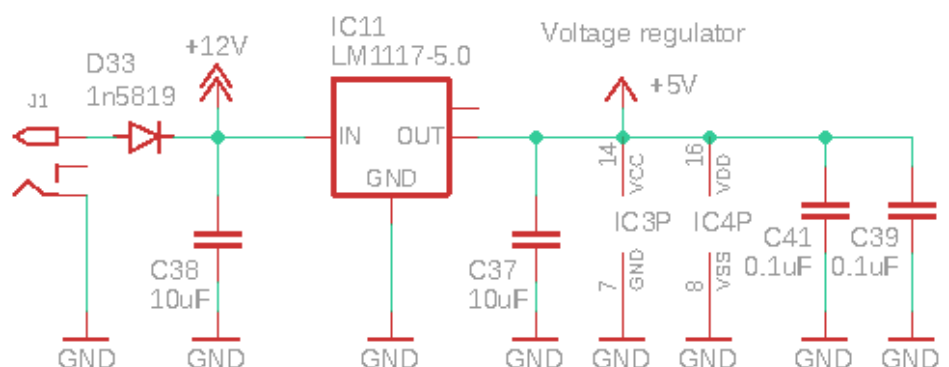

5V 1A voltage regulator. In PCB Rev 2 and above, the regulator has been changed to 78M05 which is more robust.

Note that the input is protected against reverse polarity by D33, a Schottky diode type 1N5819. This also drops the voltage by 0.3 to 0.4V, which has the effect of reducing the output power. D33 is shown on the microcontroller section of the circuit diagram, see earlier.

If you are brave, and confident that you will NEVER connect power to the radio with reversed polarity, you can omit this diode and fit a jumper wire over it.

5. Fault-finding

Refer to <http://grp-labs.com/qcx/qcxtrouble> and the groups.io discussion group for more tips!

5.1 Blank LCD or blocked LCD

If your LCD screen looks like either of these, then it is a sure sign that you have not adjusted the contrast trimmer potentiometer R47.

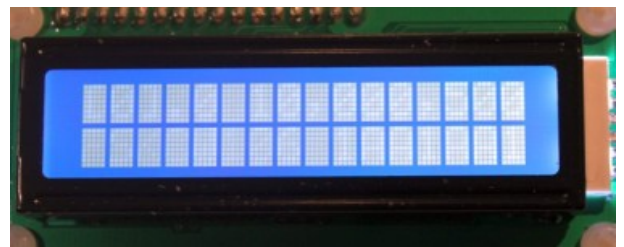

5.2 No back-light at all

If there is no LCD back-light at all, check you have properly installed the LCD connector between the main PCB and the LCD board.

No back-light can also be NORMAL! If the backlight setting in the “Other” menu configuration (in menu 7) is set to OFF, then the backlight will be off, naturally. The QCX-mini screen is readable without the backlight so it will be no problem to change this menu entry.

5.3 A row of blocks appears on the top row

If you see a row of blocks along the top of the LCD module, and the bottom row is empty, this means that the microcontroller has not communicated with the LCD module.

Check that your IC2 microcontroller is correctly installed in its 28-pin socket, with the correct orientation (dimple on the chip matches the dimple on the socket and the PCB silkscreen). Check that all of the pins of IC2 are correctly inserted in the socket, not bent.

5.4 DC voltage readings

The following table lists the DC voltage read at various points around the circuit. This may aid troubleshooting. The voltage measurements were made using the in-built DVM, in menu item 9.1. These measurements were made using a 12V power supply.

Where an IC pin number is mentioned, remember that pin numbers start from the top left (just to the left of the dimple at the end of the chip) and are counted anticlockwise from there (see diagram of 8-pin IC, right).

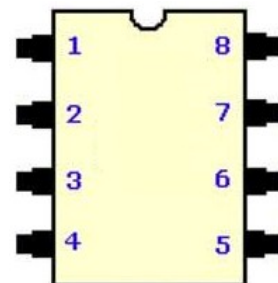

Where “left”, “right”, “top” and “bottom” are mentioned, they assume the PCB is orientated in the normal way.

All measurements were made probing the PCB from the top side. In some cases, poke the wire to touch the pad of a particular capacitor or resistor.

References to the pinout of transformer T1 use the nomenclature indicated in the diagram (right).

In many cases these measurements may not exactly match your own. In particular if you use a power supply other than 12V, then voltages which are derived from the 12V supply line will be different. For example, bias voltages on op-amps which are biased to half the supply rail.

Bear in mind that in some of these measurements, the act of measurement will itself change the measurement. The “input resistance” of this DVM is only 13.3K (R56 and R57 in series, assuming high input resistance of the microcontroller pin). If you were to make these DC measurements with a high input resistance “real” DVM rather than the inbuilt DVM of this radio transceiver, these measurements would change. Again: if your measurement is in the right ballpark, do not worry if it differs from these.

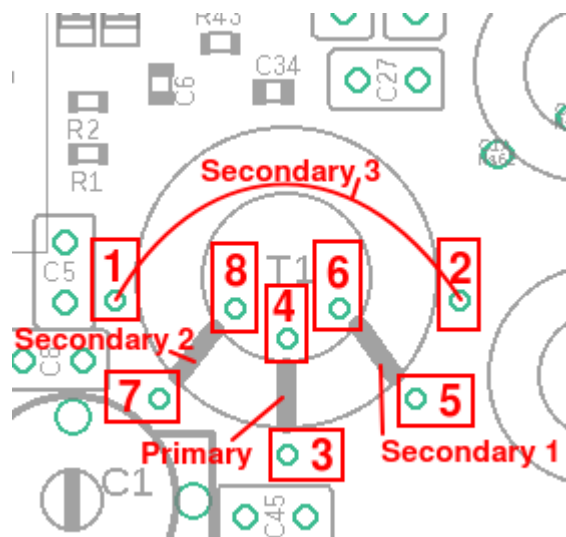

When making these measurements, be very careful that whatever wire you are using to probe the circuit does not cause shorts to adjacent pins or components, which could cause damage.

I suggest avoiding directly probing the Si5351A chip pins, they are just too small: the risk of shorting adjacent pins is high. You can easily probe nearby components which are connected to the Si5351A pins, if you wish – refer to the PCB tracks diagram. Similarly, I do not recommend directly probing the FST3253 pins. Again, it is easy to probe nearby components which are connected to those pins, and reduces the risk of damaging something by causing inadvertent short circuits.

Location	Voltage	Comment
+ supply terminal	11.98	As I already mentioned: a 12V supply
Clk0, IC1 pin 10	~1.70	The Clk0 pin in normal operation has a 3.3V peak-peak squarewave with 50% duty cycle. The DVM is measuring the average of that. Measuring here makes a lot of nasty noise in the audio.
Clk1, IC1 pin 9	~1.70	The Clk1 pin in normal operation has a 3.3V peak-peak squarewave with 50% duty cycle. The DVM is measuring the average of that. Measuring here makes a lot of nasty noise in the audio.
Pair of pads near IC1 pins 5 and 6	3.40	This is the voltage of the Si5351A supply, pins 1 & 7
Top end of D2	4.96	This is the +5V regulated supply
T1 pins 1, 2, 3 & 4	0.00	
T1 pins 5, 6, 7 & 8	2.36	
Left side of C43	2.28	C43-46 are the QSD integrating capacitors. The voltage across each one differs slightly. The following measurements show these small differences.
Left side of C44	2.44	
Left side of C45	2.42	
Left side of C46	2.30	
IC5 pin 1	2.64	IC5a output, the pre-amp I output
IC5 pin 2	2.46	
IC5 pin 3	2.26	
IC5 pin 4	0.00	
IC5 pin 5	2.28	
IC5 pin 6	2.46	
IC5 pin 7	2.44	IC5b output, the pre-amp Q output
IC5 pin 8	11.67	This is the supply voltage minus the voltage drop caused by reverse polarity protection diode D33
IC6 pin 1	2.44	IC6a output
IC6 pin 2	2.44	
IC6 pin 3	1.63	
IC6 pin 4	0.00	
IC6 pin 5	1.55	
IC6 pin 6	2.44	
IC6 pin 7	2.44	IC6b output
IC6 pin 8	11.67	
IC7 pin 1	2.64	IC7a output
IC7 pin 2	2.64	
IC7 pin 3	1.99	
IC7 pin 4	0.00	
IC7 pin 5	1.89	
IC7 pin 6	2.64	
IC7 pin 7	2.64	IC7b output
IC7 pin 8	11.67	
IC8 pin 1	2.46	IC8a output
IC8 pin 2	2.46	
IC8 pin 3	0.65	
IC8 pin 4	0.00	
IC8 pin 5	0.67	
IC8 pin 6	2.48	

IC8 pin 7	2.48	IC8b output
IC8 pin 8	11.67	
IC9 pin 1	4.84	IC9a output
IC9 pin 2	4.84	
IC9 pin 3	0.65	
IC9 pin 4	0.00	
IC9 pin 5	0.67	
IC9 pin 6	2.44	
IC9 pin 7	2.44	IC9b output
IC9 pin 8	11.67	
IC10 pin 1	5.83	IC10a output
IC10 pin 2	5.83	
IC10 pin 3	5.83	
IC10 pin 4	0.00	
IC10 pin 5	4.21	
IC10 pin 6	3.94	
IC10 pin 7	5.83	IC10b output
IC10 pin 8	11.67	
LCD pin 1 (leftmost)	0.00	LCD VSS supply pin
LCD pin 2	4.94	LCD VDD supply pin
LCD pin 3	0.57	LCD Contrast
LCD pin 4	4.92	LCD RS pin
LCD pin 5	0.00	LCD RW pin
LCD pin 6	0.00	LCD E pin
LCD pin 7	1.08	LCD DB0 pin
LCD pin 8	1.08	LCD DB1 pin
LCD pin 9	1.06	LCD DB2 pin
LCD pin 10	1.04	LCD DB3 pin
LCD pin 11	0.00	LCD DB4 pin
LCD pin 12	4.94	LCD DB5 pin
LCD pin 13	4.92	LCD DB6 pin
LCD pin 14	0.00	LCD DB7 pin
LCD pin 15	4.41	LCD back-light anode
LCD pin 16 (rightmost)	0.00	LCD back-light cathode

5.5 RF Power output check

If you go into menu “9.2 RF Power”, you can check your RF power output. Your RF output should be connected to a dummy load, since the RF power calculation assumes that the voltage is across a 50-ohm load.

Only connect the RF probe (pin 2 of the 4-pin DVM/RF Power header) to the RF output of the QCX-mini; this should be connected at the junction of C28 and L1, or the center pin of the RF connector, etc. Measurement of power at other points in the transmitter power amplifier, or intermediate junctions in the Low Pass Filter, will be invalid because the impedance at those points will not necessarily be 50-ohms

On key-down, the display will read the power output in Watts. It is easiest to have the transceiver in Straight key mode and squeeze the paddle.

Remember that the simple diode RF detector is not likely to be particularly accurate. But if you see a reading of a few watts, it will give you confidence that your transmitter is working properly.

If you do NOT see any power output on key-down, then you probably have a fault in the Power Amplifier. A common mistake, as I mentioned previously during the assembly steps, is failure to remove or burn off the enamel insulation on the enameled copper wire wound onto the toroids.

Check the RF power wire touched to the BS170 drains first (see diagram). You can still touch the wire to these BS170 drains from the top side of the board. Key-down and check the wattage reading. At this point the indicated power will be even less reliable than across the dummy load. But at least see if it reads some watts.

If you see power output at the BS170 drains, but not at the overall transceiver RF output, then this means that the fault lies in the Low Pass Filter. Check the soldering and the enamel situation, on those toroids.

If you do not even see power output at the BS170 drains, then perhaps the L4 drain inductor in the PA has incorrectly soldered wires, that have not made an electrical connection – so check the L4 wires first and make sure the enamel is properly scraped or burnt off, to make a proper connection.

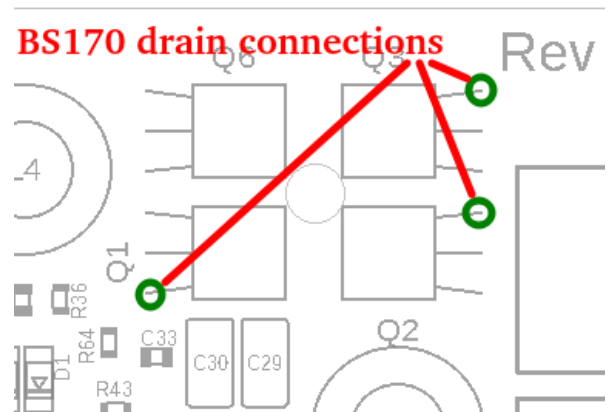

6. Measurements

The measurements in this section were performed on assembled kits. There will always be differences from one kit to the next, due to component tolerances, adjustment differences, how you wound toroids, etc. In addition, it is often difficult to make good RF measurements. Therefore, everything you read in this section should be interpreted as an INDICATION only. Your actual results may (and probably will) differ. The following information just gives a guide of very roughly, what you might expect to see.

6.1 Equipment

For reference, and for the sake full disclosure, the following equipment was used in making these measurements:

- OWON XS3102A 12-bit 100MHz Digital Storage Oscilloscope
- ADVANTEST R3361C 2.6GHz Spectrum Analyzer with 50-ohm tracking generator
- QRP Labs 50-ohm Dummy Load kit <http://qrp-labs.com/dummy>
- XONAR U5 24-bit external USB sound card
- Argo and Spectran audio analysis software from <http://weaksignals.com>
- QRP Labs Ultimate3S for test signal generation <http://qrp-labs.com/ultimate3/u3s>
- Simple 14.000MHz battery-powered crystal oscillator signal generator
- Two generic yellow DVMS
- 12V fixed power supply, and variable voltage bench supply

6.2 Transceiver current consumption

The current consumption of your radio may be an important consideration if you intend portable battery-powered operation. Current consumption depends on supply voltage.

These measurements were carried out on a 40m band version of the kit. They will not differ much for other bands. The receive current graphs shows measurements with and without the LCD backlight. The transmit current graph below is measured with the backlight off.

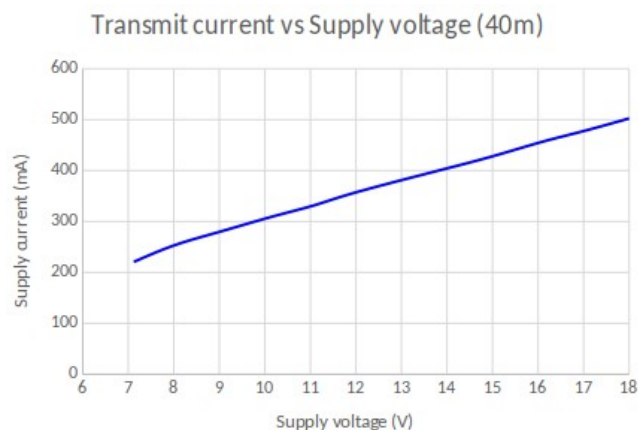
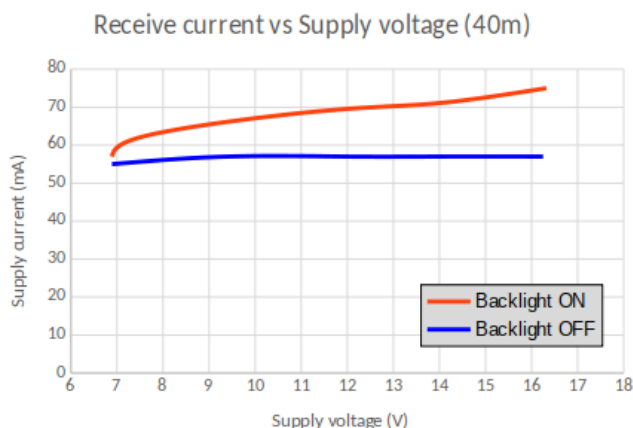

6.3 Transmitter power output

The transmitter RF power output varies depending on the power supply voltage. It is also dependent on band. Your results may vary depending on your Low Pass Filter inductor construction! If the cut-off frequency becomes too low, then you can start to get attenuation at the operating frequency. In this case you can remove a turn or two from each toroid.

The following charts show the power measurement using the oscilloscope to measure the peak-peak amplitude across the 50-ohm dummy load.

Operation at output power levels above 5W is NOT recommended, as it will put too much strain on the BS170 output transistors which may result in failure. For this reason, limiting the supply voltage to not more than 14V.

Note that these measurements do not take into account the D33 1N5819 reverse polarity protection diode voltage drop (approximately 0.3 or 0.4V). In other words, the measurements were done in a transceiver with D33 bypassed by a wire link.

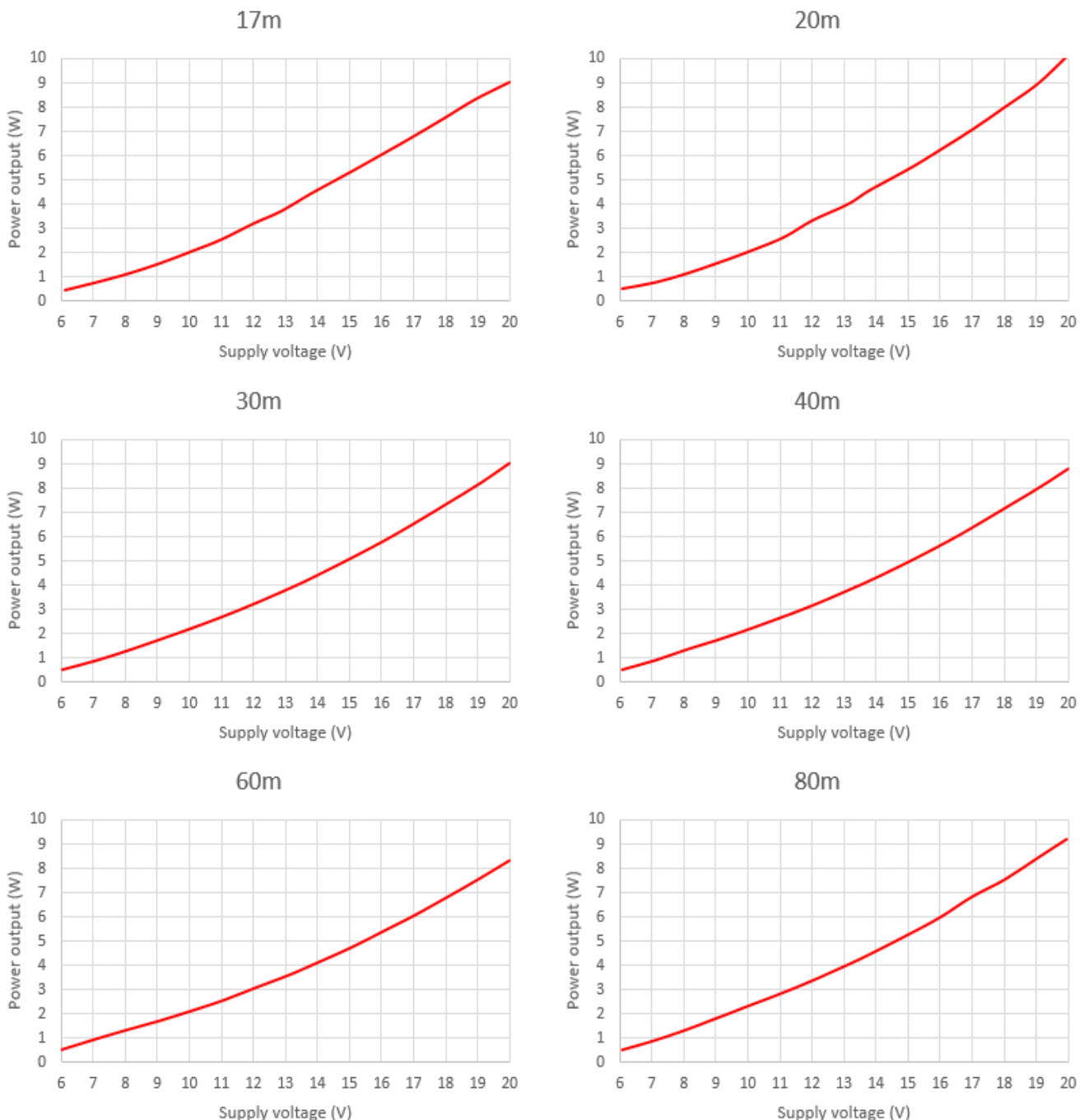

6.4 Class-E Power Amplifier drain waveform

This oscilloscope chart shows the waveform at the BS170 drains (top, RED colour trace) and the input drive waveform, a 5V peak-peak squarewave (bottom, BLUE trace). The 40m band is shown.

Upon ignoring the “ringing” artifacts due to poor ‘scope probes etc., the waveforms are correct for Class-E operation.

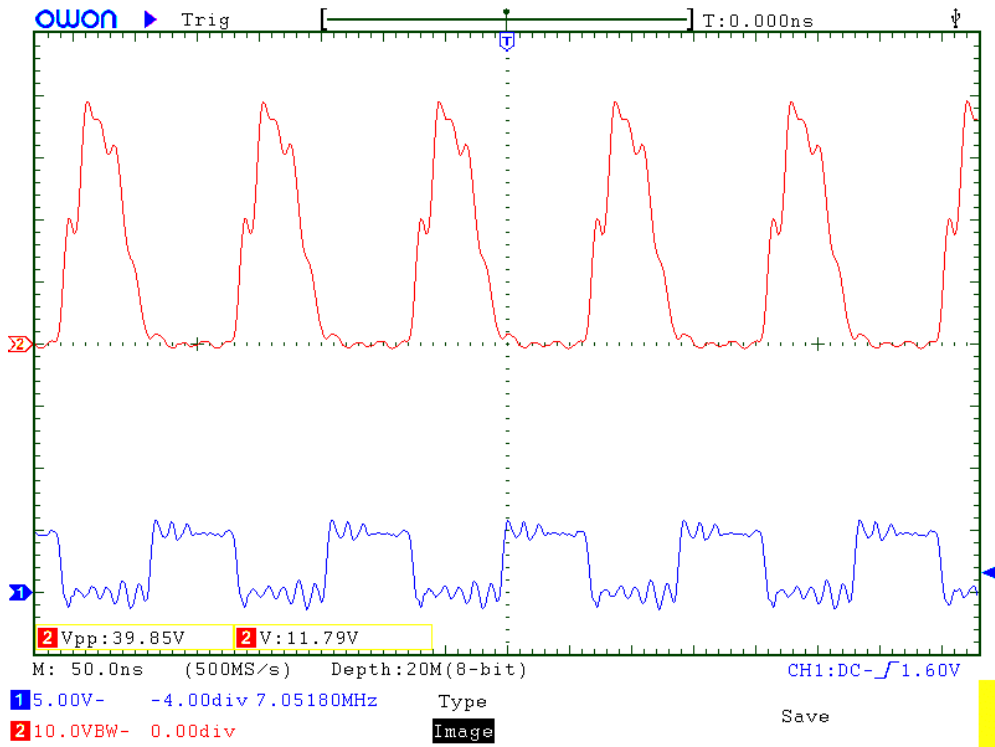

6.5 RF envelope key-shaping

The following oscilloscope images show the RF envelope when keyed with a continuous 24 words per minute (50ms duration) string of dits. The simple key-shaping circuit described earlier results in rise/fall times of around 5ms and significantly attenuates key-clicks.

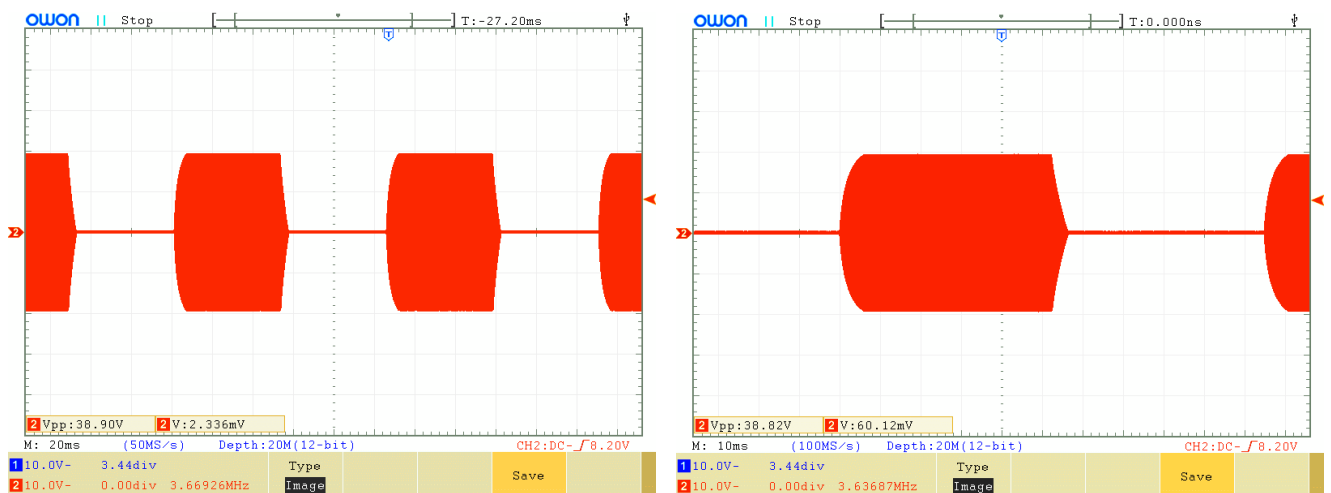

6.6 Low Pass transmitter harmonic output filter characteristics

The Low Pass Filter response was not measured. The Low Pass Filter is the same as the QRP Labs Low Pass Filter kit module <http://qrp-labs.com/lpokit> . Measurements of the Ultimate3S kit <http://qrp-labs.com/ultimate3/u3s> using these filters is on this page <http://www.qrp-labs.com/ultimate3/u3info/u3spec.html>

6.7 Band Pass receiver input filter characteristics

The following charts show measurements of the simple band pass receiver input filter implemented using transformer T1. For each band, one image shows the close-in response, the other shows the response across 0 to 30MHz.

Note that in the circuit, the Band Pass filter sits behind the Low Pass filter. Therefore, the low pass filter response is ADDED to the band pass filter response. These charts show a relatively poor attenuation above the passband – but this is not a problem because in this region the Low Pass Filter provides high attenuation.

For each band, the 3dB bandwidth was measured. The tuning range available was also measured (from having the C1 trimmer capacitor plates fully meshed, to having them fully un-meshed). Also shown is the attenuation at the center frequency.

80m band

3dB bandwidth: 343kHz

Insertion loss: 1.10dB at 3.520MHz center

Tuning range: 3.320MHz to 4.03MHz

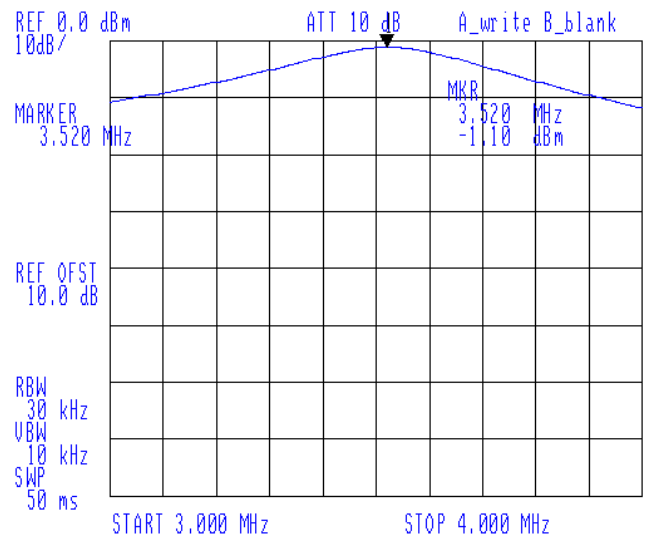
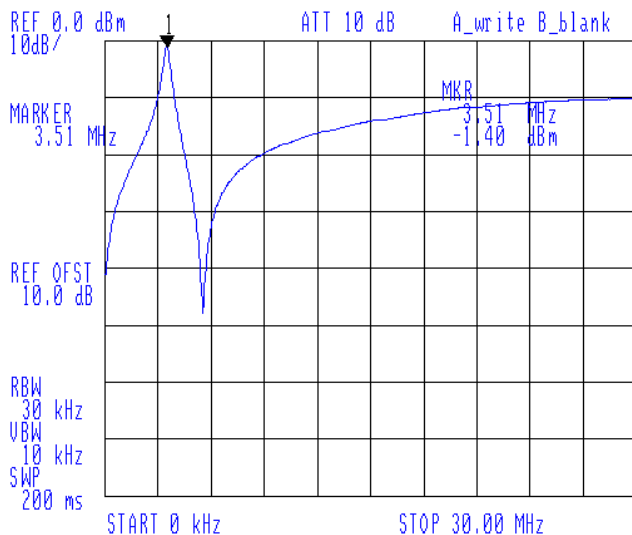

60m band

3dB bandwidth: 367kHz

Insertion loss: 1.45dB at 5.357MHz center

Tuning range: 4.63MHz to 5.91MHz

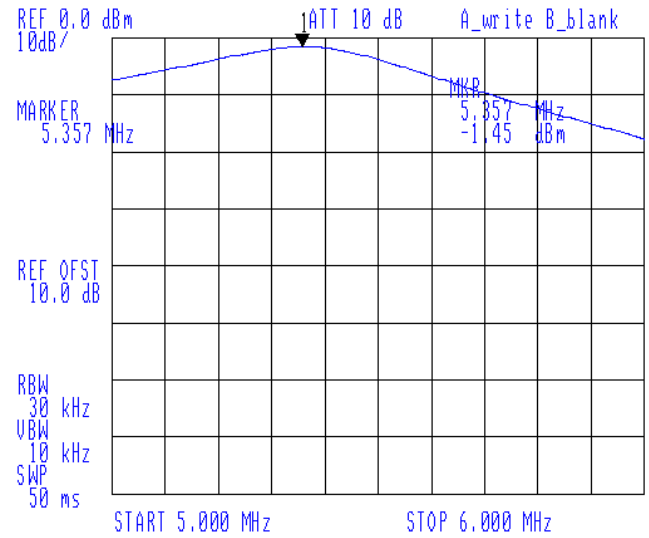
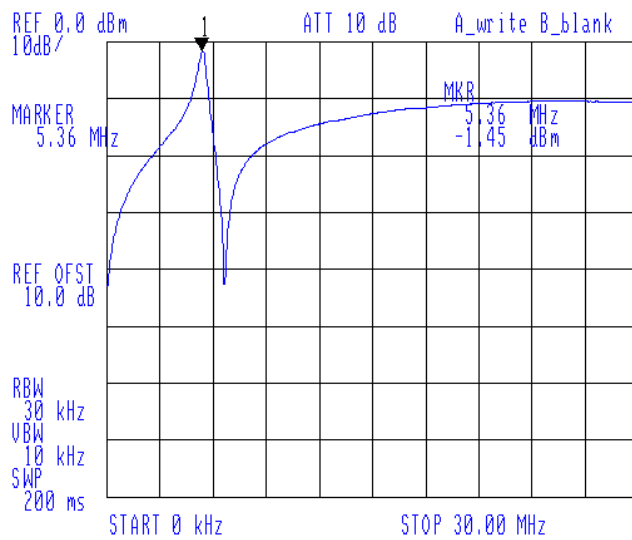

40m band

3dB bandwidth: 514kHz

Insertion loss: 1.97dB at 7.020MHz center

Tuning range: 6.04MHz to 8.36MHz

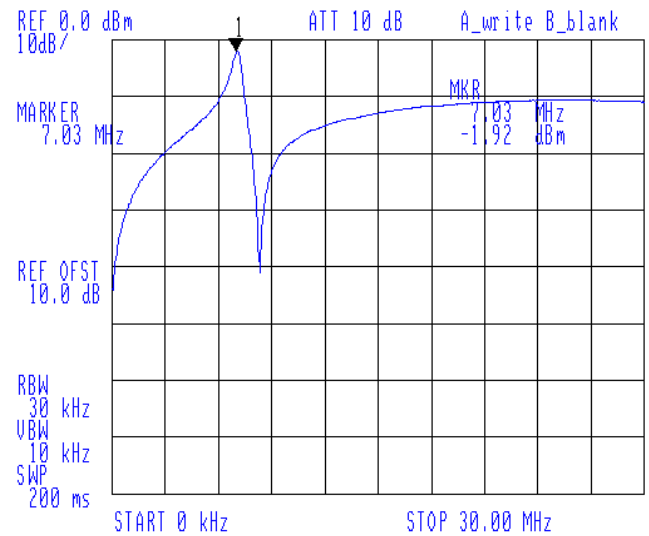
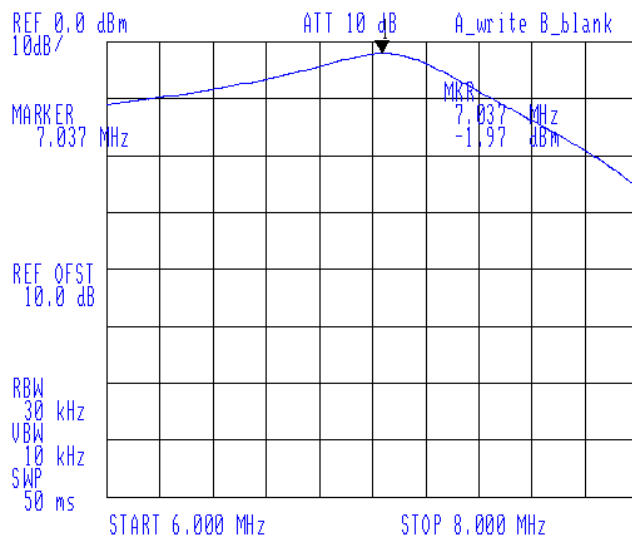

30m band

3dB bandwidth: 645kHz
Insertion loss: 2.67dB at 10.120MHz center
Tuning range: 7.93MHz to 12.47MHz

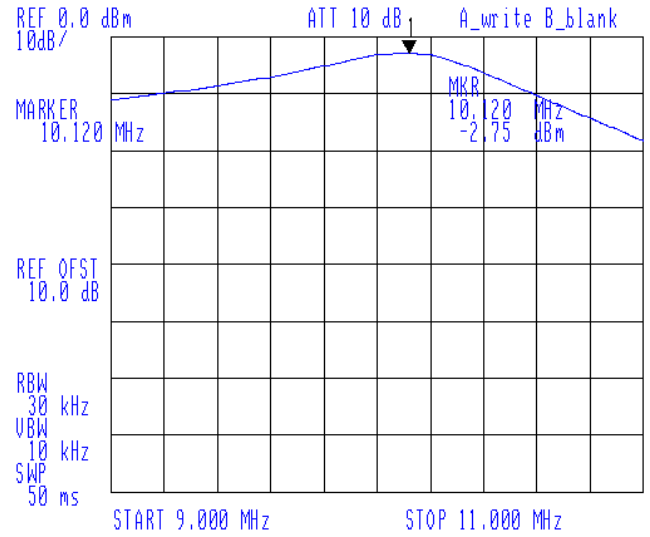
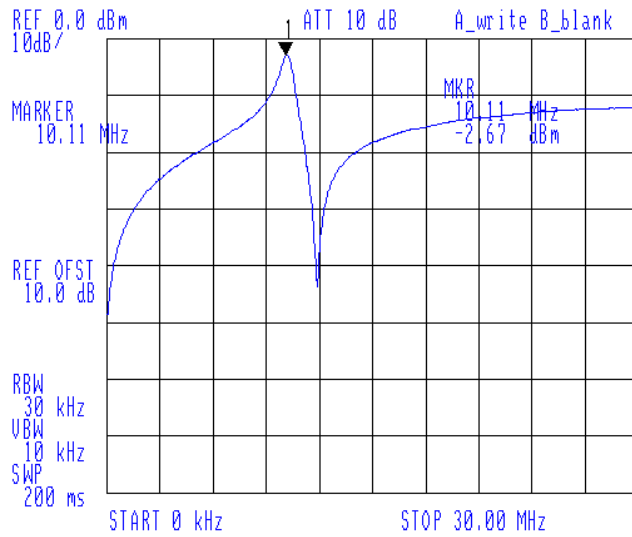

20m band

3dB bandwidth: 1,083kHz
Insertion loss: 1.30dB at 14.020MHz center
Tuning range: 9.69MHz to 22.54MHz

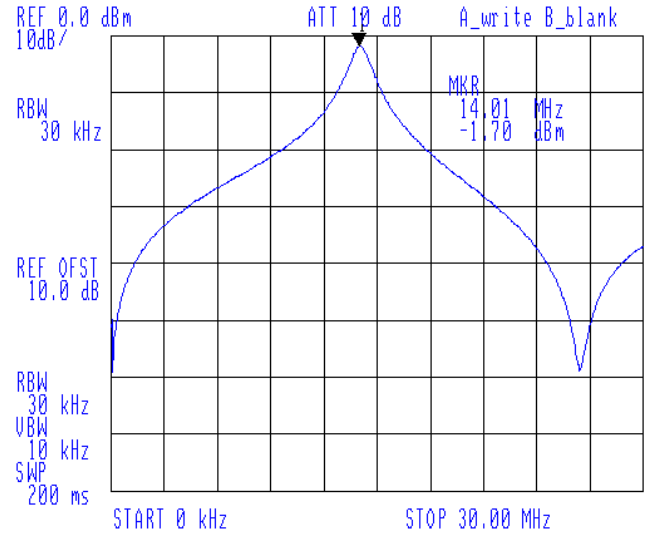
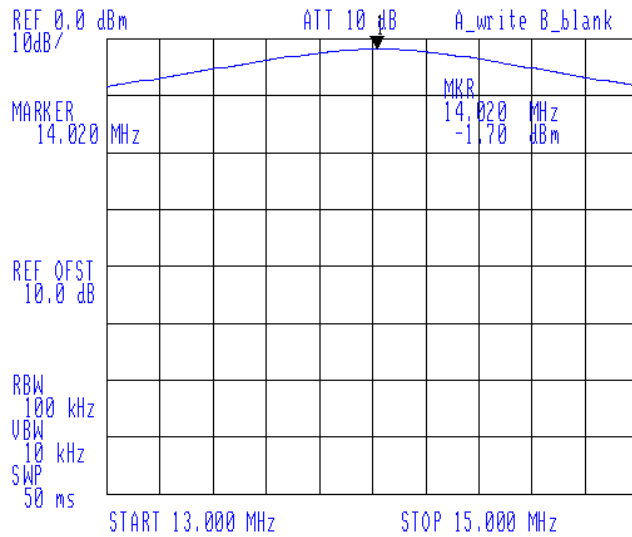

17m band

3dB bandwidth: 1,352kHz

Insertion loss: 2.77dB at 18.120MHz center

Tuning range: 12.64MHz to 35.0MHz

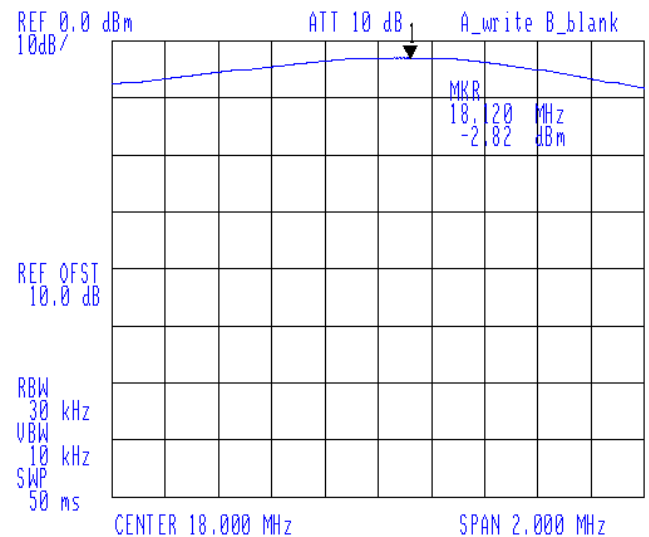
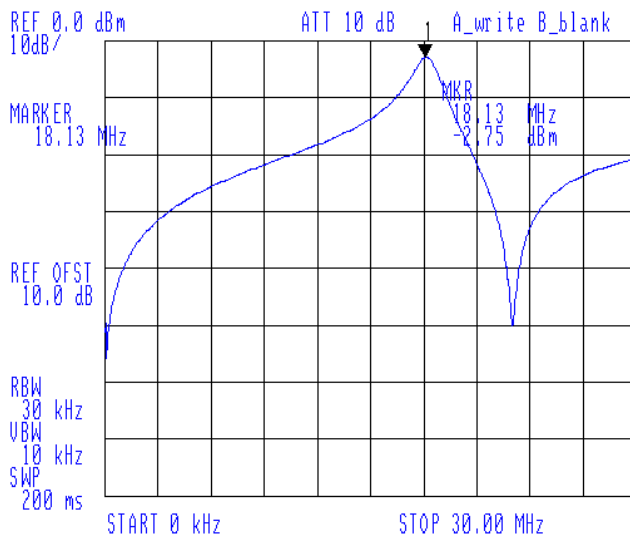

6.8 Quadrature Sampling Detector bandwidth

The following chart shows the attenuation naturally provided by the Quadrature Sampling Detector from -20kHz to +20kHz from the Local Oscillator frequency. The narrow characteristic of this circuit is an advantage because it effectively adds an additional narrow RF bandpass filter to the receiver, preventing strong nearby signals from reaching the audio amplifier stages. This improves intermodulation performance.

The circuit parameters are optimized for CW operation in this transceiver. A constructor wishing to use the I-Q outputs from IC5 to feed a computer SDR, would wish to flatten this response. To do this, reduce the values of the four 470nF capacitors C43 to C46.

QSD bandpass characteristic

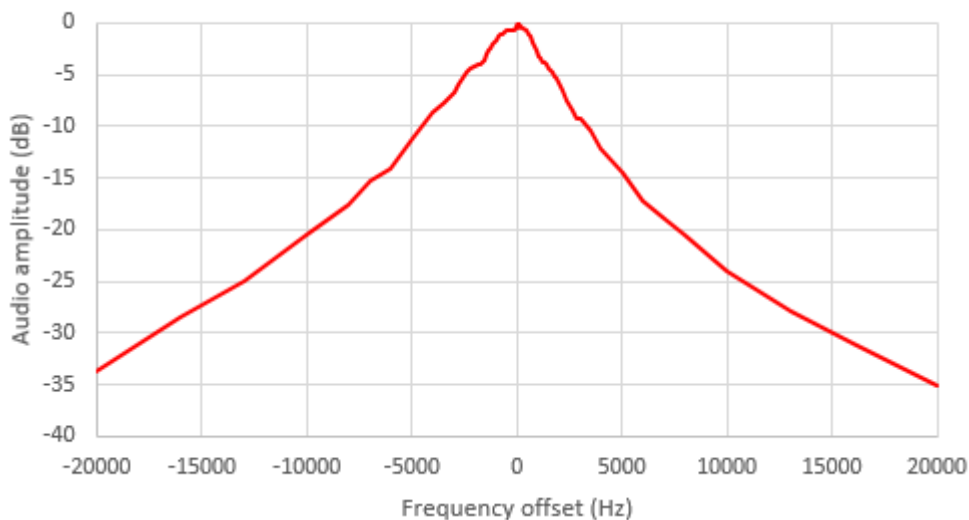

The following chart shows the Quadrature Sampling Detector roll-off over the narrower range 0 to 5kHz. You can see that at the CW operating frequency 700Hz, the attenuation is insignificant; the roll-off of the QSD does not significantly improve the selectivity of the CW filter, but it does improve the intermodulation characteristics of the receiver.

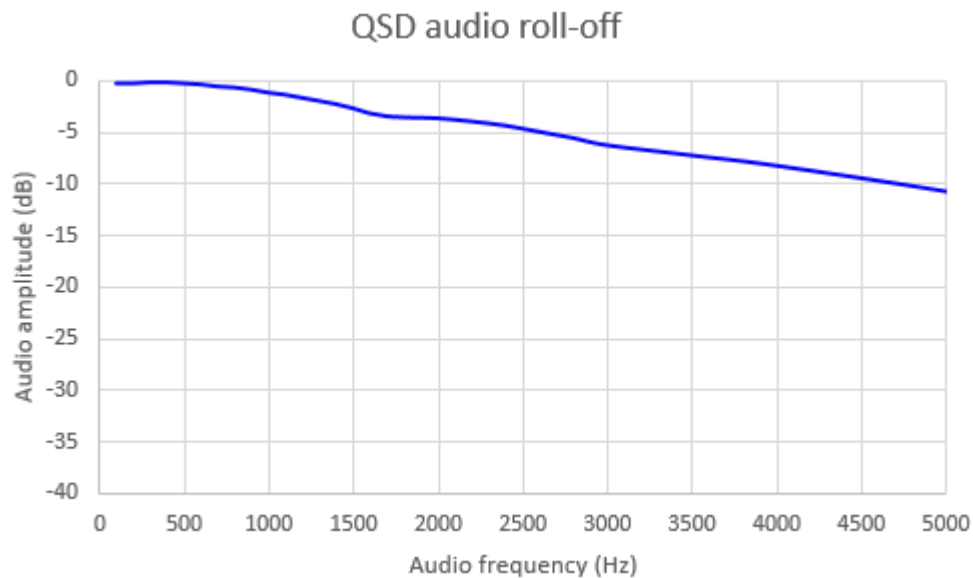

6.9 CW Filter response

This chart shows the measured response of the CW filter (combined with the other filtering in the receiver chain). It was measured by tuning the receiver across a test signal. Note that the center frequency, a little over 700Hz, could be altered by changing some component values.

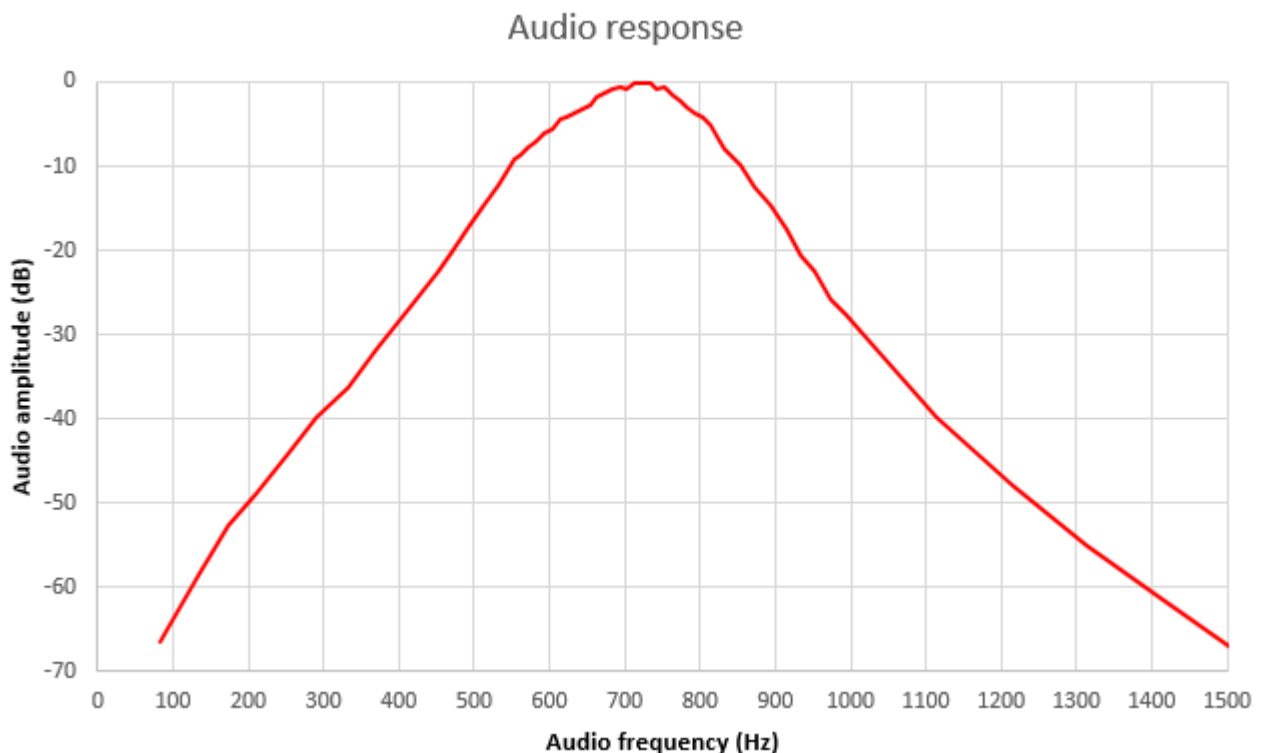

6.10 Unwanted sideband rejection

The following chart shows the measured level of the Upper Sideband signal (USB) and the unwanted Lower Sideband signal (LSB) when tuning the receiver through a strong test signal. The curves depend very heavily on the I-Q balance and audio phase shift adjustments, and these curves are from one measured prototype.

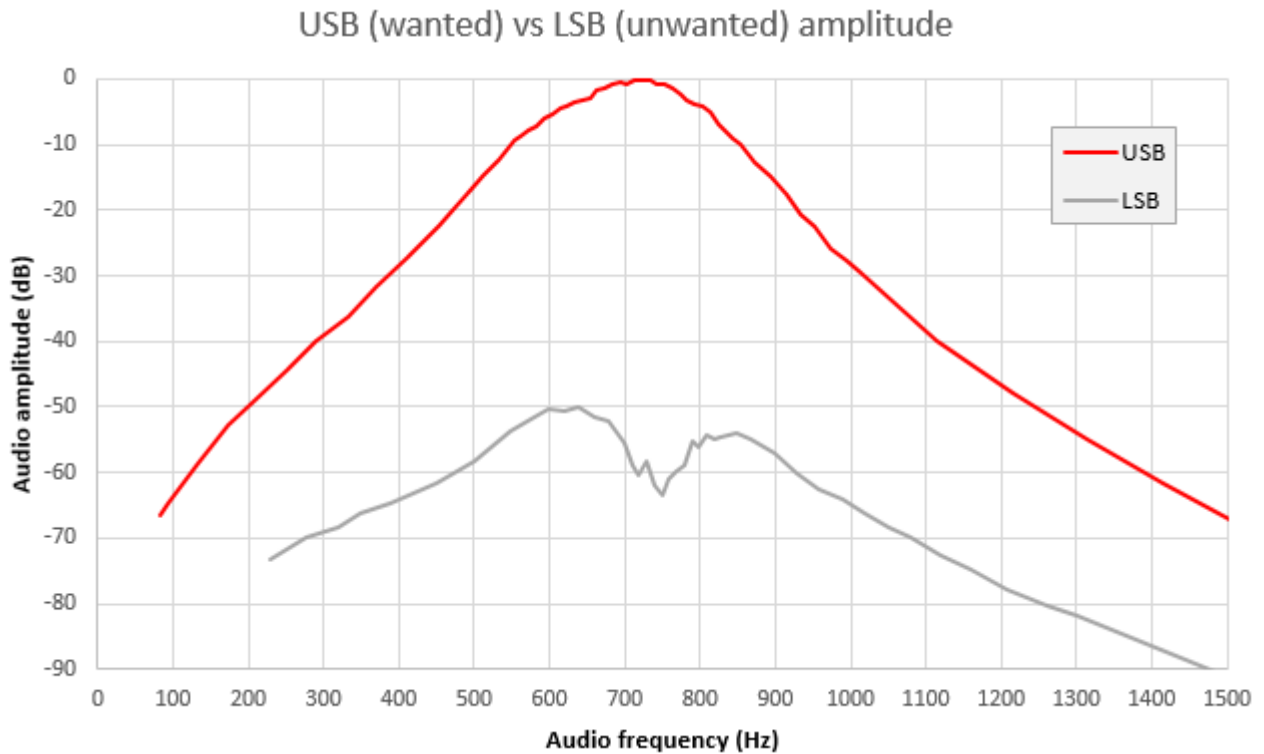

Subtraction of these two curves results in the unwanted sideband level as shown in the following chart. Normally anything above 40dB rejection is considered good; above 50dB is excellent. With the built-in adjustment features of this kit it is relatively easy to achieve really excellent unwanted sideband rejection.

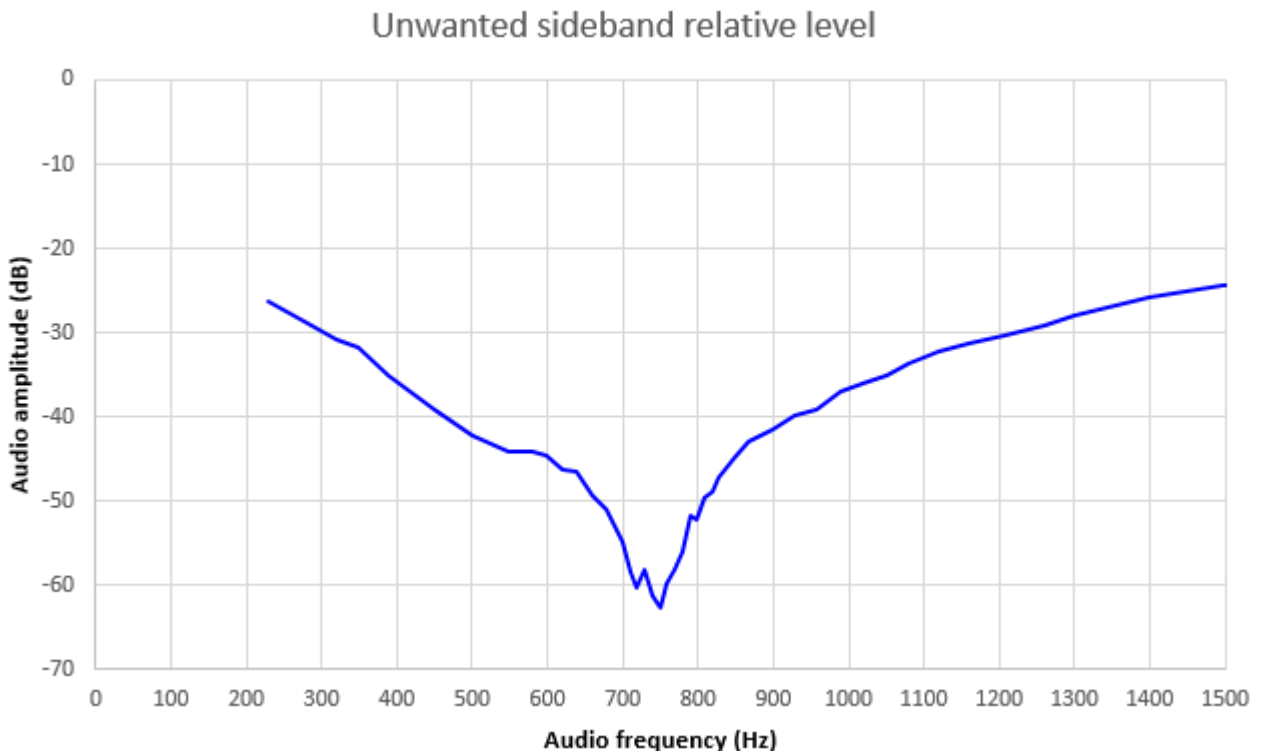

7. Operation reference “cheat sheet”



Main controls functions:

<p>“Select” single press: Keyer speed adjust, then “Select” again to select, or “Exit” to cancel.</p> <p>Double press: RIT adjust, then “Select” again to select, or “Exit” to cancel</p> <p>Long press: Enter the configuration menu (see below)</p>	<p>“Exit” single press: change VFO mode: A, B, Split</p> <p>Double press: Select frequency preset. Then press “Select” (save VFO to preset), “Exit” (load preset to VFO) or “Rotary” (cancel)</p> <p>Long press: swap VFO A and B frequencies</p>	<p>Encoder turn: tuning, menu selection, editing, etc</p> <p>Encoder press: change tune rate 1kHz->500Hz->100Hz->10Hz</p> <p>Encoder dbl or long press: choose stored message. Then “Select” to send repeatedly, “Rotary” to send once, or “Exit” to cancel</p>
--	--	---

Configuration menu items:

1 Preset

Preset 1 to Preset 16: Enter frequency presets.

2 Messages

2.1 Message 1 to Message 12:

Stored messages. First four are 100 characters, rest are 50 characters.

2.13 Interval: gap between message transmissions, in seconds

2.14 Repeats: number of message repeats, 1 to 99 or infinite

3 VFO

3.1 VFO mode: A, B or Split

3.2 VFO A: startup frequency

3.3 VFO B: startup frequency

3.4 Tune rate: startup rate, 1kHz, 500Hz, 100Hz or 10Hz

3.5 RIT: Receive incremental tuning

3.6 RIT rate: 1kHz to 1Hz

3.7 CW-R: Enable CW-R mode

3.8 CW offset: default offset (700Hz)

4 Keyer

4.1 Keyer mode: Straight, Iambic A/B, Ultimatic

4.2 Keyer speed: in words per minute

4.3 Keyer swap: swap paddle inputs

4.4 Keyer weight: alter dit:space ratio

4.5 Auto space: enable keyer autospacing (default OFF)

4.6 Semi QSK: Enable semi QSK

4.7 Practice: enable practice mode, keys but no RF output

4.8 Sidetone frq: normally set to same as CW offset (700Hz)

4.9 Sidetone vol: volume, 0 to 99

4.10 Strght mode: both/dip/ring allows use of 3.5mm mono plug

5 Decoder

5.1 Noise blanker: period in ms

5.2 Speed Avg: for speed detection

5.3 Ampl. Avg: for ampl. detection

5.4 Enable Rx: enable Rx decoder

5.5 Enable Tx: enable Tx decoder

5.6 Enable Edit: enable CW decoding during menu editing (usefull!)

6 Beacon

6.1 Beacon: On/Off enable beacon operation

6.2 Mode: CW or WSPR

6.3 Frequency: beacon frequency

6.4 Frame: frame duration in minutes

6.5 Start: minutes past the hour to start

6.6 WSPR call: Callsign to encode in WSPR message

6.7 WSPR locator 4-character Maidenhead square

6.8 WSPR power dBm power level to encode in WSPR message

6.9 Set time: set real time clock

7 Other

7.1 Dbl click: dbl click delay time in milliseconds (300)

7.2 Battery: enable battery icon on the display top right

7.3 Batt. Full: set millivolts for a “full” battery icon indication

7.4 Batt. set millivolts for each battery bar step level in the icon display

7.5 Cursor blink: Enable blinking cursor

7.6 S-meter: enable S-meter display on the screen

7.7 S-meter step: set value of each S-meter bar (in amplitude units)

7.8 Custom splsh: enable custom splash screen

7.9 Clock : enable real time clock

7.10 Delim.: set thousands delimiter

7.11 Factory rst.: Factory reset, if set to value 17 – use with caution

8 Alignment

8.1 Alignment freq: frequency for BPF alignment

8.2 I-Q balance freq: audio frequency for I-Q balance adjustment (700Hz)

8.3 Phase adj Lo freq: audio freq for low audio phase adj (600Hz)

8.4 Phase adj Hi freq: audio freq for high audio phase adj (800Hz)

8.5 Ref. frq.: 27MHz synth reference frequency used for synthesizer

8.6 System frq.: 20MHz system clock frequency used for system timing

8.7 Peak BPF: do the actual BPF peaking alignment

8.8 I-Q bal.: do the I-Q balance adjustment

8.9 Phase Lo: do low audio phase adjustment

8.10 Phase Hi: do high audio phase adjustment

8.11 Cal ref. osc: do GPS calibration of 27MHz osc if GPS is connected

8.12 Cal sys. osc: do GPS calibration of 20MHz osc if GPS is connected

8.13 GPS data: show GPS satellite data if GPS is connected

9 Test equipment

9.1 Voltage: measure voltage

9.2 RF Power: measure RF power

9.3 Audio Ch.0: measure audio channel 0 amplitude

9.4 Audio Ch.1: measure audio channel 1 amplitude

9.5 Frequency: measure frequency

9.6 Signal gen.: enable and adjust signal generator output

Save settings!: save current VFO etc settings to be the default on power up; press “Select” to save, “Exit” to cancel

8. Resources

- For updates relating to this kit please visit the QRP Labs CW transceiver QCX-mini kit page <http://grp-labs.com/qcxmini>
- For any questions regarding the assembly and operation of this kit please join the QRP Labs group, see <http://grp-labs.com/group> for details

9. Document Revision History

1.00	10-Dec-2020	First version 1.00 for QCX-mini
1.01	11-Dec-2020	Edits in the circuit description and other sections; corrections to many typos
1.02	12-Dec-2020	More minor edits and corrections
1.03	14-Dec-2020	Corrections to parts list, more typos and minor errors fixed
1.04	15-Dec-2020	Add 10uF electrolytic capacitor in parallel with C38
1.05	15-Dec-2020	Add 10uF tantalum section
1.06	29-Oct-2021	Revised for QCX-mini PCB Rev 3
1.07	27-Nov-2021	Added instructions for 160m QCX-mini
1.08	14-Feb-2022	Amended, 160m should now use 27MHz xtal or 25MHz TCXO
1.09	22-Feb-2022	Updated photos at sections 3.12 and 3.19
1.10	06-May-2022	Fix photos 14 and 15 in the T1 winding section
1.11	06-Jun-2022	Updated for 33pF capacitor, and the new longer pin 2x4-pin header.